



Netaji Subhash Engineering college

Techno City, Garia, Kolkata – 700 152

3.3.5 Number of books and chapters in edited volumes / books published, and papers in national/international conference-proceedings per teacher during last five years

A. Books and Chapters in edited volume / books published during the last five years

Sl No.	Name of the Teacher	Title of the book/ chapters published	Title of the paper	ISBN/e-ISBN No.
1	Anupam Ghosh	Advances in Electrical, Electronics, Information, Communication & Bio-Informatics, International Conferences, 2nd 2017 (AEEICB2017),IEEE	Selection of genes mediating human leukemia, using an Artificial Neural Network approach	978-1-5090-5435-0
2	Rajdeep Chakraborty, Runa Seth	Computational Intelligence, Communication, and Business Analytics, Springer	High Entropy and Avalanche Based Non-Feistel Cascaded CFB Block Cipher Through RSBPNDS and TE	978-981-10-6426-5 / 978-981-10-6427-2
3	Chandra Das, Sourav Dutta	Emerging Technologies in Data Mining & Information Security, Springer	SBi-MSREimpute: A Sequential Biclustering Technique based on Mean Squared Residue and Euclidean distance to Predict Missing Values in Microarray Gene Expression Data	978-981-13-1497-1 / 978-981-13-1498-8
4	Anupam Ghosh	Advances In Computing, Communication and Informatics, International Conference, 2016 (ICACCI 2016)(4 VOLS) IEEE	An Improved Fuzzy Based Approach To Impute Missing Values In DNA Microarray Gene Expression Data With Collaborative Filtering	978-1-5090-2030-0
5	Anupam Ghosh	Research In Computational Intelligence and Communication Networks, International Conference, 2 nd 2016, (ICRICN 2016) (CDROM), Springer	An Ensemble Based Missing Value Estimation In DNA Microarray Using Artificial Neural Network	978-981-10-4602-5 / 978-981-10-4603-2

Shilpi Bose.



08/02/2019

PROF. (DR.) TIRTHANKAR DATTA
Principal
Netaji Subhash Engineering College
Techno City Garia,
Kolkata - 700 152

6	Anupam Ghosh	Advanced Computing & Communication Technology- Proceeding of the 10 th ICACCT, 2016, Springer	Gene Ontology Based Function Prediction of Human Protein Using Protein Sequence and Neighborhood Property of PPI Network	978-981-10-4602-5 / 978-981-10-4603-2
7	Piyali Chatterjee	Proceeding of the 5 th International Conference on Frontiers in Intelligent Computing: Theory & Applications, FICTA 2016, Vol-2, Springer	Gene Ontology Based Function Prediction of Human Protein Using Protein Sequence and Neighborhood Property of PPI Network	978-981-10-3155-6 / 978-981-10-3156-4
8	Piyali Chatterjee	Advanced Computing & Systems for Security, Vol-4, Spinger	Functional Group Prediction of Un-annotated Protein by Exploiting Its Neighborhood Analysis in Saccharomyces Cerevisiae Protein Interaction Network	978-981-10-3390-2 / 978-981-10-3391-9
9	Piyali Chatterjee	Proceeding of the 5 th International Conference on Frontiers in Intelligent Computing: Theory & Applications, FICTA 2016, Vol-2, Springer	PLoc-Euk: An ensemble classifier for prediction of Eukaryotic Protein Subcellular Localization	978-981-10-3155-6 / 978-981-10-3156-4

B. Papers in national / international conference proceedings during the last five years

Sl No.	Name of the Teacher	Title of the paper
1	Chandra Das & Shilpi Bose	NHGSSC: New Hybrid Gene Selection-Sample Classification Method in Microarray Data
2	Chandra Das & Shilpi Bose	An Ensemble Filtering Approach based Supervised Gene Clustering Algorithm to Identify Informative Genes to Improve Sample Classification Accuracy in Microarray Gene Expression Data
3	Atanu Das	A New Method for Tutorial Gap Identification towards Students Modeling
4	Rajdeep Chakraborty, Runa Seth	Design of FPGA Based ECB Cryptosystem: RPPT Embedded with TB
5	Rajdeep Chakraborty, Runa Seth	An FPGA Based Block Cipher through Recursive Positional Substitution on Prime-Nonprime of Cluster (RPSPNC)

Shilpi Bose.



2

08/02/2015
 PROF. (DR.) TIRTHANKAR DATTA
 Principal
 Netaji Subhash Engineering College
 Techno City Garia,
 Kolkata - 700 152

CURRAN ASSOCIATES INC.

proceedings.com

Conference Proceedings Specialists

HOME | ABOUT US | CONTACT | FAQ | [VIEW CART](#)

Cart 0 Item(s) \$0.00
Call Toll-Free (USA)
866-964-0401

[Search](#)
[Partners](#)
[News](#)
[General Info](#)

Browse by Publisher

Browse by Category

- [Aerospace](#)
- [Agriculture](#)
- [Biology - Medicine](#)
- [Chemical - Petroleum](#)
- [Civil](#)
- [Electrical - Computer](#)
- [Environmental](#)
- [Geoscience - Mining](#)
- [Materials Science](#)
- [Mechanical](#)
- [Nanotechnology](#)
- [Physics - Nuclear - Math](#)
- [Other](#)





Home > Browse by Publisher > Institute of Electrical and Electronics Engineers (IEEE) > ADVANCES IN ELECTRICAL, ELECTRONICS, INFORMATION, COMMUNICATION AND BIO-INFORMATIC S. INTERNATIONAL CONFERENCE. 3RD 2017. (AEEICB 2017)



ADVANCES IN ELECTRICAL, ELECTRONICS, INFORMATION, COMMUNICATION AND BIO-INFORMATIC S. INTERNATIONAL CONFERENCE. 3RD 2017. (AEEICB 2017)

Item #: 35129

Our Price: \$276.00

Pricing: Non-Member \$276.00

IEEE Member #:



Product Description

Title:	2017 Third International Conference on Advances in Electrical, Electronics, Information, Communication and Bio-Informatics (AEEICB 2017)
Desc:	Proceedings of a meeting held 27-28 February 2017, Chennai, India.
Prod#:	CFP17E54-POD
ISBN:	9781509054350
Pages:	552 (1 Vol)
Format:	Softcover
Notes:	Authorized distributor of all IEEE proceedings
TOC:	View Table of Contents
Publ:	Institute of Electrical and Electronics Engineers (IEEE)
POD Publ:	Curran Associates, Inc. (Aug 2017)

Related Products



COMMUNICATIONS. IEEE INTERNATIONAL CONFERENCE. 2006. (12 VOL S)



DESIGN AUTOMATION AND TEST IN EUROPE. CONFERENCE. 2006. (3 VOL S)



WIRELESS AND OPTICAL COMMUNICATIONS NETWORKS. IFIP INTERNATIONAL CONFERENCE. 2006. (2 VOL S)

2017 Third International Conference on Advances in Electrical, Electronics, Information, Communication and Bio-Informatics (AEEICB 2017)

**Chennai, India
27-28 February 2017**



**IEEE Catalog Number: CFP17E54-POD
ISBN: 978-1-5090-5435-0**

**Copyright © 2017 by the Institute of Electrical and Electronics Engineers, Inc
All Rights Reserved**

Copyright and Reprint Permissions: Abstracting is permitted with credit to the source. Libraries are permitted to photocopy beyond the limit of U.S. copyright law for private use of patrons those articles in this volume that carry a code at the bottom of the first page, provided the per-copy fee indicated in the code is paid through Copyright Clearance Center, 222 Rosewood Drive, Danvers, MA 01923.

For other copying, reprint or republication permission, write to IEEE Copyrights Manager, IEEE Service Center, 445 Hoes Lane, Piscataway, NJ 08854. All rights reserved.

****** This is a print representation of what appears in the IEEE Digital Library. Some format issues inherent in the e-media version may also appear in this print version.***

IEEE Catalog Number:	CFP17E54-POD
ISBN (Print-On-Demand):	978-1-5090-5435-0
ISBN (Online):	978-1-5090-5434-3

Additional Copies of This Publication Are Available From:

Curran Associates, Inc
57 Morehouse Lane
Red Hook, NY 12571 USA
Phone: (845) 758-0400
Fax: (845) 758-2633
E-mail: curran@proceedings.com
Web: www.proceedings.com

CURRAN ASSOCIATES INC.
proceedings
.com

Table of Contents

Comparative Analysis and Optimal Wavelet Selection of Partial Discharge De-noising Methods in Gas-Insulated Substation.....	1
<i>Raghavendra Bandaru and Krishna Chaitanya Mallula</i>	
An Improved Initial Radius Selection Scheme For Sphere Decoding In MIMO.....	6
<i>Jianping Li and Zhenguo Wang</i>	
Design and Implementation of Smart Home Control using LabVIEW.....	10
<i>Prashant Kumar</i>	
Summary for Resonance Suppression Technology of Renewable energy Power Generation .	13
<i>Ruiming Wang, Shiyi Liu, Qihui Liu and Yiming Yu</i>	
Design of 4 Bit 4 Pulse Finite State Machine Serial Adder.....	18
<i>Divyesh Divakar, Floyd James, Akshatha Mallya, Srigowri Hebbar and Anjali Shetty</i>	
Investigation on UWB Kite shape Textile antenna with Defective Ground Structure.....	21
<i>Ramesh Manikonda</i>	
A Perceptive Based Application along with High Frequency Direction Finder during Quagmire in our Provincial.....	25
<i>Arunprasad Kannuchamy, Pushpavalli Kathirvelu and Keerthana Govindaraj</i>	
Ultra fast acting electronic circuit breaker for overload protection.....	29
<i>Tushar Deokar, Onkar Salunkhe, Ganesh Ankalgi and Vishal Kare</i>	
Nanotechnology Enabled Hybrid Power System Suitable for batteries in Hybrid Electric vehicle.	33
<i>Vaibhav Deshpande and Mohit Talele</i>	
Plausible Characteristics of Association Rule Mining Algorithms for E-Commerce.....	36
<i>Hemant Kumar Soni</i>	
Graphene Photovoltaic Panel (GPP).....	40
<i>Pravin Phutane, Priyanka Pathak, Dhanashree Gaikwad, Aishwarya Inamke and Anil Bodhe</i>	
Performance of 125 Watt PV Module Using MATLAB-Simulink.....	45
<i>Umesh Pagrut, A. S. Sindekar, Sagar Lachure and Jaykumar Lachure</i>	
Design of Simple DC-to-DC Wireless Power Transfer using Inductive Coupling.....	50
<i>Chandrasekharan Nataraj, Dr Sathish Kumar Selvaperumal, Dr Sheraz Khan and Fajingbesi Fawwaz Eniola</i>	
Comparison of Different Types of Raschig Rings.....	56
<i>Shreya Salvi and A.P. Paranjape</i>	
Active Learning Framework of Informative p53 Cancer Rescue Mutants.....	61
<i>Haijin Wang, Ruhui Shen, Haichao Wang, Haohan Wang and Qing Song</i>	
Four-bit full adder-subtractor based on DNA strand displacement.....	67
<i>Dongqing Hu, Bin Wang, Changjun Zhou and Qiang Zhang</i>	

Nano Particle Based Drug Delivery Systems.....	75
<i>Ashline George and Jerin Cyriac</i>	
CURSOR MASQUERADE : Masking of authentic cursor using random numeric keypad and spurious cursors.....	80
<i>Sugumar Vidhya and Soundararajan Porseelvi</i>	
A Combined approach of Steganography with LSB Encoding technique and DES Algorithm.....	85
<i>Karthikeyan B, Deepak A, Subalakshmi K.S, Anishin Raj M M and Vaithyanathan V</i>	
Modified phase-shifted PWM for cascaded H-Bridge Multilevel Inverter	89
<i>Kirthika Devi and Srivani Sg</i>	
Constructing Test Cases Using Natural Language Processing.....	95
<i>Sadaf Fatima Ansari, Shagufta Mirza Baig, Tehreem Shaikh and Ahlam Ansari</i>	
A Novel Pattern Classifier Approach towards the Performance Optimization of Big Data Analysis in Distributed Environment	100
<i>Sandeep Hegde and Dr. Srinivasa Kg</i>	
Implementation Of MPPT With CUK Converter	105
<i>Bandan Kumar Panigrahi and Dr P R Thakura</i>	
Advanced Seven Level Transformer-Less Multilevel Inverter Topology for PV Application .	111
<i>Rajanand Patnaik Narasipuram, Ravindranath Tagore Y and Chaitanya s</i>	
Controlled Islanding Scheme for Power System Protection: Guidelines and Approach (Case Study: Proposed Bhopal Islanding Scheme)	117
<i>Sandeep Ushkewar, Suraj Chaube, Nikhil Komawar, M.Salman Ansari and Nirbhay Tirpude</i>	
Aspect Based Feature Extraction and Sentiment Classification of Review Data sets using Incremental Machine learning Algorithm	122
<i>Rajalaxmi Hegde and Seema S</i>	
Coupled inductor based Single-Input Multiple-Outputs Boost Converter	126
<i>Niharika Deshpande, R. D. Chavhan and Nalinita Deshpande</i>	
Efficient clustering algorithm of minimum Spanning Tree	131
<i>Praveen Pappula, Rama B and Sampath Kumar Tallapally</i>	
A Novel Framework for Stock Trading Analysis Using Casual Relationship Mining	136
<i>Harchana Bhoopathi and Rama B</i>	
Comparison of PV based Embedded Z-Source Inverter fed Three Phase Induction Motor with PI Controller and PID Controller based closed loop systems.....	142
<i>Ramalingam Malathi and Marimuthu Rathinakumar</i>	
Application and performance comparison of variants of the firefly algorithm to the economic load dispatch problem.....	147
<i>Fatma Moustafa, Ahmed El-Rafei, Niveen Badra and Almoataz Abdelaziz</i>	
Analysis of multi-threading time metric on single and multi-core CPUs with Matrix multiplication.....	152
<i>Rinku Ravikanth Dhruva and Dr.Asharani M.</i>	

Development of a Multi Agent System for Voltage and Outage Monitoring	156
<i>Pasan Gunawardena, Geeth Bodhinayake and Udayanga Hemapala</i>	
A Review Of Feature Sub Set Selection On Unsupervised Learning	163
<i>Ravi Kumar R, Babu Reddy M, Praveen P and Rama B</i>	
Cognitive Radio: Energy Detection using Wavelet Packet Transform for Spectrum Sensing	168
<i>Ravi Verma and Arunanshu Mahapatro</i>	
Dynamic Performance Comparison of Quadratic Buck converter with Analog and Digital Average Current-Mode Controllers	173
<i>Ravindranath Tagore Yadlapalli and Anuradha Kotapati</i>	
Performance of Shunt Active Power Filter Controlled by Constant Power Control Technique.....	178
<i>Dhaval Patel, Swati Purohit, Khoda Odedra and Ankitkumar Patel</i>	
A SSSC Based Damping controller for Stability enhancement of power system	183
<i>Ankit Patel, Pranav Raval and Dhaval Patel</i>	
A predictive approach for improving the sales of products in E-commerce.	188
<i>Dr.Ziaul Ain Usmani, Shraddha Manchekar, Tahreem Malim and Ayman Mir</i>	
Solar Photovoltaic Array Based Multilevel Inverter for Power Conditioning In Four-Wire Distribution System.....	193
<i>Mriganka Ghosh Majumder, Prabir Ranjan Kasari, Bikram Das and Abanishwar Chakraborti</i>	
Designing Prototype For Accessing Veracity Using Social Sensors – Big Data Perspective .	198
<i>Karthika S and Parvathi A. V</i>	
Inferring Phylogenies From Minimal Information	202
<i>Ruzbeh Tusserkani, Changiz Eslahchi, Azin Azadi and Hadi Poormohammadi</i>	
Design Of Highly Directional CPW-Fed UWB Antenna.....	207
<i>M Noorjahan, Sheik Dawood and Siva Sivaram.S</i>	
Selection of Gene Mediating Human Leukemia, using An Artificial Neural Network Approach.....	210
<i>Sougata Sheet, Anupam Ghosh and Sudhindu Bikash Mandal</i>	
A Fuzzy Logic based Battery SOC Level Control Strategy for Smart Micro Grid.....	215
<i>Udayanga Hemapala, Dilum Hettiarachchi, Heshan Hasaranga, R.D.T.M. Hemarathne, M.D.C.P.K. Mahawithana and M.G.A.B.N Sandanuwana</i>	
Performance Analysis of Three Leg DSTATCOM Under Distributed Generation and Fault Scenario	222
<i>Sanath Saralaya and Manjunatha Sharma K</i>	
Design & Development of Fuel Cell Oxygen Tree (FCOT)	227
<i>Afzal Ahmed Khan and Dr. Rahul Dahatonde</i>	
Techno Economic Analysis, Design And Implementation of a Suitable Communication Method For Remote Meter Reading using Zigbee	231
<i>Mahesh Dunuweera, Gayashan Dasun, Udayanga Hemapala and Narendra De Silva</i>	

5-Level Cascaded Inverter Based D-STATCOM with LPF-BPF Fundamental Active Current Extractor.....	237
<i>Maharshi Gohil and Amit Sant</i>	
A Survey Of Smart Environment Conservation And Protection For Waste Management...	242
<i>Ramya E and Sasikumar R</i>	
Developing fish feeder using Raspberry Pi	246
<i>Hidayatul Nur Binti Hasim, Mritha Ramalingam, Puviarasi R and Ferda Ernawan</i>	
PLL less Strategy for Grid Tied Inverter with Different Load Conditions	251
<i>Priyanka Patel, Grishma Patel and Unnati Mali</i>	
Investigation of Credit Card Fraud recognition Techniques based on KNN	255
<i>Malini N</i>	
Electronic Sports Gloves	259
<i>Chinmay Itagi and Pritam Gholap</i>	
Wireless Power Transfer System Using Antennas	264
<i>Croydyn Berly, Prateek Kukreja and Dr .Usha Kiran</i>	
A Passing Vehicle Search Algorithm for Solution of Optimal Power Flow Problems	268
<i>Dilip P. Ladumor, R.H. Bhesdadiya, Indrajit N. Trivedi and Pradeep Jangir</i>	
Dual band RF Energy Harvester for Wearable Electronic Technology	274
<i>Naresh Bangari, Vinod Kumar Sing Yadav and Vanga Bhargavi</i>	
A Grey Wolf Optimizer Algorithm for Voltage Stability Enhancement	278
<i>Dilip P. Ladumor, R.H. Bhesdadiya, Indrajit N. Trivedi and Pradeep Jangir</i>	
Optimal Power Flow Problems Solution with SVC using Meta-heuristic Algorithm	283
<i>Dilip P. Ladumor, R.H. Bhesdadiya, Indrajit N. Trivedi and Pradeep Jangir</i>	
Microcontroller based DC-DC Cascode Buck-Boost Converter	289
<i>Sanjeet Kumar and Dr. Parsuram Thakura</i>	
Implementation of Fast Trigger Generator for High Coulomb Spark Gap Switching	295
<i>Renuka Kurhade, Archana Sharma, P. C. Saroj and Dr . Sangeeta Daingade</i>	
An Approach Towards Effective Power Oscillation Damping with Deployment and Tuning of AVR,and PSS	299
<i>Alok Singh</i>	
Analysis and Modelling of Thermal Plant Pollution Performance in H.T Ceramic Post Insulator with Epoxy Resin Coatings	306
<i>Asokan Sivan and Ravindran Mariappan</i>	
Enhancing the Properties of Used Mineral Oil by Regeneration Process	311
<i>Thanga Rathna M, Maheswari R V and Samuel Pakianathan P</i>	
Synthesis of Heuristic Control Strategies for Liquid Level Control in Spherical Tank	316
<i>Deepa P and Rajendran Sivakumar</i>	
A Statistical Study On The AC Breakdown Voltage Of Corn Oil And Mineral Oil For Liquid Insulation.....	320
<i>Narayani A, Willjuice Iruthayarajan M and Bakrutheen M</i>	

Enhancement of Protective Layer Coated Bushing under Artificial Coastal pollution Conditions	324
<i>Sabitha Selva Jothi K and Kalaivani L</i>	
Effects of Demand Side Management & Storage on Renewable Energy Penetration to the Grid	329
<i>Ravishankar A N, Dr. Ashok S and Dr. Kumaravel S</i>	
Designing Software Reuse Repository Through Intelligent Classification for Effective Search and Retrieval Mechanism	336
<i>Rajani Devi and Rama B</i>	
Big Data Transfers Through Dynamic And Load Balanced Flow On Cloud Networks	342
<i>C Jayashri, P Abitha, S Subburaj, S Yamuna Devi, S Suthir and S Janakiraman</i>	
Matching of Video Frames Through Coupled Decomposition	347
<i>Viji Charles and Dr. Sudhir Sawarkar</i>	
Neural Network based Cycloconverter Fault Detection using Wavelet Decomposition	352
<i>Dibyendu Khan and Sankhadip Saha</i>	
Comparative Study on Various Single Image Defogging Techniques	357
<i>Jaswinder Kaur and Prabhpreet Kaur</i>	
ANN Based Ranking Algorithm for Products on E-Commerce Website	362
<i>Aditya Parashar and Eshan Gupta</i>	
Design and Analysis of U-Shaped Microstrip Patch Antenna	367
<i>Kanna Dhasan and A.C.Shagar Dr</i>	
PAPR Reduction in OFDM Using Reduced Complexity PTS with Companding	371
<i>Sravanti Thota and Vasantha N</i>	
A Leading Zero(es) Count Algorithm	375
<i>S. Subha</i>	
Efficient Decision Support System For Agricultural Applications	379
<i>R Devi Ravichandaran and Hemalatha R</i>	
Risk prediction of type II diabetes based on random forest model	382
<i>Weifeng Xu, Jianxin Zhang, Qiang Zhang and Xiaopeng Wei</i>	
Optimal Power Flow with Shunt Flexible AC Transmission System (FACTS) Device Using Grey Wolf Optimizer	387
<i>Ladumor Dilip, Bhesdadiya Rajnikant, Indrajit Nandlal Trivedi and Pradeep Jangir</i>	
Optimal Power Flow Problems Solution with STATCOM using Meta-heuristic Algorithm	392
<i>Ladumor Dilip, Rajnikant Bhesdadiya, Indrajit Trivedi and Pradeep Jangir</i>	
Certificate-free Collaborative Key Agreement based on IKEv2 for IoT	397
<i>Lavanya Murugan and Natarajan V</i>	
A multipath mechanism for wireless sensors network	401
<i>Haijin Wang, Qi Li, Yang Yang and Quanming Wang</i>	

Harmonic Current Compensation Improvement at Point of Common Coupling Using Hybrid Natural Green Sources	406
<i>Nagaraj C and Dr.K.Manjunatha Sharma</i>	
Automatic Interpretation Of Analog Dials In Driver's Instrumentation Panel	411
<i>Selvathai T, Jayaa Shalinni S, Swarna Ramesh and Radhakrishnan K K</i>	
A Hybrid Technique to Reduce PAPR in OFDM Systems	416
<i>Sravanti Thota and Vasantha N</i>	
An efficient approach for the Detection of White Matter(WM), Gray Matter(GM), and Cerebrospinal Fluid(CSF) from MR images of the brain using an advanced Multilevel Thresholding.....	422
<i>Sandhya Gudise, Giribabu Kande and Satya Savithri T</i>	
Efficient Routing Protocols for Mobile Ad Hoc Network	427
<i>Thiagu Raj and Dr Madhavan Moorthi</i>	
A Novel Seven Level Symmetrical Multilevel Inverter Topology	432
<i>Chaitanya S, Rajanand Patnaik Narasipuram and Murthy Dr. K. V. S.R.</i>	
A review on design approach for performance enhancement techniques of microstrip patch antenna.....	436
<i>Tushar Agale and Milind Khanapurkar</i>	
Pattern recognition based fault classification for teed transmission line	441
<i>Dipak Parmar and Bhargav Vyas</i>	
Security Challenges in IoT	446
<i>Aditya Parashar and Sachin Rishishwar</i>	
Modified integration method to estimate stator flux in induction motor with offset error. .	450
<i>Abhinav Khandekar and Jagdish Chaudhari</i>	
Green Initiatives in IoT	454
<i>Sudhir Routray and Sharmila K.P</i>	
Routing in Dynamically Changing Node Location Scenarios: A Reinforcement Learning Approach	458
<i>Sudhir Routray and Sharmila K.P</i>	
Optimization of Energy Exhaustion for Smart Camera Network in Vision Task	463
<i>Gudapati Ramyasri and Sharma Sarvanan</i>	
High fitness population (HFP) with GA solution for solving unit commitment of large system	468
<i>Avishkar Rajawat, M.P. Sharma and Manoj Kumar</i>	
Review on 4G Antenna for LTE Application.....	476
<i>Rubesh Kumar and Dr.Madhavan. Moorthi</i>	
Wavelet Packets for Speech Emotion Recognition.....	479
<i>Firoz Shah and Babu Anto Puthur</i>	
M Energy Audit Reports.....	482
<i>R Saravanakumar</i>	

Performance Analysis Of Standalone Photovoltaic System	486
<i>Karthikeyan .V</i>	
Technology options for DSM in interior lighting	491
<i>Shailesh K R</i>	
VHDL Based BLOWFISH Implementation for Secured Embedded System Design	497
<i>Irfan Landge and Dr. B.K. Mishra</i>	
Enhancing an elevator efficiency by using supercapacitor	502
<i>Priyanka Kubade and Shradha Umathe</i>	
Comparison of Ultra-capacitor and Hybrid Ultra-capacitor	506
<i>Pratik Dhabe and Shrikrishna Tarnekar</i>	
Opportunistic Task Offloading in Vehicular Networks	510
<i>Mohammad Pasha and Khaleel Ur Rahman Khan</i>	
Improving The Dynamic Performance Of Three Phase Induction Motor By Using Ultra Capacitor	515
<i>Roopali Edke and Ramchandra Adware</i>	
IoT based Smart Museum using Bluetooth Low Energy	520
<i>Sornalatha K and Kavitha V R</i>	
An Effective Hybrid Cuckoo Search with Harmony Search for Review Spam Detection . . .	524
<i>Rajamohana Sp, Umamaheswari K and Vasantha Keerthana S</i>	
Data Security Using Data Compression in MANETs	528
<i>Vimala Shanmugam</i>	
Balancing and Control of Dual Wheel Swarm Robots by Using Sensors and Port forwarding Router	532
<i>G. Chinnadurai and Dr.H Ranganathan</i>	
GAMES-Glaucoma Analysis and Management using an Expert System	537
<i>Jayashree Agarkhed and Nabila Anam</i>	
A New Implimentation Of Catheterization Laboratory	543
<i>Dr.M Madhu, Gerthruth J Mary, P Dhivya Bharathi and D John Ruban</i>	
A Privacy Preservation Scheme in Cloud Environment	549
<i>Ashalatha Lakshmana and Jayashree Agarkhed</i>	

Computational Intelligence, Communications, and Business Analytics

First International Conference, CICBA 2017
Kolkata, India, March 24–25, 2017
Revised Selected Papers, Part I



Part 1

 Springer

J.K. Mandal · Paramartha Dutta
Somnath Mukhopadhyay (Eds.)

Computational Intelligence, Communications, and Business Analytics

First International Conference, CICBA 2017
Kolkata, India, March 24–25, 2017
Revised Selected Papers, Part I

 Springer

Editors

J.K. Mandal
Department of Computer Science
and Engineering
University of Kalyani
Kalyani, West Bengal
India

Somnath Mukhopadhyay
Department of Information Technology
Calcutta Business School
Kolkata
India

Paramartha Dutta
Department of Computer and System
Sciences
Visva Bharati University
Bolpur Santiniketan, West Bengal
India

ISSN 1865-0929 ISSN 1865-0937 (electronic)
Communications in Computer and Information Science
ISBN 978-981-10-6426-5 ISBN 978-981-10-6427-2 (eBook)
DOI 10.1007/978-981-10-6427-2

Library of Congress Control Number: 2017953403

© Springer Nature Singapore Pte Ltd. 2017

This work is subject to copyright. All rights are reserved by the Publisher, whether the whole or part of the material is concerned, specifically the rights of translation, reprinting, reuse of illustrations, recitation, broadcasting, reproduction on microfilms or in any other physical way, and transmission or information storage and retrieval, electronic adaptation, computer software, or by similar or dissimilar methodology now known or hereafter developed.

The use of general descriptive names, registered names, trademarks, service marks, etc. in this publication does not imply, even in the absence of a specific statement, that such names are exempt from the relevant protective laws and regulations and therefore free for general use.

The publisher, the authors and the editors are safe to assume that the advice and information in this book are believed to be true and accurate at the date of publication. Neither the publisher nor the authors or the editors give a warranty, express or implied, with respect to the material contained herein or for any errors or omissions that may have been made. The publisher remains neutral with regard to jurisdictional claims in published maps and institutional affiliations.

Printed on acid-free paper

This Springer imprint is published by Springer Nature
The registered company is Springer Nature Singapore Pte Ltd.
The registered company address is: 152 Beach Road, #21-01/04 Gateway East, Singapore 189721, Singapore

Contents – Part I

Invited Paper

Effect of a Push Operator in Genetic Algorithms for Multimodal Optimization.	3
<i>Yashesh Dhebar and Kalyanmoy Deb</i>	
Stock Price Forecasting with Empirical Mode Decomposition Based Ensemble ν -Support Vector Regression Model	22
<i>Xueheng Qiu, Huilin Zhu, P.N. Suganthan, and Gehan A.J. Amaratunga</i>	
Business Analytics Using Recommendation Systems	35
<i>L.M. Patnaik and Srinidhi Hiriyannaiah</i>	
Directional Changes: A New Way to Look at Price Dynamics	45
<i>Edward P.K. Tsang</i>	

Data Science and Advanced Data Analytics

A Storage Model for Handling Big Data Variety.	59
<i>Anindita Sarkar and Samiran Chattopadhyay</i>	
Conceptual Modelling of Assistance System Based on Analytical Determination of Factors Related to Safety in Automotive Driving in Indian Context	72
<i>Debraj Bhattacharjee, Prabha Bhola, and Pranab K. Dan</i>	
Leveraging Polarity Switches and Domain Ontologies for Sentiment Analysis in Text	84
<i>Srishti Sharma, Shampa Chakraverty, and Anisha Jauhari</i>	
The Online Evaluation System in Sciences Course for Students in Remote Areas: Enhancing Educational Opportunities for All Students Toward Thailand 4.0.	93
<i>Piyanuch Charernmool, Anirach MingKhwan, and Porawat Visutsak</i>	
A Prototype for Sentiment Analysis Using Big Data Tools.	103
<i>Kusum Yadav, Siddharth Swarup Rautaray, and Manjusha Pandey</i>	
A Novel Hybrid Technique for Big Data Classification Using Decision Tree Learning.	118
<i>Khyati Ahlawat and Amit Prakash Singh</i>	

FPGA Based Low Power Hardware Implementation for Quality Access Control of a Compressed Gray Scale Image	416
<i>Himadri Mandal, Goutam Kr. Maity, Amit Phadikar, and Tien-Lung Chiu</i>	
A Proposal for Detection Ethanol Leakage Using WO ₃ Thin Film Sensor with RFID Technology	431
<i>Subhashis Roy, Bikram Biswas, Anup Dey, Bijoy Kantha, and Subir Kumar Sarkar</i>	
Optimization Using Swarm Intelligence and Dynamic Graph Partitioning in IoE Infrastructure: Fog Computing and Cloud Computing	440
<i>Subhrapratim Nath, Arnab Seal, Titir Banerjee, and Subir Kumar Sarkar</i>	
Design and Performance Analysis of a Modified MRAC for Second-Order Integrating Processes	453
<i>Reshma Sengupta and Chanchal Dey</i>	
VHDL Implementation of NOC Architecture for UART Using Round Robin Arbiter	467
<i>Beauti Khataniar and Manoj Kumar</i>	
Computational Forensics (Privacy and Security)	
High Entropy and Avalanche Based Non-Feistel Cascaded CFB Block Cipher Through RSBPNDS and TE.	485
<i>Rajdeep Chakraborty, Runa Seth, and J.K. Mandal</i>	
Cross Platform Chat Application Using ID Based Encryption	495
<i>Aritro Sengupta, Tapobrata Dhar, Sujoy Kumar Das, and Utpal Kumar Ray</i>	
Reversible Watermarking Scheme Using PVD-DE	511
<i>Pabitra Pal, Partha Chowdhuri, and Biswapati Jana</i>	
Brain Signal Based Biometric Identification Using One-Dimensional Local Gradient Pattern and Artificial Neural Network	525
<i>Abeg Kumar Jaiswal and Haider Banka</i>	
A Secure and Privacy Preserving Remote User Authentication Protocol for Internet of Things Environment	537
<i>Preeti Chandrakar and Hari Om</i>	
Number System Oriented Text Steganography in Various Language for Short Messages	552
<i>Santanu Koley and Kunal Kumar Mandal</i>	

High Entropy and Avalanche Based Non-Feistel Cascaded CFB Block Cipher Through RSBPNDS and TE

Rajdeep Chakraborty¹(✉), Runa Seth¹, and J.K. Mandal²

¹ Department of CSE, Netaji Subhash Engineering College, Techno City, P.O. Panchpota, Garia, Kolkata 700152, West Bengal, India
rajdeep_chak@rediffmail.com, runaseth2006@gmail.com

² Department of CSE, University of Kalyani, Kalyani, West Bengal, India
jkmandal@rediffmail.com

Abstract. Security solutions in today's data driven solutions have become an inevitable part. Through this privacy, confidentiality and trust can be achieved and this cascaded technique is proposed. Cryptography is most preferred methods to achieve these goals and cryptography is implemented/realized through applied mathematics. Symmetric key cryptography is most efficient method for the security of big data and almost all established symmetric key algorithms; Triple Data Encryption Standard, International Data Encryption Algorithm, Advanced Encryption Standard; are based on Feistel block cipher. This proposed cascaded technique is a non-Feistel block cipher where plaintext is divided into n number of blocks and each blocks are applied with two encryption functions; Recursive Selected Block Prime-Non-Prime Differential Substitution and Triangular Encryption; in cascaded manner. To achieve good entropy and avalanche; one can apply Cipher Feedback mode to generate final ciphertext by encrypting block by block. This proposed cascaded technique; for its feasibility; is compared with RSA in non-homogeneity, N-gram, floating frequency, avalanche ratio test and entropy test.

Keywords: Symmetric block cipher · Cascading · RSBPNDS · TE · CFB · XOR · Entropy · Avalanche · N-gram · Floating frequency

1 Introduction

The cascaded technique is proposed to achieve the goals of confidentiality, security, privacy and private key based trust/authentication of big data [1–6]. Symmetric key cryptography [6, 8] is efficient accepted methods to achieve this goal. The proposed cascaded technique is non-Feistel block cipher [6] and implemented in bit level to encrypt a big data [5]. Cipher Feedback (CFB) [6] mode is also incorporated to encrypt block by block to get high avalanche ratio and high entropy ratio [3, 6]. Entropy is degree of randomness and it counter many attacks like brute-force-attack, known plaintext attack, known ciphertext attack and plaintext-ciphertext pair attack [6, 10].

GET PRINT BOOK

No eBook available

Springer Shop
Reelf Books
Pibokart
Infoexam

Find in a library
All sellers >

2 Reviews
Write review

Emerging Technologies in Data Mining and Information Security, Volume 2
By Ajith Abraham

Search in this book | Go

About this book

Shop for books on Google Play
Browse the world's largest eBookstore and start reading today on the web, tablet, phone or ereader.
Go to Google Play Now >

My library
My history
Books on Google Play
My library
My history
Books on Google Play

Springer
Pages displayed by permission of Springer. Copyright.

Advances in Intelligent Systems and Computing 813

Ajith Abraham · Paramartha Dutta
Jyotsna Kumar Mandal
Abhishek Bhattacharya · Soumi Dutta
Editors

Emerging Technologies in Data Mining and Information Security

Proceedings of IEMIS 2018, Volume 2

 Springer

This is a preview. The total pages displayed will be limited.

GET PRINT BOOK

No eBook available

Springer Shop
Rediff Books
Flipkart
Infocart

Find in a library
All sellers >

 ⭐⭐⭐⭐
0 Reviews
Write review

Emerging Technologies in Data
Mining and Information Security,
Volume 2
By Ajith Abraham

Search in this book

About this book



Shop for books on Google Play
Browse the world's largest eStore and start reading today on the web, tablet, phone, or reader.

Go to Google Play Now >

My library
My History
Books on Google Play

 Springer
Pages displayed by permission of Springer. Copyright.

Editors
Ajith Abraham
Machine Intelligence Research Labs
Aurham, WA, USA

Paramartha Dutta
Department of Computer and System
Sciences
Vivek-Bharati University
Santiniketan, West Bengal, India

Jyotirm Kumar Mondal
Department of Computer Science
and Engineering
University of Kalyani
Kalyan, India

Abhishek Bhattacharya
Institute of Engineering and Management
Kolkata, West Bengal, India

Soumi Dutta
Institute of Engineering and Management
Kolkata, West Bengal, India

ISSN 2194-5357 ISSN 2194-5365 (electronic)
Advances in Intelligent Systems and Computing
ISBN 978-981-13-1497-7 ISBN 978-981-13-1498-8 (eBook)
https://doi.org/10.1007/978-981-13-1498-8
Library of Congress Control Number: 2018042581

© Springer Nature Singapore Pte Ltd 2019
This work is subject to copyright. All rights are reserved by the Publisher, whether the whole or part of the material is concerned, specifically the rights of translation, reprinting, reuse of illustrations, recasting, broadcasting, reproduction or distribution in any form or by any means, and transmission or information storage and retrieval, electronic adaptation, computer software, or by similar or dissimilar methodology now known or hereafter developed.
The use of general descriptive names, registered names, trademarks, service marks, etc. in this publication does not imply, even in the absence of a specific statement, that such names are exempt from the relevant protective laws and regulations and therefore free for general use.
The publisher, the authors and the editors are not to be held liable for any errors or for any consequences arising from the use of the information contained in this book, whether the publisher or the authors or the editors are aware of any such errors or consequences or for any damages or injuries that may have been made. The publisher remains neutral with regard to jurisdictional claims in published maps and institutional affiliations.

This Springer imprint is published by the registered company Springer Nature Singapore Pte Ltd. The registered company address is: 152 Beach Road, #21-01/02 Gateway East, Singapore, 109951, Singapore.

ThoughtSpring

Some pages are omitted from this book preview.

GET PRINT BOOK

No eBook available

Springer Shop
Rediff Books
Flipkart
infocart

Find in a library
All sellers >

 0 Reviews
Write review

Emerging Technologies in Data Mining and Information Security, Volume 2
By Ajith Abraham

Search in this book

About this book

Shop for Books on Google Play
Browse the world's largest eStore and start reading today, on the web, tablet, phone, or eReader.
Go to Google Play Now >

My library
My history
Books on Google Play

 Springer
Pages displayed by permission of Springer. Copyright.

Some pages are omitted from this book preview.

Contents

Part I Data Analytics

Sentiment Analysis of Tweet Data: The Study of Sentimental State of Human from Tweet Text S. M. Mazharul Hoque Chowdhury, Priyanka Ghosh, Sheikh Abujaer, Most. Abu. Afan and Syed Akhter Hossain	3
Data Analytic Techniques with Hardware-Based Encryption for High-Profile Dataset M. Shammila Begum and A. George	15
Exploring Student Migration in Rural Region of Bangladesh Arifur Bin Hussain, Saikub Moska, Sheikh Nabil Mohammad and Md. R. Azim	25
Analysis on Lightning News and Correlation with Lightning Imaging Sensor (LIS) Data Sunay Chowdhury, K. M. Sajjadul Islam, Sheikh Nabil Mohammad, Md. R. Azim and Choudhury Wahid	37
A Computational Approach for Project Work Performance Analysis Based on Online Collaborative Data Nikitaben P. Shelke and Purnam Gupta	49
Design of Business Canvas Model for Social Media Jan Hruska and Petra Maresova	63
Horticultural Approach for Detection, Categorization and Enumeration of On Plant Oval Shaped Fruits Santii Kumari Behera, Jnanli Jasmine Jena, Aniya Kumar Rath and Prabru Kumar Sethy	71

ix

GET PRINT BOOK

No eBook available

Springer Shop
Rediff Books
Flipkart
Infocart

Find in a library
All sellers >

 0 Reviews
Write review

Emerging Technologies in Data Mining and Information Security, Volume 2
By Ajith Abraham

Search in this book

About this book

Shop for books on Google Play
Browse the world's largest eStore and read reading today on the web, tablet, phone, or reader.
Go to Google Play Now >

My library
My History
Books on Google Play

 Springer
Pages displayed by permission of Springer. Copyright.

xx

Contents

A Novel Deterministic Framework for Non-probabilistic Recommender Systems Avinash Bhar, Divya Madhav Karath and C. Anitha	85
EEG Signal Analysis Using Different Clustering Techniques Chinmaya Kumar Pradhan, Sharat Rahaman, Md. Abdul Alam Sheikh, Alak Kole and Tanmoy Maity	99
Automatic Geospatial Objects Classification from Satellite Images Sharat Rahaman, Md. Abdul Alam Sheikh, Alak Kole, Tanmoy Maity and Chinmaya Kumar Pradhan	107
RATA: Recommending Accepted Answer Using Textual Metadata Md. Mostajid Islam, SK. Shauful Islam, Anfar, Md. Shakil Hossain, Md. Mahmudur Rahman, Md. Mahmudul Hasan, S. M. Al-Hossain Imam, Swakkar Shatabda and Tamanna Islam Jhobi	119
LiUBoost: Locality Informed Under-Boosting for Imbalanced Data Classification Sajid Ahmed, Farhad Roshan, Asif Mubib, Md. Rafsan Jani, Swakkar Shatabda and Dewan Md. Farid	133
Comparative Study of Different Ensemble Compositions in EEG Signal Classification Problem Ankita Datta and Rajdeep Chatterjee	145
Improving Quality of Fruits Picked in Orchards Using Mahalanobis Distance Based Model Kulaivaran Sandamurthy and Kalpana Ramamujam	155
Viable Crop Prediction Scenario in BigData Using a Novel Approach Shriya Sahu, Meenu Chawla and Nilay Khare	165
A Graph Based Approach on Extractive Summarization Madhurma Datta, Aji Kumar Das, Chirantana Mallick, Apurba Sarkar and Ash K. Das	170
Targeted Marketing and Market Share Analysis on POS Payment Data Using DW and OLAP Girishar Maji, Lalit Mohan Datta and Soumya Sen	189
Promises and Challenges of Big Data in a Data-Driven World Somali Mukherjee, Manoj Kumar Mishra and Ishabum Shankar Prasad Mishra	201

GET PRINT BOOK

No eBook available

Springer Shop
Reflit Books
Flipkart
Infocam

Find in a library
All sellers >

 5.0
0 Reviews
Write review

Emerging Technologies in Data Mining and Information Security, Volume 2
By Ajay Abraham

Search in this book

About the book



Shop for books on Google Play

Browse the world's largest eBookstore and start reading today, on the web, on your tablet, or on your phone.

Go to Google Play Now >

My library
My History
Books on Google Play

 Springer

Pages displayed by permission of Springer. Copyright.

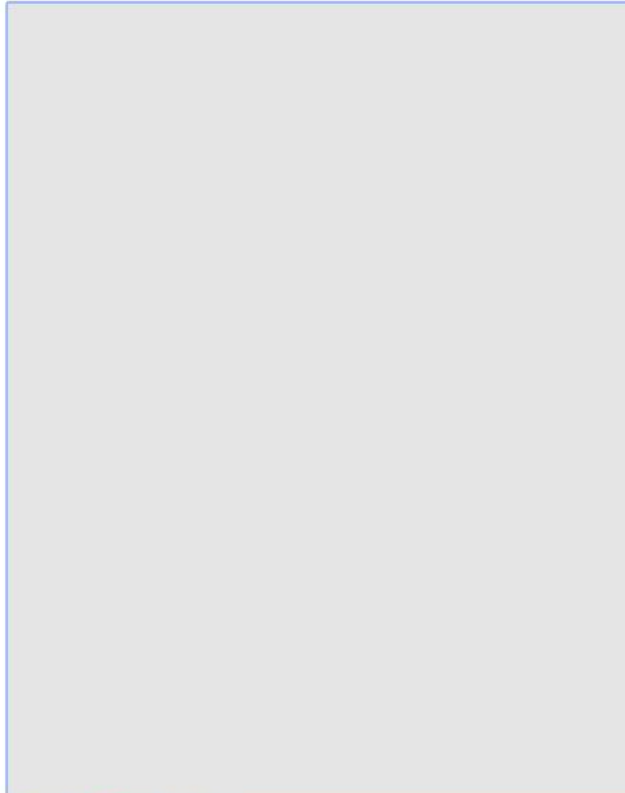

Contents

Accelerating Pairwise Sequence Alignment Algorithm by MapReduce Technique for Next-Generation Sequencing (NGS) Data Analysis	213
Sudip Mondal and Sumit Khatua	
Entity Resolution in Online Multiple Social Networks (Facebook and LinkedIn)	221
Ravita Mishra	
Big Data Approach for Epidemiology and Prevention of HIV/AIDS	239
Nivedita Das, Sanjeev Agarwal, Siddharth Swarnp Rautaray and Manjusha Pandey	
A Survey on Local Market Analysis for a Successful Restaurant Yield	249
Bilisha Das Bakti, Vashu Rao and C. Anitha	
Context Dependency Relation Extraction Using Modified Evolutionary Algorithm Based on Web Mining	259
Parinda Prajapati and Premkumar Sivakumar	
NoSQL Overview and Performance Testing of HBase Over Multiple Nodes with MySQL	269
Nabendu Das, Swagata Paul, Bikyut Binan Sarkar and Satyaji Chakrabarti	
NO SQL Approach for Handling Bioinformatics Data Using MongoDB	281
Swarnop Chigrapati, Kinnu Vegeeta, L. V. Siva Rama Krishna Bokka, Gopala Krishna Murthy Nookala and Suresh B. Mudumoti	
Thunderstorm Characteristics Over the Northeastern Region (NER) of India During the Pre-monsoon Season, 2011 Using Geosynchronous Satellite Data	289
Sandeep Thakur, Ismail Mondal, Phani Bhushan Ghosh and Tarun Kumar De	
A Novel Approach to Spam Filtering Using Semantic Based Naive Bayesian Classifier in Text Analytics	301
Ritik Malik and Abhaya Kumar Sahoo	
A Proposed Approach for Improving Hadoop Performance for Handling Small Files	311
Arshad Karan, Siddharth Swarnp Rautaray and Manjusha Pandey	
To Ameliorate Classification Accuracy Using Ensemble Vote Approach and Base Classifiers	321
Mudasir Ashraf, Majid Zaman and Mohcet Ahmed	

Copyrighted material

GET PRINT BOOK

No eBook available

Springer Shop
Rediff Books
Piplakart
Infocart

Find in a library
All sellers >

 0 Reviews
Write review

Emerging Technologies in Data Mining and Information Security, Volume 2
By Ajith Abraham

Search in this book

About this book

Shop for books on Google Play
Browse the world's largest eStore and start reading today, on the web, tablet, phone, or reader.
Go to Google Play Now >

My library
My History
Books on Google Play

 Springer
Pages displayed by permission of Springer. Copyright.

xi	Contents
Big Data Ecosystem: Review on Architectural Evolution 335 Kamaksha Narain Singh, Rajat Kumar Behera and Jibendu Kumar Mantri	
A Comparative Study of Local Outlier Factor Algorithms for Outliers Detection in Data Streams 347 Supriya Mishra and Meemi Chavala	
Context Level Entity Extraction Using Text Analytics with Big Data Tools 357 Papiya Das, Kausyap Barua, Manjusha Pandey and Siddharth Swarup Routany	
A Novel Hybrid Approach for Time Series Data Forecasting Using Moving Average Filter and ARIMA-SVM 369 Gurudev Anandhye, A. C. S. Rao and M. D. Mastan Mohammad	
Social Network Analysis with Collaborative Learning: A Review 383 Abhishek Kashyap and Sri Katerwar Saraha	
Frequent Subpatterns Distribution in Social Network Analysis 393 Rahul Rane	
Big Data Real-Time Storytelling with Self-service Visualization 405 Raja Kumar Behera and Anil Kumar Swain	
Informative Gene Selection Using Clustering and Gene Ontology 417 Soumen K. Pan, Subhankar Mallick, Annu Chakraborty and Ankur Das	
Part II - Data Mining	
Identifying Categorical Terms Based on Latent Dirichlet Allocation for Email Categorization 431 Atanksha Sharaff and Nareesh Kumar Negwan	
The Role of Social Media in Crisis Situation Management: A Survey 439 Akanisha Gool, Manomita Chakraborty and Sanj Kumar Biswas	
Subset Significance Threshold: An Effective Constraint Variable for Mining Significant Closed Frequent Itemsets 449 S. Pavitra Bai and G. K. Ravi Kumar	
An Automated Method for Power Line Points Detection from Terrestrial LiDAR Data 459 Anshul Husain and Rakesh Chandra Vaidhya	
Stochastic Petri Net Based Modeling for Analyzing Dependability of Big Data Storage System 473 Durbadal Chitambar, Menalissa Sima and Debasis Samanta	

GET PRINT BOOK

No eBook available

Springer Shop
Rediff Books
Flipkart
Infocam

Find in a library
All sellers >

 0 Reviews
Write review

Emerging Technologies in Data Mining and Information Security, Volume 2
By Ajith Abraham

Search in this book

About this book



Shop for Books on Google Play

Browse the world's largest eBookstore and start reading today on the web, tablet, phone, or eReader.

Go to Google Play Now >

My library

My History

Books on Google Play

 Springer

Pages displayed by permission of Springer. Copyright.

Contents	xxii
Sachetan: A Crowdsourc-Based Personal Safety Application	485
<small>Sheikh Nabil Mohammad, Sakawat Hossain, Md. Masajjur Rahman, Mitran Das and Md. R. Amin</small>	
Cyberbullying and Self-harm in Adolescence, an Assessment of Detection, Prevention, and Recovery from Forum	497
<small>A. Sandrine Pricilla, I. Anandhi and J. L. Sheeba</small>	
Visual Verification and Analysis of Outliers Using Optimal Outlier Detection Result by Choosing Proper Algorithm and Parameter	507
<small>Bilkis Jamil Ferdosi and Muhammad Masud Tarck</small>	
Identification of the Recurrence of Breast Cancer by Discriminant Analysis	519
<small>Avijit Kumar Chaudhuri, D. Sinha and K. S. Thyagaraj</small>	
Automatic Multi-class Classification of Beetle Pest Using Statistical Feature Extraction and Support Vector Machine	533
<small>Abhishek Dey, Debansmita Bhattachik and Kashi Nath Dey</small>	
Probabilistic Dimension Reduction Method for Privacy Preserving Data Clustering	545
<small>Hanumantha Rao Jalla and P. N. Giritja</small>	
Spam Detection in SMS Based on Feature Selection Techniques	555
<small>Aikanksha Shrivast</small>	
Recent Trends of Data Mining in Cloud Computing	565
<small>Abhijit Sarkar, Abhishek Bhattacharya, Soumi Dutta and Komal K. Patil</small>	
Impact of Data Mining Techniques in Predictive Modeling: A Case Study	579
<small>Saparna DasGupta, Soumyabrata Saha and Saman Kumar Das</small>	
Distortion-Based Privacy-Preserved Association Rules Mining Without Side Effects Using Closed Items	591
<small>H. Suresh and H. S. Mohan</small>	
A Data Warehouse Based Schema Design on Decision-Making in Loan Disbursement for Indian Advance Sector	603
<small>Indira Das, Santanu Roy, Anjan Chatterjee and Susmita Sen</small>	
Analysis and Design of an Efficient Temporal Data Mining Model for the Indian Stock Market	615
<small>Cerece Mariam Abraham, M. Sudheep Elayidom and T. Sathyanakrishnan</small>	
Shilling Attack Detection in Recommender System Using PCA and SVM	629
<small>Noopur Samsiya, Sandeep K. Raghuvanshi and R. K. Pateriya</small>	

GET PRINT BOOK

No eBook available

Springer Shop
Rediff Books
Flipkart
Infocart

Find in a library
All sellers >

 0 Reviews
Voice review

Emerging Technologies in Data Mining and Information Security, Volume 2
By Ajith Abraham

Search in this book

About this book

Shop for books on Google Play
Browse the world's largest eBookstore and start reading today on the web, tablet, phone, or eReader.
Go to Google Play Now >

• My library
• My history
Books on Google Play

 Springer
Pages displayed by permission of Springer. Copyright.

xxiv Contents

A Hybrid Clustering Algorithm Based on Kmeans and Ant Lion Optimization	639
Santosh Kumar Majhi and Shubhra Biswal	
Flight Arrival Delay Prediction Using Gradient Boosting Classifier	651
Navoneel Chakrabarty, Tuhin Kunchu, Sadipati Dandapat, Apurba Sarkar and Dipak Kumar Kole	
The Prediction of Traffic Flow with Regression Analysis	661
Ishicaqa Alam, Dewan Md. Farid and Rossido J. F. Rossetti	
SBI-MSREImpute: A Sequential Biclustering Technique Based on Mean Squared Residue and Euclidean Distance to Predict Missing Values in Microarray Gene Expression Data	673
Soumya Datta, Mihala Hoss, Fuzur Ahmad, Aram Saha, Manraj Kumar and Chandra Das	
FTD Tree Based Classification Model for Alzheimer's Disease Prediction	687
Bala Rabinowami Kalluri, M. Uma Maheswara Rao and S. Narayana	
Data Mining in Frequent Pattern Matching Using Improved Apriori Algorithm	699
Bhishya Krishna and Geetanjali Amarawat	
A Model for Predicting Outfit Sales: Using Data Mining Methods	711
Mohammad Anwar Ullah	
A Novel Feature Selection Technique for Text Classification	721
D. S. Gunu, Mostafa Ali and Muhammad Suhil	
Prediction of Death Rate Using Regression Analysis	735
Satya Ranjan Dash and Rekha Satu	
An Investigative Prolegomenon on Various Clustering Strategies, Their Resolution, and Future Direction Towards Wireless Sensor Systems	747
Sushree Bibhuprada B. Priyadarshini, Aniya Bhusan Bugadab, Survasini Pratiygrhi and Brojo Kishore Mishra	
A Comparison Study of Temporal Signature Mining Over Traditional Data Mining Techniques to Detect Network Intrusion	757
Sharmistha Dutta, Tanuja Mawla and Md. Forhad Rabbi	
An Optimized Random Forest Classifier for Diabetes Mellitus	765
N. Komal Kumar, D. Vigneshwari, M. Vamsi Krishna and G. V. Phanindra Reddy	

Get Print Book

No eBook available

Springer Shop
Reaff Books
Flipkart
Infocart

Find in a library
All sellers

 ⭐⭐⭐⭐⭐
0 Reviews
Write review

Emerging Technologies in Data
Mining and Information Security,
Volume 2
By Ajith Abraham
Search in this book

About this book



Shop for Books on Google Play
Browse the world's largest eBookstore
and start reading today on the web,
table, phone, or e-reader.
Go to Google Play Now >

• My library
• My History
Books on Google Play

 Springer
Pages displayed by permission of
Springer. Copyright.

Contents xxv

Development of Cardiac Disease Classifier Using Rough Set Decision System	775
B. Haldar, S. Maiti and M. Maiti	
Decision Support System for Prediction of Occupational Accident: A Case Study from a Steel Plant	787
Sobhan Sarkar, Mritak Chakraborty, Sobin Nayak and J. Maiti	
Community Detection Based Tweet Summarization	797
Soumi Dutta, Asit Kumar Das, Abhishek Bhattacharya, Gourav Dutta, Komal K. Parikh, Anil Das and Dipso Ganguly	
Heart Diseases Prediction System Using CHC-TSS Evolutionary, KNN, and Decision Tree Classification Algorithm	809
Rishabh Saxena, Aakriti Jothi, Vikas Deep and Parashoram Sharma	
Electrodes Analysis of Well Log Data Using Data Mining Algorithms: A Case Study	821
Sanjuku De, Goutam Prasad Nigadkar and Debasish Sengupta	
A Dynamic Spatial Fuzzy C-Means Clustering-Based Medical Image Segmentation	829
Anirya Haldar, Avranil Maiti, Apurba Sarkar and Ananya Das	
Text-Based Emotion Analysis: Feature Selection Techniques and Approaches	837
Prathamesh Apte and Saritko Sri Khetwat	
Community Detection Methods in Social Network Analysis	849
Ilho and Sri Khetwat Sartha	
Summarizing Microblogs During Emergency Events: A Comparison of Extractive Summarization Algorithms	859
Soumi Dutta, Vireesh Chandra, Kamal Mehra, Sujata Ghatak, Asit Kumar Das and Saptarshi Ghosh	
A Comparative Study on Cluster Analysis of Microblogging Data	873
Soumi Dutta, Asit Kumar Das, Gourav Dutta and Manan Gupta	
Author Index	883

GET PRINT BOOK

No eBook available

Springer Shop
ReDF Books
Flipkart
Infocart

Find in a library
All sellers >

Emerging Technologies in Data Mining and Information Security, Volume 2
By Ajith Abraham

SBI-MSREimpute: A Se Go

About this book

Shop for books on Google Play
Browse the world's largest eStore and start reading today on the web, tablet, phone, or reader.
Go to Google Play Now >

My library
My History
Books on Google Play

Springer
Pages displayed by permission of Springer. Copyright.

Result 2 of 3 in the book for SBI-MSREimpute: A Sequential Biclustering Technique based on Mean Squared Residue and Euclidean Distance to Predict Missing Values in Microarray Gene Expression Data - [Download text] - View all

SBI-MSREimpute: A Sequential Biclustering Technique Based on Mean Squared Residue and Euclidean Distance to Predict Missing Values in Microarray Gene Expression Data

Sourav Datta, Mihiba Hare, Faraz Ahmad, Anam Saha, Mamraj Kumar and Chandra Das

Abstract Due to technical problems in DNA microarray technology, the output matrix named gene expression data contains a huge number of missing entries. These missing entries create problems when analysis algorithms like classification, clustering, etc. are applied on microarray gene expression data as these methods require complete data matrix. To solve the above-mentioned problem, several missing value imputation techniques have been developed. Among them clustering- and biclustering-based missing value prediction methods are more popular due to their simplicity. In this regard, here a new biclustering-based sequential imputation method is proposed. In this method, for every missing position, a bicluster is formed in a novel manner using the concept of mean squared residue (MSR) score and Euclidean distance. Then the imputation is carried out sequentially by computing the weighted average of the neighbour genes and samples present in the bicluster. To evaluate the

S. Datta - M. Hare - F. Ahmad - A. Saha - M. Kumar - C. Das (Eds)
Nriag Sankh Engineering College, Guria, Kolkata 700152, India
e-mail: dattasourav@gmail.com

S. Datta
e-mail: dattasourav@gmail.com

M. Hare
e-mail: mihibahare@gmail.com

F. Ahmad
e-mail: faraz72@gmail.com

A. Saha
e-mail: anam.saha78@gmail.com

M. Kumar
e-mail: rajmamraj124@gmail.com

© Springer Nature Singapore Pte Ltd. 2019
A. Abraham et al. (eds.), *Emerging Technologies in Data Mining and Information Security: Advances in Intelligent Systems and Computing* 515.
https://doi.org/10.1007/978-981-13-1498-8_59

672

Sign In Register

HOME | ABOUT US | CONTACT | FAQ | VIEW CART

Cart 0 Items: \$0.00
Call Toll-Free (USA)
866-964-0401

DISCOUNTED SHIPPING
On International Orders
Click for Details

Curran Associates Inc. **proceedings.com**

Conference Proceedings Specialists

Enter Keywords Search Partners News General Info

Browse by Publisher
Browse by Category

- Aerospace
- Agriculture
- Biology - Medicine
- Chemical - Petroleum
- Civil
- Electrical - Computer
- Environmental
- Geoscience - Mining
- Materials Science
- Mechanical
- Nanotechnology
- Physica - Nuclear - Math
- Other

Partner With Us!
Consider partnering with Curran to get your titles listed here!

Featured On Ezine Articles

Home > Browse by Publisher > Institute of Electrical and Electronics Engineers (IEEE) > ADVANCES IN COMPUTING, COMMUNICATIONS AND INFORMATICS, INTERNATIONAL CONFERENCE, 2016 (ICACCI 2016) (4 VOL S)

 Send to Friend

ADVANCES IN COMPUTING, COMMUNICATIONS AND INFORMATICS, INTERNATIONAL CONFERENCE, 2016 (ICACCI 2016) (4 VOL S)

Item #: 32058

Our Price: \$700.00

Pricing: [Non-Member \$700.00]

IEEE Member #:

ADD TO CART

Product Description

Title: 2016 International Conference on Advances in Computing, Communications and Informatics (ICACCI 2016)

Desc: Proceedings of a meeting held 21-24 September 2016, Jaipur, India.

Desc: Proceedings of a meeting held 21-24 September 2016, Jaipur, India.

Proof: CFP16CAF-POD

ISBN: 9781509020300

Pages: 2,781 (4 Vols)

Format: Softcover



Notes: Authorized distributor of all IEEE proceedings

TOC: [View Table of Contents](#)

Publ: Institute of Electrical and Electronics Engineers (IEEE)

POD Publ: Curran Associates, Inc. (Dec 2016)

Related Products

-  COMMUNICATIONS, IEEE INTERNATIONAL CONFERENCE, 2006. (12 VOL S)
-  DESIGN AUTOMATION AND TEST IN EUROPE, CONFERENCE, 2006. (3 VOL S)
-  WIRELESS AND OPTICAL COMMUNICATIONS NETWORKS, IFIP INTERNATIONAL CONFERENCE, 2006. (2 VOL S)

Testimonials "We are very satisfied with our relationship over the years with Curran, look forward to future business collaborations, and highly recommend Curran Associates" — Gail Oare, Director of Publications and Marketing, MRS Curran's print on-demand service allows us to continue to provide our members and customers with print versions of our content that is not cost-effective for us to produce on a large scale — Gail Oare, Director of Publications and Marketing

2016 International Conference on Advances in Computing, Communications and Informatics (ICACCI 2016)

**Jaipur, India
21-24 September 2016**

Pages 1-692



**IEEE Catalog Number: CFP16CAF-POD
ISBN: 978-1-5090-2030-0**

**Copyright © 2016 by the Institute of Electrical and Electronics Engineers, Inc
All Rights Reserved**

Copyright and Reprint Permissions: Abstracting is permitted with credit to the source. Libraries are permitted to photocopy beyond the limit of U.S. copyright law for private use of patrons those articles in this volume that carry a code at the bottom of the first page, provided the per-copy fee indicated in the code is paid through Copyright Clearance Center, 222 Rosewood Drive, Danvers, MA 01923.

For other copying, reprint or republication permission, write to IEEE Copyrights Manager, IEEE Service Center, 445 Hoes Lane, Piscataway, NJ 08854. All rights reserved.

******This publication is a representation of what appears in the IEEE Digital Libraries. Some format issues inherent in the e-media version may also appear in this print version.***

IEEE Catalog Number:	CFP16CAF-POD
ISBN (Print-On-Demand):	978-1-5090-2030-0
ISBN (Online):	978-1-5090-2029-4

Additional Copies of This Publication Are Available From:

Curran Associates, Inc
57 Morehouse Lane
Red Hook, NY 12571 USA
Phone: (845) 758-0400
Fax: (845) 758-2633
E-mail: curran@proceedings.com
Web: www.proceedings.com

CURRAN ASSOCIATES INC.
proceedings
.com

2016 International Conference on Advances in Computing, Communications and Informatics (ICACCI'16), Sept. 21-24, 2016, Jaipur, India

TABLE OF CONTENTS

ICACCI-01: Best Paper Session-I

<i>A Cost-Effective Solution for Pedestrian Localization in Complex Indoor Environment</i> Prachi Kudeshia (The LNM Institute of Information Technology Jaipur, India), Santosh Shah (The LNM Institute of Information Technology, Jaipur India, India), Anup Bhattacharjee (The LNMIIT Jaipur, India).....	1
<i>Texture Analysis of Breast Thermogram for Differentiation of Malignant and Benign Breast</i> Sourav Pramanik (Jadavpur University, India), Debotosh Bhattacharjee (Jadavpur University, India), Mita Nasipuri (Jadavpur University, India).....	8
<i>Detection and Retargeting of Emphasized Text for Content Summarization</i> Md Ajj (National Institute of Technology Meghalaya, India), Sanjoy Pratihar (National Institute of Technology Meghalaya, India), Kanishka Ganguly (University of Maryland, USA).....	15
<i>Computational Characterization of Cerebellum Granule Neuron Responses to Auditory and Visual Inputs</i> Chaitanya Medini (Amrita Vishwa Vidyapeetham (Amrita University), India), Arathi Rajendran (Amrita Vishwa Vidyapeetham (Amrita University), India), Aiswarya Jijibai (Amrita Vishwa Vidyapeetham, Amrita University, India), Bipin Nair (Amrita Vishwa Vidyapeetham (Amrita University), India), Shyam Diwakar (Amrita Vishwa Vidyapeetham (Amrita University), India).....	22
<i>Modelling the Undulation Patterns of Flying Snakes</i> Viswesh Sujjur BalaramRaja (Amrita Vishwa Vidhyapeetham, India), Eashwra Sankrityayan S (Amrita Vishwa Vidyapeetham, India), Suraj Coimbatore Sivagurunathan (Amrita Vishwa Vidyapeetham, India), Balajee Ramakrishnananda (Amrita Vishwa Vidyapeetham & Amrita Vishwa Vidyapeetham, India), Rajesh Senthil Kumar T (Amrita Vishwa Vidhyapeetham, India).....	28
<i>Edge PSO - A Recombination Operator Based PSO Algorithm for Solving TSP</i> Vaisakh S (Indian Institute Of Space Science And Technology, India), Akhil P m (Indian Institute Of Space Science And Technology, India), Asharaf S (IITMK, India).....	35
<i>Conditional Adherence Based Classification of Transactions for Database Intrusion Detection and Prevention</i> Indu Singh (Delhi Technological University, India), Vaibhav Darbari (Delhi Technological University, India), Lakshya Kejriwal (Delhi Technological University, India), Aditya Agarwal (Delhi Technological University, India).....	42
<i>Modified Gammatone Frequency Cepstral Coefficients to Improve Spoofing Detection</i> Arun Das K (Amrita Vishwa Vidyapeetham, India), Kuruvachan K George (Amrita Vishwa Vidyapeetham, India), Santhosh C Kumar (Amrita Vishwa Vidyapeetham, India), Veni S (Amrita Vishwa Vidyapeetham, India), Ashish Panda (Tata Consultancy	

Services, India)_____	50
<i>NvCloudIDS: A Security Architecture to Detect Intrusions At Network and Virtualization Layer in Cloud Environment</i> Preeti Mishra (Malaviya National Institute of Technology Jaipur, India), Emmanuel Shubhakar Pilli (Malaviya National Institute of Technology, Jaipur, India), Vijay Varadharajan (Macquarie University, Australia), Udaya Tupakula (Macquarie University, Australia)_____	56
<i>Energy Efficient Algorithms to Maximize Lifetime of Wireless Sensor Networks</i> Srikanth Jannu (Indian School of Mines, India), Prasanta Kumar Jana (Indian School of Mines, India)_____	63

ICACCI-09: Best Paper Session-II

<i>ELM Based Imputation-Boosted Proactive Recommender Systems</i> Punam Bedi (University of Delhi, India), Richa Singh (University of Delhi, India), Sumit Agarwal (University of Delhi & University of Delhi, India), Veenu Bhasin (University of Delhi, India)_____	69
<i>CBCARS: Content Boosted Context-Aware Recommendations Using Tensor Factorization</i> Anjali Gautam (University of Delhi, India), Parila Chaudhary (University of Delhi, India), Kunal Sindhvani (University of Delhi, India), Punam Bedi (University of Delhi, India)_____	75
<i>Penalty Based Weighted Cooperative Spectrum Sensing Using Normal Factor Graph</i> Guman Shekhawat (The LNM Institute of Information Technology, India), Purnendu Karmakar (The LNM Institute of Information Technology, India)_____	82
<i>SIMO Diversity Reception in Rayleigh and Rician Fading with Imperfect Channel Estimation</i> Yash Vasavada (Dhirubhai Ambani Institute of Information and Communication Technology, India), Jeffrey Reed (Virginia Tech, USA), A. A. (Louis) Beex (DSPRL - Wireless@VT & Virginia Tech, USA)_____	88
<i>Power Line Interference Removal From ECG Signals Using Wavelet Transform Based Component-Retrieval</i> Tanushree Sharma (Malaviya National Institute of Technology, India), Kamalesh Kumar Sharma (Malaviya National Institute of Technology, Jaipur, India)_____	95
<i>Automatic Program Generation for Heterogeneous Architectures</i> Deepika H V (C-DAC & C-DAC, India), Mangala N (C-DAC, India), Nelaturu Sarat Chandra Babu (Research & Development, C-DAC, India)_____	102
<i>An Empirical Study to Assess the Effects of Refactoring on Software Maintainability</i> Ruchika Malhotra (Delhi Technological University, India), Anuradha Chug (Guru Gobind Singh Indraprastha University, India)_____	110
<i>Entropy Based Informative Content Density Approach for Efficient Web Content Extraction</i> G. p. Sajeev (Amrita University & Govt Engineering College, India), Manjusha Annam (Amrita Vishwa Vidyapeetham, India)_____	118

ICACCI-02: Signal/Image/video/speech Processing/Computer Vision/Pattern Recognition (Regular Papers)

<i>An Unsupervised Modified Spatial Fuzzy C-mean Method for Segmentation of Brain MR Image</i>	
Kamarujjaman Sk (Govt. College of Engineering and Ceramic Technology, India), Susanta Chakraborty (Indian Institute of Engineering Science and Technology, India), Mausumi Maitra (Govt. College of Engineering and Ceramic Technology, India)	125
<i>On the Adaptive Motion Estimation in Video Coding Based on Video Content Analysis</i>	
Kattula Shyamala (Osmania University College of Engineering, Hyderabad & Department of CSE, India), Mallesham Dasari (Stony Brook University, USA)	132
<i>Real-time Panorama Composition for Video Surveillance using GPU</i>	
Pritam Prakash Shete (Bhabha Atomic Research Centre, India), Dinesh Sarode (Bhabha Atomic Research Centre, India), Surojit Bose (Bhabha Atomic Research Centre, India)	137
<i>Human Action Recognition Using RGB-D Sensor and Deep Convolutional Neural Networks</i>	
Javed Imran (IIT Roorkee, India), Praveen Kumar (Visvesvaraya National Institute of Technology, India)	144
<i>Novel Feature Ranking Criteria for Interval Valued Feature Selection</i>	
Guru D S (University of Mysore, India), Vinay Kumar N (University of Mysore, India)	149
<i>Supervised and Unsupervised Learning in Animal Classification</i>	
N Manohar (University of Mysore, India), Yh Sharath Kumar (MIT Mysore, India), G Hemanthkumar (University Of Mysore, India)	156
<i>Representing Image Captions as Concept Graphs Using Semantic Information</i>	
Swarnendu Ghosh (Jadavpur University, India), Nibaran Das (Jadavpur University, India), Teresa F. Gonçalves (Universidade de Évora, Portugal), Paulo Quaresma (University of Evora, Portugal)	162
<i>Stockwell Transform Based Face Recognition: A Robust and an Accurate Approach</i>	
B H Shekar (Mangalore University, India), Rajesh D S (Mangalore University, India)	168
<i>Recognition of a Person in a Crowd and Occluded Face Images Based on Skin Color Segmentation</i>	
Naveena M (University of Mysore, India), G Hemanthkumar (University Of Mysore, India), P Navya (University of Mysore, India)	175
<i>Online Discriminative Tracking with Optimal Feature Selection</i>	
Kaushik Gowda (MSRUAS, India), Lasitha Mekkyil (M. S. Ramaiah University of Applied Sciences, India), Hariharan Ramasangu (M. S. Ramaiah University of Applied Sciences, India)	180
<i>Brain Tumor Segmentation From MR Brain Images Using Improved Fuzzy c-Means Clustering and Watershed Algorithm</i>	
Benson C C (University of Calicut, India), Deepa V (University of Calicut, India), Lajish Lajish V L (University of Calicut, India), Kumar Rajamani (Robert Bosch Engineering and Business Solutions Limited, India)	187
<i>Content-Aware Image Retargeting with Controlled Distortion for Small Displays</i>	
Prasun Tripathi (Indian Institute of Technology, Patna, India), Rajarshi Pal (Institute for Development and Research in Banking Technology (IDRBT), Hyderabad, India)	193
<i>Video Shot Boundary Detection Using Midrange Local Binary Pattern</i>	
Rashmi B S (Karnataka State Open University (KSOU), India), Nagendraswamy H S (University of Mysore, India)	201

<i>Detection of Aggressive Driving Behavior and Fault Behavior Using Pattern Matching</i> Jessy George Smith (Cognizant Technology Solutions Limited, India), Mandar Patil (Cognizant Technology Solutions, India), Kirthi Ponnuru (Cognizant Technology Solutions, India).....	207
<i>A Scalable and Robust Framework for Intelligent Real-time Video Surveillance</i> Shreenath Dutt Sharma (Indian Institute of Technology (BHU), Varanasi, India), Ankita Kalra (Indian Institute of Technology (BHU), Varanasi, India).....	212
<i>Partial Differential Equation Diffusion in Complex Domain</i> Lanlan Li (Shanghai Bell Software Co., Ltd, Shanghai, P.R. China), Jinsong Wu (Universidad de Chile, Chile).....	216

ICACCI-03: Embedded Systems/Computer Architecture and VLSI/Adaptive Systems/ICAIS'16 (Regular Papers)

<i>Incorporating Adaptivity Using Learning in Avionics Self Adaptive Software A Case Study</i> Rajanikanth Kashi (Honeywell Technology Solutions Laboratories & International Institute of Information Technology, Bangalore, India), Meenakshi DSouza (IIIT-B, India), S Kumar Baghel (International Institute of Information Technology, Bangalore, India), Nitin Kulkarni (International Institute of Information Technology, Bangalore, India).....	220
<i>Area Optimization of Two-Stage Amplifier Using Modified Particle Swarm Optimization Algorithm</i> Smrity Ratan (IIT (BHU), Varanasi, India), Debalina Mondal (NIT Durgapur, India), Anima R (NIT Durgapur, India), Chandan Kumar (IIT (BHU), Varanasi, India), Amit Kumar (IIT (BHU), Varanasi, India), Rajib Kar (National Institute of Technology, Durgapur, India).....	230
<i>Modified 4-2 Compressor Using Improved Multiplexer for Low Power Applications</i> Dinesh Kumar (GGSIPU (USICT) Delhi, India), Manoj Kumar (Guru Gobind Singh Indraprastha University, New delhi, India).....	236
<i>Modeling and Control of One-Link Robotic Manipulator Using Neural Network Based PID Controller</i> Rajesh Kumar (Netaji Subhas Institute of Technology, New Delhi, University Of Delhi, India), Smriti Srivastava (Netaji Subhas Institute of Technology, India), Jai Ram Prasad Gupta (Netaji Subhas Institute of Technology, India).....	243
<i>An Input Test Pattern for Characterization of a Full-Adder and N-Bit Ripple Carry Adder</i> Manan Mewada (Ahmedabad University & School of Engineering and Applied Science, India), Mazad Zaveri (Ahmedabad University & School of Engineering and Applied Science, India).....	250
<i>GFDM/OQAM Implementation Under Rician Fading Channel</i> Shravan Kumar Bandari (National Institute of Technology Warangal, India), Venkata Mani Vakamulla (National Institute of Technology Warangal, India), Anastasios Drosopoulos (TEI of Western Greece, Greece).....	256
<i>Efficient Baseband Processing System for DVB-RCS to DVB-S2 Onboard Processing Satellite</i> Anurag Das (Indus Institute of Technology and Engineering, Indus University, India), Rajat Arora (Space Applications Centre (SAC), ISRO, India), Tvs Ram (Space Applications Centre (SAC), ISRO, India).....	261

<i>Design of Memristor-based Up-Down Counter Using Material Implication Logic</i>	
Anindita Chakraborty (Indian Institute of Engineering Science and Technology, Shibpur, India), Aparna Dhara (Indian Institute of Engineering Science and Technology, Shibpur, India), Hafizur Rahaman (Indian Institute of Engineering Science and Technology, Shibpur, India)	269
<i>A Novel and Efficient Design of Golay Encoder for Ultra Deep Submicron Technologies</i>	
Chiranjeevi Sheelam (Vardhaman College of Engineering & Center of Advanced Research Computing Laboratory, India), Jayanthi V R Ravindra (Center for Advanced Computing Research Lab, India)	275
<i>An Affine Combination of Two Adaptive Filters for System Identification with Variable Sparsity</i>	
Pogula Rakesh (National Institute of Technology Warangal, India), Kishore T (NIT Warangal, India)	281
<i>Design and Simulation of Tri-band Spidron Fractal Equilateral Triangle Microstrip Antenna</i>	
Munish Kumar (USICT, India), Vandana Nath (Guru Gobind Singh Indraprastha University, India)	287
<i>Design and Analysis of Different Types of Charge Pump Using CMOS Technology</i>	
Harshita Dadhich (GITS, India), Vijendra Maurya (Amity University, India), Kumkum Verma (Sangam University, India), Sanjay Jaiswal (Sangam University, India)	294
<i>Biomarker Identification Using Next Generation Sequencing Data of RNA</i>	
Shib Sankar Bhowmick (Heritage Institute of Technology, India), Indrajit Saha (National Institute of Technical Teachers' Training & Research, Kolkata, India), Ujjwal Maulik (Jadavpur University, India), Debotosh Bhattacharjee (Jadavpur University, India)	299
<i>Controlled Motion in X and Y Direction by Piezoelectric Actuation</i>	
Kiran Junagal (Rajasthan Technical University Kota Rajasthan India, India), R. s. Meena (UCE, KOTA, India)	304
<i>Analysis of Fuzzy Rules for Robot</i>	
Sandeep BS (Amrita Vishwa Vidyapeetham, Amrita University, India), Supriya P (Amrita Vishwa Vidyapeetham, Amrita University, India)	309

ICACCI-04: Sensor Networks, MANETs and VANETs/Distributed Systems (Regular Papers)

<i>Compute-Intensive Workflow Scheduling in Multi-Cloud Environment</i>	
Indrajeet Gupta (Indian School of Mines, India), Madhu Sudan Kumar (Indian School of Mines Dhanbad, India), Prasanta Kumar Jana (Indian School of Mines, India)	315
<i>Performance Analysis of Two-Tier Cellular Network Using Power Control and Cooperation</i>	
Pragya Swami (ABV- Indian Institute of Information Technology and Management Gwalior, India), Mukesh Kumar Mishra (ABV- Indian Institute of Information Technology and Management, Gwalior, India), Aditya Trivedi (ABV-Indian Institute of Information Technology and Management Gwalior, India)	322
<i>Energy Harvesting-Based Two-hop D2D Communication in Cellular Networks</i>	
Pooja Lakhlan (ABV-Indian Institute of Information Technology and Management, India), Aditya Trivedi (ABV-Indian Institute of Information Technology and Management Gwalior, India)	328

<i>Interference-Fault Free Transmission Schedule in Tree-structured WSN</i>	
Beneyaz Ara Begum (Academy of Scientific and Innovative Research (AcSIR) & CSIR-Indian Institute of Chemical Technology, India), Satyanarayana V Nandury (CSIR-Indian Institute of Chemical Technology & Academy of Scientific & Innovative Research, India)	333
<i>Measurement Results for File Transfer Using RaptorQ in a Mobile Environment</i>	
John N. Daigle (University of Mississippi, USA), Demba B Komma (University of Mississippi, USA), Feng Wang (The University of Mississippi, USA)	342
<i>LAWI: A Load balanced Architecture for Wireless Network on chip</i>	
Priyanka Mitra (Malaviya National Institute of Technology, India)	349
<i>Strategies to Handle Big Data for Traffic Management in Smart Cities</i>	
Satyanarayana V Nandury (CSIR-Indian Institute of Chemical Technology & Academy of Scientific & Innovative Research, India), Beneyaz Ara Begum (Academy of Scientific and Innovative Research (AcSIR) & CSIR-Indian Institute of Chemical Technology, India)	356
<i>A High Throughput Internet Access Protocol (HTIAP) for Moving Things in Smart Cities</i>	
Arvind Kumar Shah (IEST, Shibpur & Microsoft, India), Sohini Roy (Arizona State University, USA), Abhijit Sharma (National Institute of Technology, Durgapur, India), Uma Bhattacharya (Bengal Engineering & Science University, India)	365
<i>Fault-Tolerant Sensor Using Model Based Simulated Value for Space Environment Simulation Applications</i>	
Kaushik S (Bangalore Institute of Technology, India), Ajay G (Bangalore Institute of Technology, India), Dhanush S (Bangalore Institute of Technology, India), Mahendra S Gowda (Bangalore Institute of Technology, India), Faizuddin Faruqui (ISRO Satellite Center, India)	372
<i>Flow Statistics Based Load Balancing in OpenFlow</i>	
Karamjeet Kaur (AD College Dharamkot, India), Sukhveer Kaur (AD College Dharamkot, India), Vipin Gupta (U-Net Solutions, Moga, India)	378
<i>Checkpoint Based Multi-Version Concurrency Control Mechanism for Remote Healthcare System</i>	
Ammlan Ghosh (University of Calcutta, India), Rituparna Chaki (University of Calcutta, India), Nabendu Chaki (University of Calcutta, India)	382
<i>Tree Based Tracking Target in Wireless Sensor Network</i>	
Suman Bhowmik (College of Engineering & Management, Kolaghat, India), Sushovan Das (College of Engineering and Management, Kolaghat, India), Chandan Giri (Bengal Engineering & Science University, Shibpur, India)	390
<i>Energy Aware Routing in WSN for Pest Detection in Coffee Plantation</i>	
Roshan Zameer Ahmed (Reva Institute of Technology and Management, India), Rajashekhar Biradar (Reva University, India)	398
<i>Security Threats in Vehicular Ad Hoc Networks</i>	
Ahmed Shoeb Al Hasan (Bangladesh University of Engineering & Technology, Dhaka, Bangladesh), Md Shohrab Hossain (Bangladesh University of Engineering and Technology, Bangladesh), Mohammed Atiquzzaman (University of Oklahoma, USA)	404
<i>Online Reviews: Determining the Perceived Quality of Information</i>	
Gobinath J (Amrita School of Business, Coimbatore, India, India), Deepak Gupta (Amrita School of Business & ASB, India)	412

ICACCI-05: Embedded Systems/Computer Architecture and VLSI/Adaptive Systems/ICAIS'16 (Regular Papers)

<i>Load Forecasting in India At Distribution Transformer Considering Economic Dynamics</i> Kumar Padmanabh (Robert Bosch, India).....	417
<i>Comparative Studies on Design of Fractional Order Proportional Integral Differential Controller</i> Rosy Pradhan (Veer Surendra Sai University of Technology, Burla, India), Pratyush Patra (Veer Surendra Sai University of Technology, Burla, India), Bibhuti Pati (Veer Surendra Sai University of Technology, India).....	424
<i>Finite Element Analysis of Composite Overwrapped Pressure Vessel for Hydrogen Storage</i> Atul S Takalkar (VIT University, India), Shantanu S Bhat (KIT's College of Engineering, India), Shubham S Chavan (KIT's College of Engineering, India), Swapnil B Kamble (KIT's College of Engineering, India), Arpit P Kulkarni (KIT's College of Engineering, India), Sandesh B Sangale (KIT's College of Engineering, India).....	430
<i>A Novel Design Microstage Based on Piezoelectric Actuation</i> Kiran Junagal (Rajasthan Technical University Kota Rajasthan India, India), R. s. Meena (UCE, KOTA, India).....	437
<i>Fixed Point Implementation of Trigonometric Function Using Taylor's Series and Error Characterization</i> Sunil Prasad (National Aerospace Laboratories, India), C. m. Ananda (National Aerospace Laboratory, India), Rekha S (PES Institute of Technology, Bangalore, India), Somesh Nandi (PES Institute of Technology, India).....	442
<i>Performance Comparison of Proximal Methods for Regression with Nonsmooth Regularizers on Real Datasets</i> Mridula Verma (Indian Institute of Technology, BHU), Varanasi, India), K K Shukla (IIT-BHU, India).....	447
<i>A Fast Universal Search by Equivalent Program Pruning</i> Swarna Kamal Paul (Tata Consultancy Services & Jadavpur University, India), Parama Bhaumik (Jadavpur University, India).....	454
<i>Circular Polarization in Transparent Circular Patch with Defected Structure</i> Nurul Gondane (SPPU PUNE, India), Jayashree Shinde (SAE KONDHWA PUNE, India), Pratap Shinde (SAE KONDHWA PUNE, India).....	461
<i>Multi User Interference Characterization of Multiband OFDM UWB System in the Presence of Log-normal Fading Channels</i> Sai Krishna Kondoju (National Institute of Technology Warangal, India), Venkata Mani Vakamulla (National Institute of Technology Warangal, India).....	466
<i>A Novel Decoding Technique for Least-Squares Notching Precoder in OFDM Cognitive Radio</i> Ravinder Kumar (Indian Institute of Technology Roorkee, India).....	472
<i>Hiper-Ping: Data Plane Based High Performance Packet Generation Bypassing Kernel on X86 Based Commodity Systems</i> Aravind Ajayan (Amrita University, India), Prabakaran Poornachandran (Amrita Vishwa Vidyapeetham, Amrita University, India), Manu Krishnan (Amrita Vishwa Vidyapeetham, India), Soumajit Pal (Amrita University, India).....	478
<i>Improved Set-Membership Partial-Update Pseudo Affine Projection Algorithm</i> Felix Albu (Valahia University of Targoviste, Romania), Paulo Diniz (Universidade Federal do Rio de Janeiro, Brazil).....	484

<i>Analytical Study on the Effect of Dimension and Position of Slot for the Designing of Ultra Wide Band (UWB) Microstrip Antenna</i> Ranjan Mishra (University of Petroleum and Energy Studies Dehradun, India), Raj Gaurav Mishra (University of Petroleum and Energy Studies, Dehradun, India), Piyush Kuchhal (University of Petroleum and Energy Studies, Dehradun, India).....	488
---	-----

ICACCI-06: NLP'16/Natural Language Processing and Machine Translation (Regular Papers)

<i>Detection of a New Class in a Huge Corpus of Text Documents Through Semi-Supervised Learning</i> Guru D S (Mysore University, India), Mahamad Suhil (University of Mysore, India), Harsha S Gowda (University of Mysore, India), Lavanya Narayana Raju (University of Mysore, India).....	494
<i>Analysis of Polysemy Words in Kannada Sentences Based on Parts of Speech</i> Rahul Rao (MS Ramaiah Institute of Technology, India), Jagadish S Kallimani (MS Ramaiah Institute of Technology, India).....	500
<i>ResearchAssist: Analyzing Author Interests</i> Debarati Das (PES Institute of Technology, India), Lisa Thomas (PES Institute of Technology, India), Kavi Mahesh (PES Institute of Technology, India).....	505
<i>Multiclass Classification and Class Based Sentiment Analysis for Hindi Language</i> Sumitra Purushottam Pundlik (MIT College Of Engineering Kothrud Pune, India), Prachi Kasbekar (MIT College of Engineering, India), Gajanan Gaikwad (MIT College of Engineering, India), Prasad Dasare (MIT College of Engineering, India), Akshay Gawade (MIT College of Engineering, India), Purushottam Pundlik (Design Engineer, India).....	512
<i>Automatic Ranking of Essays Using Structural and Semantic Features</i> Sunil Kumar Kopparapu (Tata Consultancy Services, India), Arijit De (TCS, India).....	519
<i>Sentiment Analysis for Mixed Script Indic Sentences</i> Rupal Bhargava (Birla Institute of Technology & Science, Pilani, Pilani Campus, India), Yashvardhan Sharma (Faculty, CS & IS, BITS-Pilani, India), Shubham Sharma (Birla Institute of Technology and Science, India).....	524
<i>Multi-level Inflection Handling Stemmer Using Iterative Suffix-Stripping for Malayalam Language</i> Balasankar C (Adi Shankara Institute of Engineering and Technology, Kalady, India), Sobha T (MG University, India), Manusankar C (SSV College Valayanchirangara & Mahathma Gandhi University, India).....	530
<i>Coreference Between Subjective Expression and Holder:A Classification Perspective</i> Sunit Bhattacharya (Central University of Rajasthan, India), Dipankar Das (Jadavpur University, India).....	535
<i>A Rule Based Question Generation Framework to Deal with Simple and Complex Sentences</i> Rubel Das (Jadavpur University, India), Antariksha Ray (Jadavpur University, India), Souvik Mondal (Jadavpur University, India), Dipankar Das (Jadavpur University, India).....	542
<i>Rule Based Kannada Agama Sandhi Splitter</i> Shashirekha Hosahalli Lakshmaiah (Mangalore University, India), Vanishree Kasaravalli Suryanarayana (Government First Grade College Shikaripura, India).....	549

ICACCI-07: Fourth International Symposium on Intelligent Informatics (ISI'16) - Regular Papers

<i>Common Threats to Software Quality Predictive Modeling Studies Using Search-based Techniques</i> Ruchika Malhotra (Delhi Technological University, India), Megha Khanna (Delhi Technological University, India)	554
<i>Facial Expression Based Music Player</i> Sushmita Kamble (KLS Gogte Institute of Technology, India), Anandtirth Kulkarni (KLSGIT, India)	561
<i>Clustering using Cuckoo Search Levy Flight</i> Aishwarya Palaiah (PESIT, India), Akshata Prabhu (PESIT, India), Reetika Agrawal (PESIT, India), Natarajan S (VTU, India)	567
<i>The Winner Decision Model of Tic Tac Toe Game by using Multi-Tape Turing Machine</i> Sneha Garg (Government Mahila Engineering College, Ajmer, India), Dalpat Songara (Rajasthan Technical University, India)	573
<i>Application of Transfer Learning in RGB-D object recognition</i> Abhishek Kumar (Vellore Institute of Technology, India), Nithin Shrivatsav Srikanth (National Institute of Technology, Tiruchirappalli, India), Gorthi R K Sai Subrahmanyam (IIST, India), Deepak Mishra (IIST, India)	580
<i>Comparative Study of the Impact of Processor Architecture on Compiler Tuning</i> CH N A B Sankar (University of Hyderabad & ANURAG DRDO, India), Rajeev Wankar (University of Hyderabad, India)	585
<i>Extension of the Multi-Agent Resource Conversion Processes Model: Implementation of Agent Coalitions</i> Konstantin Aksyonov (Ural Federal University, Russia), Eugene Bykov (Ural Federal University, Russia), Olga Aksyonova (Ural Federal University, Russia), Alena Nevolina (Ural Federal University, Russia), Natalia Goncharova (Ural Federal University, Russia)	593
<i>Stroke Based Online Handwritten Gurmukhi Character Recognition</i> Ramandeep Kaur (Thapar University, India), Mandeep Singh (Thapar University, India)	598
<i>Multi-agent planning with Quantitative Capability</i> Satyendra Chouhan (IIT Roorkee, India), Rajdeep Niyogi (Indian Institute of Technology Roorkee, India)	602
<i>Evaluating Applicability of Perturbation Techniques for Privacy Preserving Data Mining by Descriptive Statistics</i> Alpa Shah (Sarvajanic College of Engineering and Technology & Gujarat Technological University, India), Ravi Gulati (Veer Narmad South Gujarat University, India)	607
<i>Cross-Reference EWOD Driving Scheme and Cross- Contamination Aware Net Placement Technique for MEDA Based DMFBs</i> Pampa Howladar (Indian Institute of Engineering Science and Technology, Shibpur, India), Debashri Roy (University of Central Florida, USA), Pranab Roy (Indian Institute of Engineering Science and Technology, Shibpur, India), Hafizur Rahaman (Bengal Engineering and Science University, Shibpur, India)	614
<i>Rule-Based System for Automated Classification of Non-Functional Requirements from Requirement Specifications</i> Prateek Singh (GLA University, India), Deepali Singh (GLA University, India), Ashish Sharma (GLA University, India)	620

<i>Frequency-based similarity measure for Context-Aware Recommender Systems</i>	
Mohammed Wasid (Aligarh Muslim University, India), Vibhor Kant (Jawaharlal Nehru University, India), Rashid Ali (AMU Aligarh, India)	627
<i>Chaotic Hash Function Based Plain-Image Dependent Block Ciphering Technique</i>	
Sahil Wadhwa (Jamia Millia Islamia, India), Musheer Ahmad (Jamia Millia Islamia, New Delhi, India), Harsh Vijay (Jamia Millia Islamia, India)	633
<i>A Biometrics-based Robust and Secure User Authentication Protocol for e-Healthcare Service</i>	
Sandip Roy (Asansol Engineering College, India), Santanu Chatterjee (Research Center Imarat & Defence Research and Development Organization, Hyderabad, India), Samiran Chattopadhyay (Jadavpur University, India), Amit Gupta (DRDO, India)	638
<i>Bridging the Skill Gap Using Vocational Training Simulators: Validating Skill Assessment Metrics</i>	
Aswathi P (AMMACHI Labs, Amrita School of Engineering, Amritapuri, Amrita Vishwa Vidyapeetham, Amrita University, India, India), Amritha Natarajan (AMMACHI Labs, Amrita School of Engineering, Amritapuri, Amrita Vishwa Vidyapeetham, Amrita University, India, India), Namitha K (AMMACHI Labs, Amrita School of Engineering, Amritapuri, Amrita Vishwa Vidyapeetham, Amrita University, India, India), Nagarajan Akshay (AMMACHI Labs, Amrita School of Engineering, Amritapuri, Amrita Vishwa Vidyapeetham, Amrita University, India, India), Balu M Menon (AMMACHI Labs, Amrita School of Engineering, Amritapuri, Amrita Vishwa Vidyapeetham, Amrita University, India, India), Rao R. Bhavani (AMMACHI Labs, Amrita School of Engineering, Amritapuri, Amrita Vishwa Vidyapeetham, Amrita University, India, India)	645

ICACCI-10: Signal/Image/video/speech Processing/Computer Vision/Pattern Recognition (Regular Papers)

<i>Identifying High Quality Jpeg Compressed Images Through Exhaustive Recompression Technique</i>	
Zeeshan Akhtar (ZHCET AMU Aligarh, India), Ekram Khan (Aligarh Muslim University, India)	652
<i>Statistical Textural Feature and Deformable Model Based MR Brain Tumor Segmentation</i>	
Shoab Banday (NIT Srinagar, India), Ajaz H. Mir (National Institute of Technology Srinagar, India)	657
<i>Hardware and Software Implementation of Weather Satellite Imaging Earth Station</i>	
Chinmay Patil (University of Mumbai, India), Tanmay Chavan (University of Mumbai, India), monali nitin Chaudhari (University of Mumbai, India)	664
<i>Head Pose Estimation for Recognizing Face Images Using Collaborative Representation Based Classification</i>	
Srija Chowdhury (Indian Institute of Engineering Science and Technology, Shibpur, India), Jaya Sil (Indian Institute of Engineering Science and Technology, Shibpur, India)	671
<i>Breast Cancer Detection Using Non-invasive Method for Real Time Dataset</i>	
Basavaraj Hiremath (MSRIT and Jain University, India), Prasannakumar S C (RVCE, Bangalore, India), Praneethi K (MSRTH, India)	676

<i>A Novel ECG Data Compression Algorithm Using Best Mother Wavelet Selection</i>	
Amol Motinath Veer (Indian Institute of Technology Patna, India), Chandan Kumar Jha (Indian Institute of Technology Patna, India), Mahesh Kolekar (Indian Institute of Technology Patna, India).....	682
<i>Reconstruction of Surveillance Videos by Non-Iterative Pseudo Inverse Based Recovery Algorithm (NIPIRA): A Subjective Experience</i>	
Florence Gnana Poovathy John (SSN College of Engineering & Anna University, Chennai, India), S Radha (SSN College of Engineering & Anna University, India).....	687
<i>Reinforced Fast Marching Method and Two Level Thresholding Algorithm for Cloud Detection</i>	
Harinder Kaur (Punjabi University Patiala, India), Neelofar Sohi (Punjabi University Patiala, India).....	693
<i>Combining Temporal Interpolation and DCNN for Faster Recognition of Micro-expressions in Video Sequences</i>	
Veena Maya (Manipal Institute Of Technology & Manipal University, India), Radhika M. Pai (Manipal Institute of Technology, India), Manohara Pai (Manipal Institute of Technology & Manipal University, India).....	699
<i>Quantitative Analysis of Break-lock in Monopulse Receiver Phase-Locked Loop Using Noise Jamming Signal</i>	
Harikrishna Paik (V R Siddhartha Engineering College, India), Neti Narasimha Sastry (V R Siddhartha Engineering College, India), SantiPrabha I (J N T K University, India).....	704
<i>Dynamic Sectored Random Projection for Cancelable Iris Template</i>	
P Punithavathi (VIT University Chennai Campus, India), S Geetha (VIT University Chennai Campus, India).....	711
<i>A Fast Algorithm for Optic Disc Segmentation in Fundus Images</i>	
Santhakumar Ramamoorthy (VIT University, India), Elagiri Ramalingam Rajkumar (VIT University, India), Megha Tandur (Visvesvaraiiah Technological University, India), Geetha K s (VTU, RVCE, India), Kumar Rajamani (Robert Bosch Engineering and Business Solutions Limited, India), Girish Haritz (Robert Bosch Engineering and Business Solutions, India).....	716
<i>Undecimated Dual Tree Complex Wavelet Transform Based Face Recognition</i>	
Rajesh D S (Mangalore University, India), B H Shekar (Mangalore University, India).....	720
<i>Multiple Instance Learning for the Determination of Appropriate Images for Fundus Image Algorithms</i>	
Amruthavarshini Talikoti (R. V. College of Engineering, India), Kavya Venkatesan (R V College of Engineering, India), Geetha K s (VTU, RVCE, India), Digvijay Singh (Medanta-The Medicity, India), Kumar Rajamani (Robert Bosch Engineering and Business Solutions Private Limited, India).....	727

ICACCI-11: Artificial Intelligence and Machine Learning/Data Engineering/Biocomputing (Regular Papers)

<i>Enhanced Shuffled Bat Algorithm (EShBAT)</i>	
Hema Banati (University of Delhi & Dyal singh College, India), Reshu Chaudhary (University of Delhi, India).....	731
<i>Exploiting Apache Flink's Iteration Capabilities for Distributed Apriori: Community Detection Problem as an Example</i>	
Sanjay Rathee (Indian Institute of Technology Mandi, Himachal Pradesh, India), Arti Kashyap (IIT-Mandi, India).....	739

<i>Predicting Software Change-Proneness with Code Smells and Class Imbalance Learning</i>	
Arvinder Kaur (Guru Gobind Singh Indraprastha University, India), Kamaldeep Kaur (Guru Gobind Singh Indraprastha University, India), Shilpi Jain (Guru Gobind Singh Indraprastha University Delhi, India)	746
<i>Review of Back-propagation Algorithms for Defect Elimination with Proposed DMASIC Methodology</i>	
Shweta Loonkar (Mukesh Patel School of Technology Management and Engineering, Mumbai, India), Dharendra Mishra (Mukesh Patel School of Technology Management and Engineering, Mumbai, India)	755
<i>Generalized Similarity Measure for Categorical Data Clustering</i>	
Shruti Sharma (Gurukul Institute of Engineering & Technology kota, India)	765
<i>An Empirical Semi-Supervised Machine Learning Approach on Extracting and Ranking Document Level Multi-Word Product Names Using Improved C-value Approach</i>	
Sivashankari R (VIT Univerisity, Vellore, India), Valarmathi B (VIT Uuniversity, Vellore, India)	770
<i>An Adaptive Distributed Approach of a Self Organizing Map Model for Document Clustering Using Ring Topology</i>	
Ajeissh Mukundan (Amrita Vishwa Vidyapeetham, India), Sandhya Harikumar (Amrita Vishwa Vidyapeetham, India)	776
<i>Fast Convergent Biogeography Based Optimization Algorithm</i>	
Priya Sharma (Rajasthan Technical University kota Rajasthan INDIA, India), Harish Sharma (Rajasthan Technical University, Kota, India)	782
<i>Elitism Based Shuffled Frog Leaping Algorithm</i>	
Pragya Sharma (RTU, India)	788
<i>Predicting Rice Crop Yield Using Bayesian Networks</i>	
Niketa Gandhi (University of Mumbai, India), Leisa J Armstrong (Edith Cowan University, Australia), Owaiz Petkar (University of Mumbai, India)	795
<i>Rainfall-Runoff Modeling Using Computational Intelligence Techniques</i>	
Dhananjay Kumar (Central University of South Bihar, Patna, India), Pradhan Sarthi (Central University of South Bihar, Patna, India), Prabhat Ranjan (Central University of South Bihar, India)	800
<i>Distributed Feature Selection Using Vertical Partitioning for High Dimensional Data</i>	
Bakshi Prasad (IIIT-Allahabad, India), Unmesh Bendale (IIIT-Allahabad, India), Sonali Agarwal (Indian Institute of Information Technology, Allahabad, India)	807
<i>Discovering Preservation Pattern From Co-Expression Modules in Progression of HIV-1 Disease: An Eigengene Based Approach</i>	
Sumanta Ray (Aliah University, India), SK MD Mosaddek Hossain (Aliah University, India), Lutfunnesa Khatun (Aliah University, India)	814

ICACCI-12: Security, Trust and Privacy/Steganography (Regular Papers)

<i>Robust distributed Key issuing Protocol for Identity based cryptography</i> Dasari Kalyani (VNRVJIET, India).....	821
<i>Local Binary Pattern Operator Based Steganography in Wavelet Domain</i> Anuradha Singhal (University of Delhi, India), Punam Bedi (University of Delhi, India).....	826
<i>A Practical Identity Based Signcryption Scheme From Bilinear Pairing</i> Arijit Karati (Indian School of Mines, India), G P Biswas (ISM Dhanbad, India).....	832
<i>Improving False Alarm Rate in Intrusion Detection Systems Using Hadoop</i> Mukund Yelahanka Raghuprasad (National Institute of Technology Karnataka, India), Sunil Nayak (National Institute of Technology Karnataka, India), Chandra Sekaran K (National Institute of Technology Karnataka, India).....	837
<i>Cryptographic Turbo Code for Image Transmission Over Mobile Networks</i> Vidya Sawant (NMIMS University & MPSTME, India), Archana Bhise (Mukesh Patel School of Technology Management & Engineering, India).....	844
<i>Performance Measurements for Hypervisors on Embedded ARM Processors</i> Axel Sikora (University of Applied Sciences Offenburg, Germany), Sebouh Toumassian (University of Applied Sciences Offenburg, Germany), Rico Werner (University of Applied Sciences Offenburg, Germany).....	851
<i>A Hybrid Intelligent Security Technique used for Digital Still Image</i> Sudhanshu S. Gonge (Savitribai Phule Pune University & Genba Sopanrao Moze College of Engineering Pune, India), Ashok Anandrao Ghatol (Director Genba Sopanrao Moze College of Engineering Pune, India).....	856
<i>Split First Encryption Next Model for Cotenant Covert Channel Protection</i> Sankarasetty Rama krishna (VYCET, CHIRALA, India), Bokka Padmaja Rani (Jawaharlal Technological university, India).....	866
<i>Image Encryption using Wavelet based Chaotic Neural Network</i> Sushil Kumar (Guru Gobind Singh Indraprastha University, India).....	875
<i>Lightweight Security Framework for IoTs using Identity based Cryptography</i> Sriram Sankaran (Amrita University, India).....	880
<i>Secure Strategic Mail Application with Hardware Device</i> Thirumal kumar Kanakurthi (BEL & BEL, India), Hemanth Kumar Nooka (CRL-BEL, India), Anka rao Ittadi (BEL, India), Akila M (BEL-CRL, India), Bhanusree K (BEL-CRL, India).....	887

ICACCI-13A: Artificial Intelligence and Machine Learning/Data Engineering/Biocomputing (Regular Papers)

Lbest Gbest Artificial Bee Colony Algorithm

Harish Sharma (Rajasthan Technical University, Kota, India), Sonal Sharma (Career Point University, Kota, India), Sandeep Kumar (Jagannath University Jaipur, India).....	893
<i>Designing Automatic Note Transcription System for Hindustani Classical Music</i>	
Prasenjit Dhara (IIT-Kharagpur, India), Pradeep Rengaswamy (IIT Kharagpur, India), K. Sreenivasa Rao (IIT KGP, India).....	899
<i>Simple yet Effective Classification Model for Skewed Text Categorization</i>	
Mahamad Suhil (University of Mysore, India), Guru D S (Mysore University, India), Lavanya Narayana Raju (University of Mysore, India), Harsha S Gowda (University of Mysore, India).....	904
<i>An Improved Fuzzy Based Approach to Impute Missing Values in DNA Microarray Gene Expression Data with Collaborative Filtering</i>	
Sujay Saha (Heritage Institute of Technology, India), Anupam Ghosh (Netaji Subhas Engineering College, India), Saikat Bandopadhyay (Heritage Institute of Technology, India), Kashi Nath Dey (University of Calcutta, India).....	911
<i>Computational Reconstruction of fMRI-BOLD From Neural Activity</i>	
Chaitanya Nutakki (Amrita School of Biotechnology, Amrita Vishwa Vidyapeetham, Amrita University, India), Ahalya Nair (Amrita Vishwa Vidyapeetham, Amrita University, India), Chaitanya Medini (Amrita Vishwa Vidyapeetham (Amrita University), India), Manjusha Nair (Amrita School of Biotechnology, Amrita Vishwa Vidyapeetham, India), Bipin Nair (Amrita Vishwa Vidyapeetham (Amrita University), India), Shyam Diwakar (Amrita Vishwa Vidyapeetham (Amrita University), India).....	917
<i>Computing LFP From Biophysical Models of Neurons and Neural Microcircuits</i>	
Sandeep Bodda (Amrita Vishwa Vidyapeetham, Amrita University, India), Harilal Parasuram (Amrita Vishwa Vidyapeetham (Amrita University), India), Bipin Nair (Amrita Vishwa Vidyapeetham (Amrita University), India), Shyam Diwakar (Amrita Vishwa Vidyapeetham (Amrita University), India).....	922
<i>A Study of Gene Prioritization Algorithms on PPI Networks</i>	
Sinsha KP (Amrita University, India), Bhadrachalam Chitturi (Amrita University, USA).....	927
<i>Identification of Olfactory Receptors Using a Parametric Model</i>	
Pranay Sakhare (Dr B R Ambedkar NIT Jalandhar, India), Rajneesh Rani (Dr B R Ambedkar NIT Jalandhar, India), Ranjeet Kumar Rout (Dr B R Ambedkar NIT Jalandhar, India).....	935
<i>Alignment Free Promoter Sequences Analysis Using Feature Reduced Cumulative Distribution of Motifs</i>	
Kouser K (University of Mysore, India), Lalitha Rangarajan (University of Mysore, India).....	941
<i>Faster Mahalanobis K-Means Clustering for Gaussian Distribution</i>	
Ankita Chokniwal (Gurukul Institute of Engineering and Technology, Kota ,Rajasthan, India), Manoj Singh (Gurukul Institute of Engineering and Technology, India).....	947
<i>Effect of Event Sequence on Intragroup Dynamics: Simulation Using Modified Hopfield Neural Network</i>	
Amita Kapoor (University of Delhi & Shaheed Rajguru College of Applied Sciences for Women, India), Narotam Singh (IMD, Ministry of Earth Sciences, India).....	953

<i>Design and Development of Balance Training Platform and Games for People with Balance Impairments</i>	
Amritha N (AMMACHI Labs, Amrita School of Engineering, Amritapuri, Amrita Vishwa Vidyapeetham, Amrita University, India, India), Mahima M. Menon (AMMACHI Labs, Amrita School of Engineering, Amritapuri, Amrita Vishwa Vidyapeetham, Amrita University, India, India), Namitha K (AMMACHI Labs, Amrita School of Engineering, Amritapuri, Amrita Vishwa Vidyapeetham, Amrita University, India, India), Radhakrishnan Unnikrishnan (AMMACHI Labs, Amrita School of Engineering, Amritapuri, Amrita Vishwa Vidyapeetham, Amrita University, India, India), Harish Mohan (AMMACHI Labs, Amrita School of Engineering, Amritapuri, Amrita Vishwa Vidyapeetham, Amrita University, India, India), Ravi Sankaran (Department of Physical Medicine and Rehabilitation, Amrita Institute of Medical Sciences and Research Center, Kochi, India), Rao R. Bhavani (AMMACHI Labs, Amrita School of Engineering, Amritapuri, Amrita Vishwa Vidyapeetham, Amrita University, India, India)	960
<i>Design & Realization of Multi Mission Data Handling System for Remote Sensing Satellite</i>	
Lalitrushna J Thakar (Indian Space Research Organization, India), Chayan Dutta (ISRO Satellite Centre, India), P s Sura (Indian Space Research Organization, India), S Udupa (ISRO Satellite Centre, India)	967
<i>Effort Estimation of Web-based Applications Using Machine Learning Techniques</i>	
Shashank Mouli Satapathy (Manipal University Jaipur, India), Santanu Kumar Rath (National Institute of Technology (NIT), Rourkela, India)	973

ICACCI-13B: Artificial Intelligence and Machine Learning/Data Engineering/Biocomputing (Regular Papers)

<i>Impact of Dilution of Precision for Position Computation in Indian Regional Navigation Satellite System</i>	
Mehul Desai (Sardar Vallabhbhai National Institute of Technology, Surat, India), Darshna Jagiwala (Sardar Vallabhbhai National Institute of Technology, Surat, India), Shweta Shah (Sardar Vallabhbhai National Institute of Technology, Surat, India)	980
<i>Neuro-Endo-Activity-Tracker: An Automatic Activity Detection Application for Neuro-Endo-Trainer</i>	
Britty Baby (Indian Institute of Technology Delhi, India), Vinkle Srivastav (Indian Institute of Technology Delhi, India), Ramandeep Singh (Indian Institute of Technology, Delhi, India), Ashish Suri (All India Institute of Medical Sciences, India), Subhashis Banerjee (Indian Institute of Technology Delhi, India)	987
<i>An FSM Based Methodology for Interleaved and Concurrent Activity Recognition</i>	
Kavya J (Amrita School of Engineering, Amritapuri, Amrita Vishwa Vidyapeetham, Amrita University, India), Geetha M (Amrita University, Amritapuri, Kollam India Clappana P O, India)	994
<i>Improving the Intelligibility of Dysarthric Speech Towards Enhancing the Effectiveness of Speech Therapy</i>	
Arun Kumar Shanmugam (AMRITA University, India), Santhosh C Kumar (Amrita Vishwa Vidyapeetham, India)	1000
<i>Indian Sign Language Recognition: An Approach Based on Fuzzy-Symbolic Data</i>	
Nagendraswamy H S (University of Mysore, India), BM Chethana Kumara (University of Mysore, India), R Lekha Chinmayi (University of Mysore, India)	1006
<i>Language Identification Using PLDA Based on I-Vector in Noisy Environment</i>	
Manish Rai (Central University of South Bihar, India), Jainath Yadav (IIT Kharagpur, India), K. Sreenivasa Rao (IIT KGP, India),	

Neetish Kumar (Central University of Bihar, India), Md. Shah Fahad (Central University of South Bihar, India).....	1014
<i>Assessing impact of seasonal rainfall on rice crop yield of Rajasthan, India using Association Rule Mining</i>	
Niketa Gandhi (University of Mumbai, India), Leisa J Armstrong (Edith Cowan University, Australia).....	1021
<i>Object Based Schema Oriented Data Storage System for Supporting Heterogeneous Data</i>	
Anindita SarkarMondal (Jadavpur University, India), Samiran Chattopadhyay (Jadavpur University, India), Sarmistha Neogy (Jadavpur University, India), Nandini Mukherjee (Jadavpur University, India).....	1025
<i>HealthAnalytic: A Concept Application for Customizable Visualization and Analysis of Health Informatics Datasets</i>	
Sumit Soman (Center for Development of Advanced Computing, India), Sushil Kumar (Center for Development of Advanced Computing, India), Sujeet Kumar (CDAC, India).....	1033
<i>Performance Prediction and Behavioral Analysis of Student Programming Ability</i>	
Medha Sagar (Indira Gandhi Institute of Technology & Guru Gobind Singh Indraprastha University, India), Arushi Gupta (Indira Gandhi Delhi Technical University for Women, India), Rishabh Kaushal (Indira Gandhi Delhi Technical University for Women, India).....	1039
<i>A Comparative Study of Segment Representation for Biomedical Named Entity Recognition</i>	
Shashirekha Hosahalli Lakshmaiah (Mangalore University, India), Hamada Ali Nayel (Mangalore University & Benha University, India).....	1046
<i>Term-Class-Max-Support (TCMS): A Simple Text Document Categorization Approach Using Term-Class Relevance Measure</i>	
Guru D S (Mysore University, India), Mahamad Suhil (University of Mysore, India).....	1053
<i>A Multi-Cue Information Based Approach to Contour Detection by Utilizing Superpixel Segmentation</i>	
Sandipan Choudhuri (Jadavpur University, India), Nibarani Das (Jadavpur University, India), Swarnendu Ghosh (Jadavpur University, India), Mita Nasipuri (Jadavpur University, India).....	1057

ICACCI-14: Symposium on Advances in Applied Informatics (SAI'16) - Regular Papers

<i>DoS Attack Detection Technique Using Back Propagation Neural Network</i>	
Monika Khandelwal (NIT Jalandhar, India), Deepak Kumar Gupta (National Institute of Technology Jalandhar, India), Pradeepkumar Bhale (ABV-Indian Institute of Information Technology and Management, India).....	1064
<i>Role of Physical Environment (Dinescape Factors Influencing Customers' Revisiting Intention to Restaurants</i>	
Saravanan Mahalingam (Amrita School of Business, Coimbatore Amrita Vishwa Vidyapeetham Amrita University India, India), Bhawana Jain (Amrita School of Business, Coimbatore Amrita Vishwa Vidyapeetham Amrita University India, India), Mridula Sahay (Amrita Vishwa Vidyapeetham University, India).....	1069
<i>Learning Curve Analysis for Virtual Laboratory Experimentation</i>	
Saneesh F (Amrita Vishwa Vidyapeetham, India), Vysakh Kanikkolil (Amrita Vishwa Vidyapeetham, India), Krishnashree Achuthan (Amrita School of Engineering, India).....	1073
<i>Interactive Learning System for the Hearing Impaired and the Vocally Challenged</i>	

Hrishikesh N (Amrita School of Engineering, India), Jyothisha J Nair (Amrita University, India)	1079
<i>Auto-annotation of Tomato Images Based on Ripeness and Firmness Classification for Multimodal Retrieval</i>	
Priti Sehgal (Keshav College, University of Delhi, India), Nidhi Goel (University of Delhi, India)	1084
<i>Fatigue Detection and Estimation Using Auto-Regression Analysis in EEG</i>	
Abhinandan Jain (Aligarh Muslim University, India), Baqar Abbas (Aligarh Muslim University, India), Omar Farooq (Aligarh Muslim University, Aligarh, India), Shashank Garg (Aligarh Muslim University, India)	1092
<i>An Enhancement in Automatic Seed Selection in Breast Cancer Ultrasound Images Using Texture Features</i>	
Lipismita Panigrahi (NIT RAIPUR, Chhattisgarh, India)	1096
<i>Intelligent Information Retrieval for Tsunami Detection Using Wireless Sensor Nodes</i>	
Deepali Virmani (BPIT, GGSIPU & BPIT, IP University, Delhi, India), Nikita Jain (Bhagwan Parshuram Institute of Technology, GGSIPU, India)	1103
<i>Fine Grained Key Computation Scheme for Secure Data Sharing in Cloud</i>	
Deepa Maria Polson (College of Engineering, tm, India), Sabitha S (College of Engineering, Trivandrum, India), MS Rajasree (IITMK, India)	1110
<i>QoE assesment of MPEG-DASH in polimedia e-learning System</i>	
Laura Garcia (Universidad Politecnica de Valencia, Spain, Spain), Jaime Lloret (Universidad Politecnica de Valencia, Spain, Spain), Carlos Turro (Universidad Politecnica de Valencia, Spain, Spain), Miran Taha (Universidad Politecnica de Valencia, Spain, Spain)	1117
<i>Ubiquitous Energy Efficient Aquaculture Management System</i>	
Sangeetha Rajesh (K. J. Somaiya Institute of Management Studies and Research, India)	1124
<i>Empirical Mode Decomposition vs. Variational Mode Decomposition on ECG Signal Processing: A Comparative Study</i>	
Uday Maji (Haldia Instiyute of Technology, India)	1129
<i>Analysis of Echo Cancellation Techniques in Multi-Perspective Smart Classroom</i>	
Ramesh Guntha (Amrita Center for Wireless Networks and Applications, Amrita Vishwa Vidyapeetham University, India), Balaji Hariharan (Amrita University, India), Venkat Rangan (Amrita University, India)	1135
<i>Exploring Concept of QR Code and Its Benefits in Digital Education System</i>	
Saroj Goyal (MACERC, India), Surendra Yadav (MACERC JAIPUR, India), Manish Mathuria (Rajasthan Technical University, India)	1141

ICACCI-19: Symposium on Intelligent Informatics (ISI'16)/Symposium on Advances in Applied Informatics (SAI'16)

<i>Effective Discriminant Function for Intrusion Detection Using SVM</i>	
Ramasani Ravinder Reddy (Osmania University, India)	1148
<i>Environmental Awareness Around Vehicle Using Ultrasonic Sensors</i>	

Priya Hosur (B. V. Bhoomraddi College Of Engineering and Technology, India), Rajashekar Basavaraj Shettar (Vishweswaraya technological University, Belgaum.Karnataka State, India), Milind Potdar (KPIT, India).....	1154
<i>Speech Signal Analysis for the Estimation of Heart Rates Under Different Emotional States</i>	
Alex Pappachen James (Nazarbayev University & Enview R&D Labs, Kazakhstan), Aibek Ryskaliyev (Nazarbayev University, Kazakhstan), Sanzhar Askaruly (Nazarbayev University, Kazakhstan).....	1160
<i>Exploratory Test Oracle using Multi-Layer Perceptron Neural Network</i>	
Wellington Makondo (Harare Institute of Technology, Zimbabwe), Raghava Srinivasa Nallanthighal (DTU, Delhi, India), Innocent Mapanga (Harare Institute of Technology, Zimbabwe), Prudence Kadebu (Harare Institute of Technology, Zimbabwe).....	1166
<i>Analysis of Compressive Sensing For Non Stationary Music Signal</i>	
Vivek Upadhyay (MNIT, India), Amit Joshi (Malviya National Institute of Technology, India).....	1172
<i>Lab VIEW Event handling using EPICS PV for ICRH DAC SOFTWARE</i>	
Ramesh Joshi (Institute for Plasma Research, India), HM Jadav (Institute for Plasma Research, India), Aniruddh Mali (Gujarat Technological University, India), S Kulkarni (Institute for Plasma Research, India).....	1177
<i>FPGA based Hardware Implementation of Automatic Vehicle License Plate Detection System</i>	
Surbhi Chhabra (The LNM Institute of Information Technology, Jaipur, India), Himanshu Jain (The LNM Institute of Information Technology, Jaipur, India), Sandeep Saini (The LNM Institute of Information Technology, India).....	1181
<i>An Efficient Method of Detecting Exudate in Diabetic Retinopathy:Using Texture Edge Features</i>	
Priyadarshini M Patil (BVB College of Engineering & Technology, India), Pooja Shettar (BVB College of Engineering, Hubli, India), Prashant Narayankar (BVBhoomaraddi College of Engineering and Technology, India), Mayur Patil (Tesco Bengaluru, India).....	1188
<i>The Relationship between IT Adoption, IS Success and Project Success</i>	
Thanh D. Nguyen (Banking University of Ho Chi Minh City, Vietnam), Tuan M. Nguyen (HCMC University of Technology, Vietnam), Thi H. Cao (Saigon Technology University, Vietnam).....	1192
<i>Efficient User Assignment in Crowd Sourcing Applications</i>	
Akash Yadav (Indian Institute of Technology, Patna, India), Ashok Singh Sairam (Indian Institute of Technology Patna, India), Rituraj Singh (IIT Patna, India).....	1199
<i>Image Steganography Method Using K-Means Clustering and Encryption Techniques</i>	
Bhagya Pillai (Amrita Vishwa Vidyapeetham, India), Padmamala Sriram (Amrita University, India), Pooja Rao (Amrita Vishwa Vidyapeetham, Afghanistan), Mundra Mounika (Amrita Viswa Vidyapeetham, India).....	1206
<i>CMAC: Collaborative Multi Agent Computing for Multi Perspective Multi Screen Immersive e-Learning System</i>	
Ramesh Guntha (Amrita Center for Wireless Networks and Applications, Amrita Vishwa Vidyapeetham University, India), Balaji Hariharan (Amrita University, India), Venkat Rangan (Amrita University, India).....	1212
<i>Classification of Text Documents Using Association Rule Mining with Critical Relative Support Based Pruning</i>	
Saurabh Mathur (VIT University, India), Karthik Prabhakar (VIT University, India), Chandrasekhar Uddagiri (H. No 6 2nd cross C Sector V G Rao Nagar Katpadi Vellore TN & VIT University, Vellore, India).....	1219

ICACCI-22: Symposium on Emerging Topics in Circuits and Systems (SET-CAS'16)

<i>Sparse Channel Estimation Using Orthogonal Matching Pursuit Algorithm for SCM-OFDM System</i> Rashmi N (BMS Institute of Technology and Management, India), Mrinal Sarvagya (Reva Institute of Technology and Management, India).....	1224
<i>Low- Power and High Performance Clocked Regenerative Comparator At 90nm CMOS Technology</i> Shweta Gupta (Chandigarh University Gharuan Punjab, India).....	1228
<i>Design and Implementation of Hybrid 4-bit Flash ADC</i> Kriti Thakur (Chandigarh University, India).....	1233
<i>TFET Simulation Using Matlab and Sentarous TCAD</i> Rockey Bhardwaj (Chandigarh University, India), Gurinderpal Singh (Chandigarh University, Punjab, India).....	1238
<i>Common Mode Implications of a Dynamic Latched Comparator</i> Anurag Sharma (Chandigarh University, Punjab, India), Gurinderpal Singh (Chandigarh University, Punjab, India).....	1245
<i>A Novel Design of Micro-gripper with Enhanced Displacement</i> Vijay Rundla (Rajasthan Technical University, India), Ajay Khunteta (Rajasthan Technical University & Kota Rajasthan India, India).....	1250
<i>Performance Analysis of MANET Routing Protocols in Smart City Message Passing</i> Elizabeth Jacob (Amrita Vishwa Vidyapeetham, Amrita University, India), Sivraj P (Amrita Vishwa Vidyapeetham, Amrita University & Amrita School of Engineering, India).....	1255
<i>Design and Analysis of Cross-Fed Rectangular Array Antenna; an X-Band Microstrip Array Antenna, Operating At 11 GHz</i> Nitin M Varghese (Karunya University, India), Shweta Vincent (Manipal University, India), Om Kumar (Manipal University & Manipal Institute of Technology, India).....	1261
<i>Built in Self-Test Scheme for SRAM Memories</i> Abhinav Sharma (VIT University, India), Ravi V. (VIT University, India).....	1266

ICACCI-25: Symposium on Emerging Topics in Computing and Communications (SETCAC'16)/Symposium on Signal Processing for Wireless and Multimedia Communications (SPWMC'16)

<i>A Novel Method for Resource Discovery From a Range Based Request in a P2P Network</i> Krishna Prasad (Amrita Vishwavidyapeetham University, India), G. p. Sajeew (Amrita University & Govt Engineering College, India).....	1271
<i>On the Selection of Mobility Optimised Routing Protocol for City Scenario using Multi Interface Car in VANET</i>	

Kanu Priya (Guru Nanak Dev University, India)	1277
<i>An Authentication Framework for Securing Virtual Machine Migration</i>	
Santosh Kumar Majhi (Veer Surendra Sai University of Technology, India), Sunil Dhal (Sri Sri University, Cuttack, India)	1283
<i>Decision Support System for Diagnosis and Prediction of CRF Using Random Subspace Classification</i>	
Ani R (Amrita School of Engineering, India), Greeshma Sasi (Amrita School of Engineering, India), Resmi Sankar U (Amrita School of Engineering, India), O s Deepa (Amrita School of Engineering, India)	1287
<i>A Random Forest Approach for Rating-based Recommender System</i>	
Ajesh A (Amrita School of Engineering, India), Jijin PS (Amrita School of Engineering, India), Jayashree Nair (Amrita School of Engineering, India)	1293
<i>Attribute Reduction Based Anomaly Detection Scheme by Clustering Dependent Oversampling PCA</i>	
Asha Ashok (Amrita Vishwa Vidyapeetham, India), Smitha S (Amrita School of Engineering, India), Kavya Krishna M h (Amrita School of Engineering, India)	1298
<i>Challenge- Response Generation Using RO-PUF with Reduced Hardware</i>	
Abhishek Kumar (Lovely Professional University, India)	1305
<i>Multiuser Detection over Generalized-K Fading Channels using Two-Stage Initialized Teaching Learning Based Optimization</i>	
Lakshmi Manasa Gondela (University College of Engineering Kakinada, India), Pamula Vinay Kumar (University College of Engineering Kakinada & Jawaharlal Nehru Technological University Kakinada, India), Tipparti Anil Kumar (Department of Electronics and Communication Engineering SVS Group of Institutions Hanamkonda, India 506015, India)	1309
<i>MSVM-based Classifier for Cardiac Arrhythmia Detection</i>	
Nasreen Sultana (Bhoj Reddy Engineering College for Women & Vinay Nagar, Santhosh Nagar Cross Roads, Saidabad, Hyderabad, India), Yedukondalu Kamatham (Bhoj Reddy Engineering College for Women & Vinay Nagar, Santhosh Nagar Cross Roads, Saidabad, Hyderabad, India)	1314
<i>An approach to localize the blind node and optimizing parameters by using PSO</i>	
Marisha Sohar (Chandigarh University, Mohali, India)	1319
<i>Reduce the effect of vignetting on MIMO optical wireless system by reducing BER of channel</i>	
Pallavi Nag (Chandigarh University, Mohali, India)	1324
<i>A New Feature Extraction Method for Identification of Affected Regions and Diagnosis of Cognitive Disorders</i>	
Vinith Rejathlal (NITC, India), Sarthaj K (National Institute of Technology Calicut, India), Lijiya A (NIT Calicut, India), V Govindan (NIT Calicut, India)	1329
<i>Selection of Routing Protocols for Advanced Metering Infrastructure</i>	
Sree Lekshmi S (Amrita Vishwa Vidyapeetham, Amrita University, India), Sivraj P (Amrita Vishwa Vidyapeetham, Amrita University & Amrita School of Engineering, India), Sasi K Kottayil (Amrita Vishwa Vidyapeetham, India)	1335
<i>Comparative Study of two Pseudo Chaotic Number Generators for Securing the IoT</i>	
Ons Jallouli (University of Nantes, France), Mohammed Abutaha (University of Nantes, France), Safwan El Assad (École Polytechnique de l'Université de Nantes & IETR Laboratory, France), Maryline Chetto (Université de Nantes & IRCCyN Lab, France), Audrey Queudet (University of Nantes, France), Olivier Deforges (IETR / INSA Rennes, France)	1340

ICACCI-16: Fourth International Symposium on Women in Computing and Informatics (WCI-2016) - Regular Papers

Diffusion Models and Approaches for Influence Maximization in Social Networks

Tejaswi V (NITK, Suratkal, India), Pv Bindu (India & National Institute Technology, Karnataka, India), Santhi Thilagam P. (National Institute of Technology Karnataka & Suratkal, India)	1345
<i>How Social Media Can Contribute During Disaster Events?</i>	
Neha Pandey (People's Education Society Institute of Technology, India), Natarajan S (VTU, India)	1352
<i>A Preemptive Hybrid Ant Particle Optimization (HAPO-P) Algorithm for Smart Transportation</i>	
Vinita Jindal (University of Delhi, India), Vishwaraj Sharma (University of Delhi, India), Punam Bedi (University of Delhi, India)	1357
<i>LASER: A Novel Hybrid Peer to Peer Network Traffic Classification Technique</i>	
G. p. Sajeev (Amrita University & Govt Engineering College, India), Lekshmi Nair (Amrita University, India)	1364
<i>Preventing Packet Dropping Attack on AODV Based Routing in Mobile Ad-Hoc MANET</i>	
Neema Soliyal (G B Pant Engineering College Ghurdauri Pauri Uttarakhand, India), Harvindra Bhadauria (Uttarakhand Technical University, India)	1371
<i>Traffic Analysis for Smart Grid Networks Using Markov Chains with Autocorrelation Function Settings</i>	
Christiane Borges Santos (Instituto Federal de Goiás, Brazil), Fabio da Silva Marques (Instituto Federal de Educação, Ciência e Tecnologia de Goiás, Brazil), Sérgio Araújo (UFG, Brazil), Joao Batista Pereira (Instituto Federal de Goias, Brazil)	1376
<i>Parallel Context Aware Recommender System Using GPU and JCUDA</i>	
Richa Singh (University of Delhi, India), Punam Bedi (University of Delhi, India)	1383
<i>Effective Web Personalization System Based on Time and Semantic Relatedness</i>	
G. p. Sajeev (Amrita University & Govt Engineering College, India), Ramya P t (Amrita School of Engineering, India)	1390
<i>Sequencing of Refactoring Techniques by Greedy Algorithm for Maximizing Maintainability</i>	
Sandhya Tarwani (Guru Gobind Singh Indraprastha University, India), Anuradha Chug (Guru Gobind Singh Indraprastha University, India)	1397
<i>ELM Variants Comparison on Applications of Time Series Data Forecasting</i>	
Sachin Kumar (University of Delhi, India), Shobha Rai (University of Delhi, India), Saibal K. Pal (DRDO, India), Ram Pal Singh (DDUC, Delhi University, India)	1404
<i>Comparative Analysis of Concentration Control for Nonlinear Continuous Stirred Tank Reactor</i>	
Dipti Tamboli (SVERI's College of Engineering, Pandharpurr, India)	1410
<i>A Novel and Secure Methodology for Keyless Ignition and Controlling an Automobile Using Air Gestures</i>	
Sudhir Rao Rupanagudi (WorldServe Education, India), Varsha Bhat (WorldServe Education, India), Supriya R (Atria Institute of Technology, India), Riya Dubey (Atria Institute of Technology, India), Suma Sukumar (Atria Institute of Technology, India), Srabanti	

Karmarkar (Atria Institute of Technology, India), Amulya K (BNMIT, India), Ankita Raman (BNMIT, India), Devika Indrani (BNMIT, India), Abhiram Srisai (BNMIT, India), Mahathy Rajagopalan (R V College of Engineering, India), Vaishnavi Venkatesh (R V College of Engineering, India), Nupur Jain (R V College of Engineering, India)	1416
--	------

ICACCI-24: Symposium on Women in Computing and Informatics (WCI-2016) - Short Papers

<i>Detection of Fuzzy Duplicates in High Dimensional Datasets</i>	
Raksha N (Visvesvaraya Technological University, India), Raj Alankar (Visvesvaraya Technological University, India)	1423
<i>Public Health Allergy Surveillance Using Micro-blogs</i>	
Kruti Nargund (VTU, India), Natarajan S (VTU, India)	1429
<i>Survey on Meta Heuristic Optimization Techniques in Cloud Computing</i>	
Shishira Sr (National Institute of Technology Karnataka & National Institute of Technology Karnataka, India), Kandasamy A (National Institute of Technology Karnataka, India), Chandrasekaran K (National Institute of Technology Karnataka, India)	1434
<i>OSEECH: Optimize Scalable Energy Efficient Clustering Hierarchy Protocol in Wireless Sensor Networks</i>	
Shiv Singh (Gbpec Pauri, India), Bhumika Gupta (Gbpec Pauri, India)	1441
<i>Energy Efficient Protocol for Cognitive Sensor Networks Based on Particle Swarm Optimization</i>	
Anuja Rawat (G. B. P. E. C. Pauri Garhwal, India), Shashi Verma (G. B. P. E. C. Pauri Garhwal, India)	1447

ICACCI-27: Symposium on Intelligent Informatics (ISI'16)/Symposium on Advances in Applied Informatics (SAI'16)

<i>Image Convolution Optimization Using Sparse Matrix Vector Multiplication Technique</i>	
Bipin B (Amrita University, India), Jyothisha J Nair (Amrita University, India)	1453
<i>An Implementation and Performance Evaluation of An Improved Chaotic Image Encryption Approach</i>	
Gaytri Bakshi (KITM, India), Shelza Suri (Banasthali University, India), Ritu Vijay (Banasthali University, India)	1458
<i>Design of a GPS-Enabled Multi-modal Multi-controlled Intelligent Spybot</i>	
Anushka Gupta (Jaypee University of Information Technology, Wagnaghat, Solan, India), Shailesh Tanwar (Mukesh Patel School of Technology Management and Engineering, NMIMS, Mumbai, Maharashtra, India), Vishvander Singh (Army Institute of Technology, Pune, Maharashtra, India), Lavanya Matta (Indian Institute of Information Technology, Chittoor, Sricity, A. P., India), Vinay Kumar Mittal (Indian Institute of Technology Chittoor, Sri City, India)	1464
<i>Evaluation of Mobile Learning in Workplace Training</i>	
Muneer Dar (National Institute of Electronics & Information Technology, Srinagar, India), Sameer Ahmad Bhat (Preparatory Year King Saud University, Saudi Arabia)	1468
<i>Constraint Based Recipe Recommendation Using Forward Checking Algorithm</i>	
Kirti Pawar (MUMBAI & RAIT, India)	1474

<i>Transition of Indian ICT Processes to Smart E-Services - Way Ahead</i>	
Arpit Jain Singhai (National Informatics Centre, India), Danish Faizan (NIC-INDIA, India)	1479
<i>The Impact of Globalization on the Perception of Beauty Among South Indian Women</i>	
Rajiv Prasad (Amrita Vishwa Vidyapeetham University & Amrita School of Business, India), Lakshmi Unnikrishnan (Amrita Vishwa Vidyapeetham University, India)	1487
<i>Effect of Hofstede's Dimensions on Skin Care Advertising At the Micro Level A Content Analysis of Olay's Indian and US Digital Ads</i>	
Parvathy Saseendran Nair (Amrita Vishwavidyapeetam, India), Chitra Ramakrishnan (Amrita Vishwa Vidyapeetham, India)	1496
<i>An approach towards quality assessment of turmeric rhizomes using surface thermal profiles</i>	
Navreet Saini (CSIR-Central Scientific Instrument Organisation, India), Amitava Das (CSIO, India)	1503
<i>Automatic classification of turmeric rhizomes using the external morphological characteristics</i>	
Arshpreet Kaur (Punjabi University, India), Navreet Saini (Central scientific Instruments Organisation, India), Ranjit Kaur (Punjabi University, India), Amitava Das (CSIO, India)	1507
<i>Identification of Causal Relationships Among Clinical Variables for Cancer Diagnosis Using Multi-Tenancy</i>	
Marasanapallekalle Krishna (Manipal Institute of Technology, India), Sanjay Singh (Manipal Institute of Technology, India)	1511
<i>An Empirical Evaluation of Local Descriptors in Object Recognition</i>	
Ritu Rani (Guru Gobind Singh Indraprastha University New Delhi, India), Ravinder Kumar (HMR Institute of Technology & Management & GGS IPU, India), Amit Prakash Singh (Guru Gobind Singh Indraprastha University, India)	1517

ICACCI-28: Fourth International Symposium on Women in Computing and Informatics (WCI-2016) - Regular Papers

<i>Video Clip Retrieval Using Local Phase Quantization</i>	
K P Uma (Mangalore University, India), B H Shekar (Mangalore University, India), Raghurama Holla, K (Mangalore University, India)	1522
<i>Bioinspired Memory Model for HTM Face Recognition</i>	
Alex Pappachen James (Nazarbayev University & Enview R&D Labs, Kazakhstan), Olga Krestinskaya (Nazarbayev University, Kazakhstan)	1528
<i>2L-DWTS - Steganography Technique Based on Second Level DWT</i>	
Punam Bedi (University of Delhi, India), Veenu Bhasin (University of Delhi, India), Tarun Yadav (University of Delhi, India)	1533
<i>Clustering of Words Using Dictionary-Learnt Word Representations</i>	
Remya Menon (Amrita Vishwa Vidyapeetham, India), Gargi S (Amrita School of Engineering, India), Samili S (Amrita School of Engineering, India)	1539
<i>Harnessing the Discriminatory Strength of Dictionaries</i>	
Remya Menon (Amrita Vishwa Vidyapeetham, India), Neethu V Kini (Amrita School Of Engineering, India), Athira Krishnan G (Amrita School Of Engineering, India)	1546

<i>Detection of Suspicious Lesions in Mammogram Using Fuzzy C-Means Algorithm</i>	
Mukesh Kumar (Gbpec Pauri, India), Upendra Bhatt (Gbpec, India), V Thakkar (Gbpec Pauri, India), Neema Soliyal (G B Pant Engineering College Ghurdauri Pauri Uttarakhand, India)	1553
<i>Object Detection Using Binocular Vision</i>	
Neethu S (Amrita Vishwa Vidyapeetham, India)	1558
<i>An Automated Design of Pin-Constrained Digital Microfluidic Biochip on MEDA Architecture</i>	
Pampa Howladar (Indian Institute of Engineering Science and Technology, Shibpur, India), Pranab Roy (Indian Institute of Engineering Science and Technology, Shibpur, India), Hafizur Rahaman (Bengal Engineering and Science University, Shibpur, India)	1565
<i>Detection and Prediction of Osteoporosis Using Impulse Response Technique and Artificial Neural Network</i>	
Tejaswini E (Amrita Vishwa Vidyapeetham, India), Vaishnavi P (Amrita Vishwa Vidyapeetham, India), Sunitha R (Amrita Vishwa Vidyapeetham, India)	1571
<i>An Automated Tool for Generating Change Report From Open-Source Software</i>	
Ruchika Malhotra (Delhi Technological University, India), Ankita Bansal (Delhi Technological University, India), Sourabh Jajoria (Netaji Subhas Insitute of Technology, India)	1576

ICACCI-17: Sensor Networks, MANETs and VANETs/Distributed Systems (Short Papers)

<i>Joint Routing, Rate Adaptation And Power Control for Multi-Radio Wireless Mesh Networks</i>	
Mohammed Moin Mulla (KLE Technological University, Hubli, Karnataka, India), Narayan D. G. (BVB College of Engineering and Technology, Hubli, Karnataka, India)	1583
<i>Song Year Prediction Using Apache Spark</i>	
Prakhar Mishra (The LNM Institute Of Information Technology, India), Ratika Garg (The LNM Institute Of Information Technology, India), Akshat Kumar (The LNM Institute Of Information Technology, India), Arpan Gupta (The LNM Institute of Information Technology, India), Praveen Kumar (GRIET, India)	1590
<i>Implementation of a Web-based Programming Tool for Distributed, Connected Arduino Systems</i>	
Manoj Nair (Amrita University, Amrita Vishwa Vidyapeetham, India), Jishnu R (Amrita University, Amrita Vishwa Vidyapeetham, India), Rakesh K M (Amrita University, Amrita Vishwa Vidyapeetham, India), Anand Ramachandran (Amrita University, India)	1595
<i>Ensemble Learning for Network Data Stream Classification Using Similarity and Online Genetic Algorithm Classifiers</i>	
Arun Manicka Raja M (Anna University, Chennai, India), Swamynathan S (Anna University, India)	1601
<i>Rationale Behind The Virtual Sensors and Their Applications</i>	
Atrayee Gupta (Jadavpur University, India), Nandini Mukherjee (Jadavpur University, India)	1608
<i>A Realistic Approach for Representing and Scheduling Workflows in Cloud Computing Environment</i>	
Karupiah Kanagaraj (MEPCO Schlenk Engineering College, India), S Swamynathan (Anna University, India)	1615
<i>Secrecy Performance of a Dual Hop Cognitive Relay Network with an Energy Harvesting Relay</i>	

Siddharth Raghuwanshi (NIT Durgapur, India), Pranabesh Maji (National Institute of Technology, Durgapur, India), Sanjay Dhar Roy (National Institute of Technology Durgapur, India), Sumit Kundu (National Institute of Technology, Durgapur, India).....	1622
<i>Vehicular Traffic Analysis From Social Media Data</i>	
Himanshu Shekhar (B. V. B. College of Engineering and Technology, India), Shankar Setty (B. V. Bhoomaraddi College of Engineering & Technology, India), Uma Mudenagudi (B. V Bhoomaraddi College of Engineering and Technology, Hubli, India).....	1628
<i>Work in Progress: A Proposal for a Hotspot Metric to Extend the Lifetime in Wireless Sensor Network</i>	
Mayada Mustafa (University Putra Malaysia, Malaysia), Borhanuddin Mali (Faculty of Engineering & Universiti Putra Malaysia, Malaysia), Shaiful Hashim (UPM, Malaysia), Mohd. Fadlee A. Rasid (Universiti Putra Malaysia, Malaysia).....	1635
<i>Finding Minimum Node Density for Energy-efficient In-hop Cooperative Relaying in Industrial WSNs</i>	
Debdeep Saha (RCCIIT, India), Somprakash Bandyopadhyay (Indian Institute of Management Calcutta, India).....	1640
<i>Developing and Validating Virtualized Transactional Application of Educational Institutes Using InFraMegh</i>	
Indu Arora (Panjab University, Chandigarh, India), Anu Gupta (Panjab University, India).....	1647
<i>An Approach to Signaling Cost Reduction in Proxy MIPv6 for Mobility Management</i>	
Nitul Dutta (MEF Group of Institutions, Rajkot, India), Zdzislaw Polkowski (The Lower Silesian University of Entrep and Tech, Poland), Corina Savulescu (University of Pitesti, Romania), Sunil Pathak (JK Lakshmi Pat University Jaipur, India).....	1654
<i>Self Power Analysing Energy Efficient Protocol (SPAEEP): An Adaptive approach</i>	
Nitin Palan (University of Poona, India), Balaji Barbadekar (Kolhapur University, India), Suhas Patil (K. B. P. College of Engineering & Polytechnic, India).....	1661
<i>A Routing Load Balanced Trajectory Design for Mobile Sink in Wireless Sensor Networks</i>	
Amar Kaswan (Indian School of Mines, India), Kumar Nitesh (Indian School of Mines, India), Prasanta Kumar Jana (Indian School of Mines, India).....	1669

ICACCI-18: Security Informatics/SAI'16 (Short Papers)

<i>Extended-HyperWall:Hardware Support for Rollback Secure Virtualization</i>	
Priya Chandran (National Institute of Technology Calicut, India), Shubham Shoundic (National Institute Of Technology Calicut, India), Payas Krishna (National Institute of Technology Calicut, India), Vinod Reddy (National Institute of Technology Calicut, India), Bodasingi Jayachandra (National Institute of Technology, India), Lakshit Pande (National Institute of Technology, Calicut, India).....	1674
<i>A Novel and Highly Secure Encryption Methodology Using a Combination of AES and Visual Cryptography</i>	
Sudhir Rao Rupanagudi (WorldServe Education, India), Varsha Bhat (WorldServe Education, India), Anushree R (KSIT, India), Kavitha YN (KSIT, India), Meghana R (KSIT, India), Arpitha Srinath (KSIT, India), Pooja J (Sapthagiri Institute of Technology, India), Ramya R Pai (Sapthagiri Institute of Technology, India), Roopashree M (Sapthagiri Institute of Technology, India), Sandhya Ramesh (Sapthagiri Institute of Technology, India), Anil C (Jyothy Institute of Technology, India), Anuradha S (Jyothy Institute of Technology, India), Arpita V Murthy (Jyothy Institute of Technology, India), Sridevi S (Jyothy Institute of Technology, India).....	1682

<i>Mathematical Analysis of Novel Compression Algorithm used in OFDM for security</i>	
Alka Sawlikar (Nagpur University & Rajiv Gandhi College of Engineering Research and Technology, India), Zafar Khan (Rajiv Gandhi College of Engineering Research and Technology, India), Sudhir Akojwar (Senior Member IEEE, India)	1689
<i>Multi-Factor Authentication Using Threshold Cryptography</i>	
Vishnu Venukumar (National Institute of Technology Calicut, India), Vinod Pathari (National Institute of Technology Calicut, India)	1694
<i>Multiple Integer Packing for Optimizing Partial Homomorphic Encrypted Databases</i>	
Mythily AS (National Institute of Technology, Calicut, India), Vinod Pathari (National Institute of Technology Calicut, India)	1699
<i>Ecosystem of Spamming on Twitter: Analysis of Spam Reporters and Spam Reportees</i>	
Pooja Sinha (IGDTUW, India), Oshin Maini (Indira Gandhi Delhi Technical University for Women, India), Gunjan Malik (Indira Gandhi Delhi Technical University for Women, India), Rishabh Kaushal (Indira Gandhi Delhi Technical University for Women, India)	1705
<i>Design, Implementation and Security Analysis of Bluetooth Pairing Protocol in NS2</i>	
Samta Gajbhiye (CSVTU Bhilai, India), Sanjeev Karmakar (CSVTU Bhilai, India), Monisha Sharma (CSVTU Bhilai, India), Sanjay Sharma (CSVTU, Bhilai, India)	1711
<i>Experimental Analysis of DDoS Attack and Its Detection in Eucalyptus Private Cloud Platform</i>	
Ashaq Hussain (NIELIT SRINAGAR, India), Beenish Habib (NIT SRINAGAR, India), Farida Khursheed (NIT SRINAGAR, India), M. Tariq Bandy (University of Kashmir, India)	1718
<i>Lightweight Security Algorithm for Low Power IoT Devices</i>	
Tarun Goyal (Malaviya National Institute of Technology, India), Vineet Sahula (MNIT Jaipur, India)	1725
<i>Feature Selection for Novel Fingerprint Dynamics Biometric Technique Based on PCA</i>	
Ishan Bhardwaj (National Institute of Technology Raipur, India), Narendra Londhe (NIT Raipur, India), Sunil Kumar Kopparapu (Tata Consultancy Services, India)	1730
<i>Energy Efficient Multipath Routing for Wireless Sensor Networks: A Genetic Algorithm Approach</i>	
Suneet Gupta (ABESEC, India), Pratyay Kuila (National Institute of Technology Sikkim, India), Prasanta Kumar Jana (Indian School of Mines, India)	1735

ICACCI-20: Embedded Systems/Computer Architecture and VLSI/Adaptive Systems/ICAIS'16 (Short Papers)

<i>A Synthesis Approach for ESOP-based Reversible Circuit</i>	
Chandan Bandyopadhyay (Indian Institute of Engineering Science and Technology (IEST) Shibpur, India), Shalini Parekh (Indian Institute of Engineering Science and Technology (IEST) Shibpur, India), Hafizur Rahman (Bengal Engineering and Science University, Shibpur, India)	1741
<i>Antenna Selection and Transmit Beamforming in MIMO Systems Using Delayed Channel Information At the Transmitter</i>	
Yogesh N Trivedi (Nirma University, India)	1747

<i>Design and Performance Analysis of Quasi-Asynchronous SC-FDMA-CDMA System Using Quasi Complementary Sequence Sets</i> Shikha Singh (Indian Institute of Technology Patna, India), Avik R Adhikary (Indian Institute of Technology Patna, India), Abdus Samad (Indian Institute of Technology Patna, India), Sudhan Majhi (Indian Institute of Technology, India)	1752
<i>Blind Symbol Rate Estimation by Exploiting Cyclostationary Features in Wavelet Domain</i> Sushant Kumar (IIIT Delhi, India), Vivek A Bohara (Indraprastha Institute of Information Technology, Delhi (IIIT-Delhi), India), Sumit Jagdish Darak (IIIT-Delhi, India)	1757
<i>Effortless Exchange of Personal Health Records Using Near Field Communication</i> Sujadevi Vijaya Gangadharan (Amrita University, India), Twintu Kumar (Amrita University, India), Arunjith A S (Amrita University, India), Hrudya P (Research Associate at Amrita Center for Cyber Security, India), Prabakaran Poornachandran (Amrita University, India)	1764
<i>Mitigation of Negative Delay Via Half CP Shift</i> Ajay Sharma (Parallel Wireless, India), Somasekhar Pemmasani (Parallel Wireless, India)	1770
<i>Design of CPW to CPS Printed Balun for Wideband Applications</i> Darshan Shah (Universal, India), Ravish Singh (Thakur Educational Trust, India), Shailendra Shastri (Thakur College of Engineering, India)	1774
<i>Predicting Performance of Applications on Multicore Platforms</i> Priti Ranadive (KPIT Technologies Ltd. India, Principal Scientist, India), Vinay G Vaidya (KPIT Technologies Ltd., India)	1778
<i>Soft Sensor for Inferential Control in Non-Isothermal CSTR</i> Sucheta Singh (NSIT, DELHI, India), Vijander Singh (Netaji subhas institute of Technology, Delhi university, India), Jyoti Yadav (Delhi University & Netaji Subhas Institute of Technology, India), Asha Rani (NSIT University of Delhi NEW Delhi, India)	1785
<i>Lab VIEW Based Four DoF Robotic Arm</i> Sagar Giri (Savitribai Phule Pune University, India), A Ravishankar (Savitribai Phule Pune University, India), Rahul Shivaji Pol (Pune University & VIIT Pune, India), V Ghode (Savitribai Phule Pune University, India)	1791
<i>Performance Evaluation of Fuzzy Logic Controlled Voltage Source Inverter Based Unified Power Quality Conditioner for Mitigation of Voltage and Current Harmonics</i> Anupam Kumar (NIT Srinagar, India), Abdul Bhat (National Institute Of Technology, Srinagar, India), Shubhendra Pratap (NIT Srinagar, India)	1799
<i>Outage Analysis of Two-way Cooperative Spectrum Sharing Protocol under Nakagami-m Fading</i> Saloni Mittal (Indraprastha Institute of Technology, Delhi, India), Vivek A Bohara (Indraprastha Institute of Information Technology, Delhi (IIIT-Delhi), India)	1805
<i>Performance Evaluation of Circuit Level Approaches for Radiation Hardened Primitive Gates</i> Vaibhav Sharma (Maulana Azad National Institute of Technology, India), Arvind Rajawat (Maulana Azad National Institute of Technology, India)	1811
<i>Human Energy Interacting Interface (HEII) (Interface to Transform Environmental Energy Into Human Acquired Energy)</i> Anil Kumar Dubey (Government Engineering College Ajmer, India), Mohan Kolhe (University of Agder, Norway), Vikash Singh (I G National Tribal University Amarkantak, MP, India)	1816

<i>Experimental Study of a Novel Variant of Fiduccia Mattheyses(FM) Partitioning Algorithm</i>	
Mitali Sinha (Veer Surendra Sai University of Technology, Burla, India), Suchismita Pattanaik (Sambalpur University Institute of Information Technology, Burla, Odisha, India), Rakesh Mohanty (Veer Surendra Sai University of Technology Burla, India), Prachi Tripathy (Veer Surendra Sai University of Technology Burla, India)	1820
<i>Removal of Random-Valued Impulse Noise Using Detection Filters and Group Sparse Modeling</i>	
Divya Velayudhan (SCT College of Engineering, India), Salim Paul (SCT College of Engineering, India)	1826

ICACCI-21: Artificial Intelligence and Machine Learning/Data Engineering/Biocomputing (Short Papers)

<i>Multi-Agent Framework for Automatic Deployment and State Restoration in Iterative Software Development Process</i>	
Ramesh Guntha (Amrita Center for Wireless Networks and Applications, Amrita Vishwa Vidyapeetham University, India), Balaji Hariharan (Amrita University, India), Venkat Rangan (Amrita University, India)	1833
<i>Predictive Maintenance for Wind Turbine Diagnostics using Vibration Signal Analysis based on Collaborative Recommendation Approach</i>	
Gopi Krishna Durbhaka (Research Scholar, India), Barani S. (Sathyabama University, Chennai, India)	1839
<i>EDA Wavelet Features as Social Anxiety Disorder (SAD) Estimator in Adolescent Females</i>	
Vivek Sharma (PEC University of Technology, Chandigarh, India), Neelam Prakash (PEC University of Technology, Chandigarh, India), Parveen Kalra (PEC University of Technology, India)	1843
<i>Evaluating Student Performance Using Fuzzy Inference System in Fuzzy ITS</i>	
Pooja Asopa (Banasthali University, India), Sneha Asopa (Banasthali University, India), Nisheet Joshi (Banasthali University, India), Iiti Mathur (Banasthali University, India)	1847
<i>Feasibility Assessment of Neural Network Based Expert System Prototype for Evaluating Motivational Strategies</i>	
Viral Nagori (GLS Institute of Computer Technology (MCA) & GLS University, India), Bhushan H Trivedi (GLS Institute of Computer Technology (MCA), GLS University, India)	1852
<i>Altruistic Decision Making Approach to Resolve the Tragedy of the Commons</i>	
Avadh Kishor (Indian Institute of Technology Roorkee, India), Tarun Garg (Indian Institute of Technology Roorkee, India), Rajdeep Niyogi (Indian Institute of Technology Roorkee, India)	1858
<i>Automatic Expression Recognition and Expertise Prediction in Bharatnatyam</i>	
Pooja Venkatesh (International Institute of Information Technology - Bangalore, India), Dinesh Babu Jayagopi (IIIT Bangalore, India)	1864
<i>A Fast Chromatic Correlation Clustering Algorithm</i>	
Jaishri Gothania (Rajasthan Technical University, India)	1870
<i>A Novel K-Means Based Clustering Algorithm for Big Data</i>	
Ankita Sinha (Indian School of Mines, India), Prasanta Kumar Jana (Indian School of Mines, India)	1875

<i>Cognitive State Classification Using Clustering-Classifer Hybrid Method</i>	
Siva Ramakrishna Jeevakala (M S Ramaiah University of Applied Sciences, India), Hariharan Ramasangu (M. S. Ramaiah University of Applied Sciences, India)	1880
<i>Measuring Stock Price and Trading Volume Causality Among Nifty50 Stocks the Toda Yamamoto Method</i>	
Abinaya P (Amrita School of Business, India), Varsha Suresh Kumar (Amrita University, India), Balasubramanian P (Amrita School of Business, Amrita University, India), Vijay Krishna Menon (Amrita Vishwa Vidyapeetham, India)	1886
<i>Analysis of Fluidized Catalytic Cracking Process Using Fuzzy Logic System</i>	
Aparna Nair (K J Somaiya College of Engineering, India), Rajashree Daryapurkar (KJSCE, Vidyavihar, India)	1891
<i>A Neural Network Based Breast Cancer Prognosis Model with PCA Processed Features</i>	
Smita Jhajharia (Banasthali University, Banasthali & Delhi Technological University, Delhi, India), Harish Varshney (Malaviya National Institute of Technology, India), Seema Verma (University Banasthali Vidyapith, India), Rajesh Kumar (Malaviya National Institute of Technology, India)	1896
<i>Accelerative Gravitational Search Algorithm</i>	
Aditi Gupta (Rajasthan Technical University, India), Nirmala Sharma (Rajasthan Technical University, India), Harish Sharma (Rajasthan Technical University, Kota, India)	1902

ICACCI-23: Signal/Image/video/speech Processing/Computer Vision; and Pattern Recognition & Analysis (Short Papers)

<i>Efficient Signal Processing Algorithms for Radar and Telecommunication Systems</i>	
Rostislav Sokolov (Ural Federal University, Russia), Denis Dolmatov (Ural Federal University, Russia), Renat Abdullin (Ural Federal University, Russia)	1908
<i>A Quantum Parallel Bi-Directional Self-Organizing Neural Network (QPBDSOINN) Architecture for Extraction of Pure Color Objects From Noisy Background</i>	
Debanjan Konar (Sikkim Manipal Institute of Technology & Sikkim Manipal University, India), Udit Chakraborty (Sikkim Manipal Institute of Technology, India), Siddhartha Bhattacharyya (RCC Institute of Information Technology, India), Tapan Gandhi (Indian Institute of Technology Delhi, India), Bijaya Panigrahi (Indian Institute of Technology - Delhi, India)	1912
<i>Detection of Tumor in Brain MRI Using Fuzzy Feature Selection and Support Vector Machine</i>	
Amiya Halder (St. Thomas College of Engineering and Technology, India), Oyendrilla Dobe (St. Thomas College of Engineering and Technology, India)	1919
<i>An Improved Nucleus Segmentation for Cervical Cell Images Using FCM Clustering and BPNN</i>	
Bharti Sharma (Punjabi University Regional Center for IT & Mgmt., India), Kamaljeet Mangat (Punjabi University Patiala, India)	1924
<i>Recognition of Handwritten Devanagiri Numerals by Graph Representation and SVM</i>	
Mohammad Idrees Bhat (University of Mysore & University of Mysore, India), Sharada B. (University of Mysore, India)	1930

<i>Similar Handwritten Devanagari Character Recognition by Critical Region Estimation</i> Mahesh Jangid (Manipal University Jaipur, India), Sumit Srivastava (Manipal University Jaipur, India).....	1936
<i>Soft Proofing of Images Using Bacteria Foraging Optimization of Color Gamuts</i> Nayan Malpani (Rajasthan Technical University, India), Roshan Jain (RCEW Jaipur, India), Saurabh Maheshwari (Govt. Women Engineering College Ajmer & Student Member IEEE, India).....	1940
<i>A Noncontact Vital Sign Monitoring Algorithm Using a Camera</i> Anusree R (Amrita Vishwa Vidyapeetham, India), Ranjith R (Amrita Vishwa Vidyapeetham, India), Ramachandran K I (Amrita Vishwa Vidyapeetham, India).....	1947
<i>Multilevel RDH Scheme Using Image Interpolation</i> Geetha Ramalingam (MIT University & VIT University, India), S Geetha (MIT University Chennai Campus, India).....	1952
<i>Satellite Image Resolution Enhancement Using DTCWT and DTCWT Based Fusion</i> Vineet Naik (V. E. S. Institute of Technology, India), Saylee Gharge (Guide, India).....	1957
<i>Using FPGA-SoC Interface for Low Cost IoT Based Image Processing</i> Shivank Dhote (Vidyalankar Institute Of Technology, India), Pranav Charjan (Vidyalankar Institute of Technology, Mumbai, India), Aditya Phansekar (Vidyalankar Institute of Technology, Mumbai, India), Aniket Hegde (Vidyalankar Institute of Technology, Mumbai, India), Jonathan Joshi (Vanmat Technologies. Pvt. Ltd, India), Sangeeta Joshi (Vidyalankar Institute of Technology, India).....	1963
<i>Image Retrieval Using Extended Bag-of-Visual-Words</i> Nandita Bhattacharya (Indian Institute of Engineering Science and Technology Shibpur, India), Jaya Sil (Indian Institute of Engineering Science and Technology, Shibpur, India).....	1969
<i>An Integrated approach of Radon Transform and Blockwise Binary Pattern for Shape Representation and Classification</i> Bharathi Pilar (Mangalore University & University College Mangalore, India), B H Shekar (Mangalore University, India).....	1976
<i>A Segmented-Mean Feature Extraction Method for Glove-based System to Enhance Physiotherapy for Accurate and Speedy Recuperation of Limbs</i> Andrews Samraj (Mahendra Engineering College, India), Kalvina Rajendran (Enability Foundation for Rehabilitation, India, India), Ramaswamy Palaniappan (University of Kent, United Kingdom).....	1983

ICACCI-29: Sensor Networks, MANETs and VANETs/Distributed Systems (Short Papers)

<i>Web Service Selection with Global Constraints Using Modified Gray Wolf Optimizer</i> Manik Chandra (Indian Institute of Technology Roorkee, India), Ashutosh Agrawal (Indian Institute of Technology Roorkee, India), Avadh Kishor (Indian Institute of Technology Roorkee, India), Rajdeep Niyogi (Indian Institute of Technology Roorkee, India).....	1989
<i>Physical Access Control Based on Biometrics and GSM</i> Diptadeep Addy (St. Thomas' College of Engineering & Technology, Kolkata, India), Poulami Bala (St. Thomas' College of Engineering & Technology, Kolkata, India).....	1995

<i>Network Condition and Application Adaptive Fitness Based Vehicular Intelligent Routing Protocol</i>	
Rajesh Purkait (Indian School Of Mines, India).....	2002
<i>Throughput and Outage of a Wireless Energy Harvesting Based Cognitive Relay Network</i>	
Binod Prasad (NIT DURGAPUR, India), Sankararao Adduru U G (NIT Durgapur, India), Sanjay Dhar Roy (National Institute of Technology Durgapur, India), Sumit Kundu (National Institute of Technology, Durgapur, India).....	2009
<i>Towards Automated Real-Time Detection of Misinformation on Twitter</i>	
Suchita Jain (IGDTUW, India), Vanya Sharma (IGDTUW, India), Rishabh Kaushal (Indira Gandhi Delhi Technical University for Women, India).....	2015
<i>Performance Analysis of Cooperative Communication in Wireless Sensor Network</i>	
Ankit Kumar Jain (National Institute of Technology, Kurukshetra, India), Kaushlendra Pandey (Central Institute of Technology Kokrajhar, India), Soumitra Mehrotra (Jaypee University of Information Technology, India).....	2021
<i>Automated Classification of Security Requirements</i>	
Rajni Jindal (Delhi Technological University, India), Ruchika Malhotra (Delhi Technological University, India), Abha Jain (Delhi Technological University, India).....	2027
<i>Feedback-based Adaptive Speedy Transmission (FAST) Control Protocol to Improve the Performance of TCP Over Ad-Hoc Networks</i>	
Aniket Deshpande (Mewar University, India), Ashok Kaushal (Mewar University, India).....	2034

ICACCI-30: Symposium on Women in Computing and Informatics (WCI-2016) - Short papers

<i>Abnormal Activity Detection for Bank ATM Surveillance</i>	
Rajvi Rajesh Nar (The LNM Institute of Information Technology, India), Alisha Singal (The LNM Institute of Information Technology, India), Praveen Kumar (GRIET, India).....	2042
<i>Energy Efficient Approach to Send Data in Cognitive Radio Wireless Sensor Networks(CRSN)</i>	
Ashish Semwal (GBPEC, PAURI & Uttarakhand, India).....	2047
<i>Robotics and Programming: Attracting Girls to Technology</i>	
Christiane Borges Santos (Instituto Federal de Goiás, Brazil), Deller Ferreira (Federal University of Goiás, Brazil), Maria Carolina Borim do Nascimento R Souza (MNT, Brazil), Andressa Rodrigues Martins (MNT, Brazil).....	2052
<i>Image Hashing by SDQ-CSLBP</i>	
Varsha Patil (University of Mumbai & SIES GST, India), Tanuja K. Sarode (Thadomal Shahani Engineering College, India).....	2057
<i>Statistical Feature Extraction for Small Infrared Target</i>	
Neha Pokhriyal (Aicte, India), Shashikant Verma (Aicte, India).....	2064

ICACCI-31: NLP'16/Natural Language Processing and Machine Translation (Short Papers)

<i>Use of Fuzzy Logic and WordNet for Improving Performance of Extractive Automatic Text Summarization</i> Jyoti Yadav (Malaviya National Institute of Technology, Jaipur, India), Yogesh Kumar Meena (Malaviya National Institute of Technology, India)	2071
<i>Online Recognition of Malayalam Handwritten Scripts - A Comparison Using KNN, MLP and SVM</i> KB Baiju (University of Calicut, India), Sabeerath K (University of Calicut, India)	2078
<i>Ranking Scholarly Work Based on Author Reputation</i> Kajol Kardam (IGDTUW, India), Akshita Kejriwal (IGDTUW, India), Kirti Sharma (IGDTUW, India), Rishabh Kaushal (Indira Gandhi Delhi Technical University for Women, India)	2084
<i>Bayesian Learner Based Language Learnability Analysis of Hindi</i> Sandeep Saini (The LNM Institute of Information Technology, India), Nitin Gupta (The LNM Institute of Information Technology, Jaipur, India), Shivin Bhogal (The LNM Institute of Information Technology, Jaipur, India), Shubham Sharma (The LNM Institute of Information Technology, Jaipur, India), Vineet Sahula (MNIT Jaipur, India)	2089
<i>Extraction of Syllabically Rich and Balanced Sentences for Tigrigna Language</i> Hafta Abera (Ethiopia, Addis Ababa University, Ethiopia), Climent Nadeu (Universitat Politècnica de Catalunya, Barcelona, Spain, Spain), Sebsibe H/Mariam (Addis Ababa University Addis Ababa Ethiopia, Ethiopia)	2094
<i>A Comparative Study of Noise Reduction Techniques for Automatic Speech Recognition Systems</i> Kanika Garg (Jawaharlal Nehru University, India), Goonjan Jain (Jawaharlal Nehru University, India)	2098
<i>Optimizing Feature Extraction Techniques Constituting Phone Based Modelling on Connected Words for Punjabi Automatic Speech Recognition</i> Arshpreet Kaur Chauhan (Chitkara University, Punjab, India)	2104
<i>An Efficient English to Hindi Machine Translation System Using Hybrid Mechanism</i> Jayashree Nair (Amrita School of Engineering, India), Amrutha K (Amrita Vishwa Vidyapeetham Amritapuri, India), Deetha R (Amrita Vishwa Vidyapeetham Amritapuri, India)	2109
<i>Named Entity Recognition in Assamese: A Hybrid Approach</i> Padmaja Sharma (Tezpur University, Tezpur, Assam, India)	2114

ICACCI-32: Embedded Systems/Computer Architecture and VLSI/Adaptive Systems/ICAIS'16 (Short Papers)

<i>Low Power and Temperature Compatible FinFET Based Full Adder Circuit with Optimised Area</i> Jiwanjot Kahlon (Amity University, Uttar Pradesh, India), Pradeep Kumar (Amity University Uttar Pradesh, India), Anubhav Garg (Amity University, India), Ashutosh Gupta (Amity University Uttar Pradesh, India)	2121
<i>Multi-objective Optimization Domino Techniques for VLSI Circuit</i> Jitesh Ramdas Shinde (Priyadarshini J L College of Engineering & TMVLSI, India), Suresh Salankar (G H Raisoni College of	

Engineering Nagpur, India), Shilpa Shinde (Researcher, India).....	2126
<i>Electro-Thermo-Mechanical FE Simulations of OFHC Cu Material for Electric Contact with DC/AC Currents</i>	
Atul S Takalkar (VIT University, India), Lenin babu MC (VIT University, India).....	2131
<i>Characterization of Valveless Micropump for Drug Delivery by Using Piezoelectric Effect</i>	
Atul S Takalkar (VIT University, India), Lenin babu MC (VIT University, India).....	2138
<i>Simulation & Design of Maximum Current Point Tracking Controller for 2 MHz RF H- Source</i>	
Priya Khachane (MPSTME NMIMS & RRCAT, India), Dharmraj Ghodke (Scientific Officer, India), Vinod Senecha (Scientific Officer, India), Vaishali Kulkarni (NMIMS University, India), Satish Joshi (O S, India).....	2145
<i>Multi-Agent Trajectory Control Under Faulty Leader: Energy-Level Based Leader Election Under Constant Velocity</i>	
B. K. Swathi Prasad (M. S. Ramaiah University of Applied Sciences, India), Aditya G Manjunath (M. S. Ramaiah University of Applied Sciences, India), Hariharan Ramasangu (M. S. Ramaiah University of Applied Sciences, India).....	2151
<i>System Analysis for Optical Inter-Satellite Link with Varied Parameter and Pre-Amplification</i>	
Guddan Kumari (Government women engineering college ajmer, India), Chetan Selwal (Government Women Engineering College Ajmer, India).....	2157
<i>Electrocardiogram Waveform Denoising Using a Modified Multi-Resolution Filtered-X LMS Algorithm Based on Discrete Wavelet Transform</i>	
Roop Kanwal (Punjabi University Patiala, India), Sangeet Pal Kaur (Punjabi University Patiala, India).....	2162
<i>Bluetooth RSSI Based Collision Avoidance in Multi-robot Environment</i>	
Lijina P (Amrita Vishwa Vidyapeetham, Amrita School of Engineering, India), Nippun Kumar Aa (Amrita Vishwa Vidyapeetham, Amrita School of Engineering, India).....	2168
<i>A Suboptimal Scheduling Scheme for MIMO Broadcast Channels with Quantized SINR</i>	
Ashok Panda (International Institute of Information Technology, Bhubaneswar, India), Swadhin Mishra (in National Institute of Science and Technology, Berhampore, India), Sasanka Sekhar Dash (Amdocs Development Center, India), Neha Bansal (NIST, Berhampur, India).....	2175
<i>Design and Simulation of Microstage Having PZT MEMS Actuator for 3D Movement</i>	
Kiran Junagal (Rajasthan Technical University Kota Rajasthan India, India), R. s. Meena (UCE, KOTA, India).....	2180
<i>An Analytical Model for a Resource Constrained QoS Guaranteed SINR Based CAC Scheme for LTE BWA Het-Nets</i>	
Arijeet Ghosh (Jadavpur University, India), Iti Misra (Jadavpur University, India).....	2186
<i>Functional Flow Diagram(FFD): Semantics for Evolving Software</i>	
Vaishali Chourey (Medicaps Institute of Technology and Management, India), Meena Sharma (IET - DAVV Institute of Engineering & Technology, DAVV, Indore India, India).....	2193

ICACCI-33: Signal/Image/video/speech Processing/Computer Vision; and Pattern Recognition & Analysis (Short Papers)

Human Face Detection and Recognition in Videos

Swapnil Tathe (Sinhgad College of Engineering, Pune, India), Abhilasha Sandipan Narote (Smt. Kashibai NAvale College Of Engineering, University of Pune, India), Sandipann Pralhad Narote (Government Residence Women Polytechnic, Tasgaon, Sangli, India).....2200

Optimistic Bilateral MAP-MBD Based Color Restoration Using GA

Manavjot Dhaliwal (Guru Nanak Dev University, India).....2206

Optimized Multi-Layered Unequal Error Protection of SPIHT Coded Images Using 64-HQAM

Anam Mobin (Aligarh Muslim University, India), Athar Ali Moinuddin (Aligarh Muslim University, India), Ekram Khan (Aligarh Muslim University, India), Mirza S. Beg (Aligarh Muslim University, India).....2213

Cascaded Speech Enhancement Technique in Highly Nonstationary Noise Environment

Deeleia S (Visvesvaraya Technological University & Bangalore Institute of Technology, India), J C Narayana Swamy (Bangalore Institute of Technology, India), K D N V S Prasad (M-(SRS), CRL, Bharat Electronics Limited, Bangalore, India), D Seshachalam (BMS College of Engineering, India).....2219

Use of OBIA for Extraction of Cadastral Parcels

Ganesh Khadanga (Indian Institute of Technology, Roorkee, India), Kamal Jain (Indian Institute of Technology, Roorkee, India), Suresh Merugu (Indian Institute of Technology, Roorkee & Indian Institute of Technology, Roorkee, India).....2226

Modeling Basal Ganglia Microcircuits Using Spiking Neurons

Chaitanya Medini (Amrita Vishwa Vidyapeetham (Amrita University), India), Anjitha Thekkekuriyadi (Amrita Vishwa Vidyapeetham, Amrita University, India), Surya Thayyilekandi (Amrita Vishwa Vidyapeetham, Amrita University, India), Manjusha Nair (Amrita School of Biotechnology, Amrita Vishwa Vidyapeetham, India), Bipin Nair (Amrita Vishwa Vidyapeetham (Amrita University), India), Shyam Diwakar (Amrita Vishwa Vidyapeetham (Amrita University), India).....2231

Performance Improvement in HEVC Using Contrast Sensitivity Function

Sini Simon M (NIT Calicut, India), Abhilash Antony (National Institute of Technology Calicut, India), Sreelekha G (National Institute Of Technology, India).....2237

Shot Boundary Detection Using Correlation Based Spectral Residual Saliency Map

B H Shekar (Mangalore University, India), K P Uma (Mangalore University, India), Raghurama Holla, K (Mangalore University, India).....2242

ICACCI-08: Poster Session I

<i>Analysis of Nutritional Deficiency in Citrus Species Tree Leaf Using Image Processing</i> Chitra Anil Dhawale (Amravati University, India), Sanjay Misra (Suite 11, Covenant University & Covenant University, Nigeria), Sonika Thakur (S. G. B. Amravati University, India), Navin Dattatraya Jambhekar (SGB Amravati University Amravati & S. S. S. K. R. Innani Mahavidyalaya Karanja Lad, India).....	2248
<i>Factors Affecting the Consumer Preference of Non-Packaged Non-Branded Rice in South India</i> Rajiv Prasad (Amrita Vishwa Vidyapeetham University & Amrita School of Business, India), Umesh Sivasubramanian (Amrita Vishwa Vidyapeetham University, India).....	2253
<i>Internal crack detection in kidney bean seeds using X-ray imaging technique</i> Surbhi Sood (National Institute of Technical Teachers Training and Research (NITTTR), Chandigarh & Panjab University, Chandigarh, India), Shveta Mahajan (AcSIR, CSIR-CSIO, India), Amit Doegar (National Institute of Teachers Training and Research, India), Amitava Das (CSIO, India).....	2258
<i>A Planning Based Approach For Satisfying User Request in Context Aware Settings</i> Sujata Swain (Indian Institute of Technology Roorkee, India), Rajdeep Niyogi (Indian Institute of Technology Roorkee, India).....	2262
<i>Named Entity Recognition and Classification for Gujarati Language</i> Komil Vora (V. V. P Engineering College, India), Avani Vasant (Babaria Institute of Technology & Science, India), Rachit Adhvaryu (Gujarat Technological University, India).....	2269
<i>An automated system for measuring hematocrit level of human blood from total RBC count</i> Ratnadeep Dey (Jadavpur University, India), Kaushiki Roy (Jadavpur University, India), Debotosh Bhattacharjee (Jadavpur University, India), Mita Nasipuri (Jadavpur University, India), Pramit Ghosh (RCC Institute of Information Technology, India).....	2273
<i>Summarization of Customer Reviews for a Product on a website using Natural Language Processing</i> Akkamahadevi Hanni (B V Bhoomaraddi College of Engineering and Technology, India), Mayur Patil (Tesco Bengaluru, India), Priyadarshini M Patil (BVB College of Engineering & Technology, India).....	2280
<i>Distributed threshold k-means clustering for privacy preserving data mining</i> Vadlana Baby (VNR VIGNANA JYOTHI INSTITUTE OF ENGG & TECH, India).....	2286
<i>A Survey on Extracting Frequent Subgraphs</i> Susanna Thomas (Amrita School of Engineering, Amritapuri, Amrita Vishwa Vidyapeetham, Amrita University, India), Jyothisha J Nair (Amrita University, India).....	2290
<i>Internet of Things: A Survey Related to Various Recent Architectures and Platforms Available</i> Sharwari Solapure (Walchand College of Engineering, India), Harish Kenchannavar (Gogte Institute of Technology & Visveswaraya Technological University, India).....	2296
<i>Customizable Holter Monitor Using Off-The-Shelf Components</i> Neena Goveas (BITS Pilani K K Birla Goa Campus, India), Sreekish S (BITS Pilani K K Birla Goa Campus, India), Abhimanyu Zala (BITS Pilani K K Birla Goa Campus, India), Keerthi Chavan G (BITS PILANI & Goa Campus, India).....	2302

<i>DEPTA: An Efficient Technique for Web Data Extraction and Alignment</i>	
Rahull Lokhande (SRTMU Nanded & SGGSI&T NANDED, India)	2307
<i>Usage of Lowpass Filters for Miniaturization of Microstrip Branch-Line Hybrid Couplers</i>	
Denis Letavin (Ural Federal University, Russia), Yury E Mitelman (Ural Federal University, Russia), Victor Chechetkin (Ural Federal University, Russia)	2311
<i>Miniature Microwave Bandpass Filter with Two Circular Spiral Resonators</i>	
Denis Letavin (Ural Federal University, Russia), Victor Chechetkin (Ural Federal University, Russia)	2315
<i>Statistical Analysis of Load Demand Distribution At Banaras Hindu University, India</i>	
Manish Kumar (Indian Institute of Technology (BHU), Varanasi, India), Cherian Samuel (Indian Institute of Technology (BHU), Varanasi, India)	2318
<i>Allocating Resources in Cloud Computing When Users Have Strict Preferences</i>	
Anjan Bandyopadhyay (NIT DURGAPUR, India), Sajal Mukhopadhyay (NIT DURGAPUR, India), Uttam Ganguly (Mallabhum Institute of Technology, India)	2324
<i>Identification of Escalations During Product Maintenance</i>	
Shivam Dhar (PES Institute of Technology, India), Pooja Tata (PES Institute Of Technology, India), Sachit Nayak (PES Institute of Technology, India), Subramaniam Kalambur (PES University, India), Dinkar Sitaram (Pesit, India), Atanu Dasgupta (Hewlett Packard Enterprise, India)	2329
<i>A Framework to Identify Influencers in Signed Social Networks</i>	
Vanita Jaitly (Chitkara University, India), Pradeep Chowriappa (Louisiana Tech University, USA), Sumeet Dua (Louisiana Tech University, USA)	2335
<i>Blind and Adaptive Reconstruction Approach for Non-Uniformly Sampled Wideband Signal</i>	
Himani Joshi (IIIT-Delhi, India), Sumit Jagdish Darak (IIIT-Delhi, India), Yves Louet (CentraleSupélec, France)	2341
<i>RFID-Cloud Smart Cart System</i>	
Alex Pappachen James (Nazarbayev University & Enview R&D Labs, Kazakhstan), Yerlan Berdaliyev (Nazarbayev University, Kazakhstan)	2346
<i>A Real Time Speech to Text Conversion System Using Bidirectional Kalman Filter in Matlab</i>	
Neha Sharma (Chandigarh University Gharuan, Mohali, India), Shipra Sardana (Chandigarh University Gharuan, Mohali, India)	2353
<i>Electrooculogram-based Virtual Reality Game Control Using Blink Detection and Gaze Calibration</i>	
Devender Kumar (IIT Kanpur & IIT Kanpur, India), Amit Sharma (IIT Kanpur, India)	2358
<i>Emotion Recognition on the Basis of Audio Signal Using Naive Bayes Classifier</i>	
Sagar Bhakre (Vishvakarma Institute of Information Technology pune, India), Arti Bang (University of Pune, India)	2363
<i>Gesture recognition based relative intensity profiler for different light sources</i>	
Sabarna Choudhury (St. Thomas' College of Engineering and Technology, Kolkata, India), Shreyasi Bandyopadhyay (St. Thomas' College of Engineering and Technology, Kolkata, India), Kanik Palodhi (University of Calcutta, India)	2368
<i>Improved GA using population Reduction for Load Balancing in Cloud computing</i>	

Ronakkumar R Patel (Sardar Pate College of Engineering & Gujarat Technological University, India), Swachilkumar Patel (Sardar Patel College of Engineering, India, India), Dhaval Patel (Sardar Patel College of Engineering, India), Tushar T Desai (Parul Polytechnic Institute, India)	2372
<i>Image Enhancement of Ultrasound Images using Multifarious Denoising Filters and GA</i>	
Prabhpreet Kaur (Gndu, India), Gurvinder Singh (G N D U, India), Parminder Kaur (Guru Nanak Dev University, Amritsar, India)	2375
<i>Unmanned Aerial Vehicle based Bomb Detection</i>	
Jasmine Priyadarsini (VIT University, Vellore, INDIA, India)	2385

Poster Session II

<i>A study of peak to average power ratio for different companding techniques in VLC-OFDM system</i>	
Arushi Singh (Rajiv Gandhi Prodyogiki Vishwavidyalaya, Bhopal, India), Anjana Jain (Shri. G. S. Institute of Technology & Science, India), Prakash Vyavahare (S G S Institute of Technology and Science, India)	2390
<i>Need of Integration of Second Generation Wavelets in Medical Image Compression</i>	
Harshal Gosavi (Vishwakarma Institute of Information Technology, Pune, India), Rajendra Talware (Vishwakarma Institute of Information Technology, Pune, India)	2394
<i>Low Power Circuit Techniques for Optimizing Power in High Speed SRAM</i>	
Navneet Kaur Saini (IIT DELHI & Solid State Physics Laboratory under DRDO, India), Aniruddha Gupta (IIT DELHI & NXP Semiconductors, India), Ravija Prashar (IIT DELHI, India), Parul Gupta (IIT DELHI, India)	2399
<i>Alarm Notification to Tower Monitoring System in oneM2M Based IOT Networks</i>	
Pankaj Kumar Dalela (C-DOT, India), Arun Yadav (C-DOT, India), Smriti Sachdev (C-DOT, India), Saurabh Basu (Research Engineer, India), Anurag Yadav (C-DOT, India), Vipin Tyagi (C-DOT, India)	2405
<i>Robust Features for Spoofing Detection</i>	
Sathya Ashok (Amrita Vishwa Vidyapeetham, India), Swetha Jayaprakash (Amrita Vishwa Vidyapeetham, India), Arun Das K (Amrita Vishwa Vidyapeetham, India), Kuruvachan K George (Amrita Vishwa Vidyapeetham, India), Santhosh C Kumar (Amrita Vishwa Vidyapeetham, India), Aravinth J (Amrita Vishwa Vidyapeetham, India)	2410
<i>Improving K-Means Through Better Initialization and Normalization</i>	
Akanksha Choudhary (Gurukul Institute of Engineering and Technology, Kota, India), Prashant Sharma (Gurukul Institute of Engineering and Technology, Kota, India), Manoj Singh (Gurukul Institute of Engineering and Technology, India)	2415
<i>Discrete Event System Framework for Analysis and Modeling of Job Shop Scheduling System</i>	
Om Shukla (Malaviya National Institute of Technology Jaipur, Rajasthan, India), Sujil A (MNIT JAIPUR, India), Gunjan Soni (Malaviya National Institute of Technology Jaipur, Rajasthan, India), Rajesh Kumar (Malaviya National Institute of Technology, India)	2420
<i>Facial Recognition Using Discrete ABC</i>	
Akshay Kallianpur (MSRIT, India), Aditya Kalyani (MSRIT, India), Subramanya Naligay (MSRIT, India), Jagadish S Kallimani	

(Associate Professor, Department of Computer Science and Engineering, MS Ramaiah Institute of Technology, Bangalore, India).....	2425
<i>Best Offer Recommendation Service</i>	
Kiran Javkar (Samsung R&D Institute India - Bangalore, India), Siddharth Vora (Samsung R&D Institute India - Bangalore, India), Joy Bose (Samsung R&D Institute India, Bangalore, India), Amit Rodge (Samsung R&D Institute India - Bangalore, India), Hitesh Sharma (Samsung R&D Institute India - Bangalore, India).....	2430
<i>Classification of Pulmonary Crackles and Pleural Friction Rubs Using MFCC Statistical Parameters</i>	
Sibghatullah Khan (Babasaheb Naik College of Engineering PUSAD & Sant Gadge Baba Amravati University Amravati, India), Vasif Ahmed (Babasaheb Naik College of Engg., Pusad, India).....	2437
<i>Intelligent Imputation Technique for Missing Values</i>	
Tahani Aljuaid (Gannon University, USA), Sreela Sasi (Gannon University, USA).....	2441
<i>DTMOS based low voltage high performance FVF-OTA and Its application in MISO Filter</i>	
Niharika Narang (NSIT, India), Bhawna Aggarwal (Netaji Subhas Institute of Technology, India), Maneesha Gupta (Netaji Subhas Institute of Technology & University of Delhi, India).....	2446
<i>Cloud Service Orchestration Based Architecture of OpenStack Nova and Swift</i>	
Pragya Jain (University of delhi, India), Aparna Datt (University of Delhi & PGDAV College, India), Anita Goel (Dyal Singh College, University of Delhi, India), Sc Gupta (Institute of Information Technology (IIT), Delhi, India, India).....	2453
<i>Design and Characterization of Analog Multiplexer for Data Acquisition System in Satellites</i>	
Venkata Sai krishna Vallury (Amrita School of Engineering, Bangalore, India), K S Saikiran (Amrita School of Engineering, Bangalore, India), Guditi Nagaraja (Amrita School of Engineering, Bangalore, India), Padmapriya K (ISRO Satellite Centre, Bangalore, India), Kavitha N Pillai (Amrita School of Engineering, Bangalore, India).....	2460
<i>Development of Low Cost EMG Data Acquisition System for Arm Activities Recognition</i>	
Sidharth Pancholi (Thapar University, India), Ravinder Agarwal (Thapar University, India).....	2465
<i>Multi-objective Moth Flame Optimization</i>	
Vikas Choudhary (Malaviya National Institute of Technology Jaipur, India), Satyasai Jagannath Nanda (Malaviya National Institute of Technology Jaipur, India).....	2470
<i>A Comparative Study of QoS Ranking Prediction Techniques in Cloud Services</i>	
Shirish Nagar (Manipal University, Jaipur & Poornima College of Engineering, India), Jyotirmoy Karjee (Indian Institute of Science, India).....	2477
<i>A Secure Software Design Methodology</i>	
Rajat Goel (Malaviya National Institute of Technology Jaipur, India), Mahesh Chandra Govil (Malaviya National Institute of Technology Jaipur, India), Girdhari Singh (Malaviya National Institute of Technology Jaipur, India).....	2484
<i>Driver's Distraction Detection Based on Gaze Estimation</i>	
Shweta Maralappanavar (B. V. Bhoomraddi College Of Engineering and Technology, India), ReenaKumari Behera (KPIT Technologies Ltd., India), Uma Mudenagudi (B. V Bhoomaraddi College of Engineering and Technology, Hubli, India).....	2489
<i>Minimally Supervised Sound Event Detection Using a Neural Network</i>	

Aditya Agarwal (P. E. S. University, India), Syed Munawwar Quadri (P. E. S. University, India), Savitha Murthy (P. E. S. University, India), Dinkar Sitaram (Pesit, India).....	2495
<i>An Advanced Authentication System for Multi Server Environment with Snort</i>	
Matta Divya Sai (St Martins Engineering College, India), R. Ch A Naidu (JNTU Hyderabad, India), Voni Sudharani V (ST MARTIN'S COLLEGE OF ENGG, India), M Sai Krishna Murthy (JNTUH, India), Meghana K (JNTUK, India).....	2501
<i>Role of Codec Selection on the Performance of IPsec Secured VoIP</i>	
Emmanuel Antwi-Boasiako (Ghana Institute of Management and Public Administration, Ghana), Eric Kuada (Ghana Institute of Management and Public Administration, Ghana), Kwasi Boakye-Boateng (Ghana Institute of Management and Public Administration, Ghana).....	2508
<i>Measurement Results for Direct and Single Hop Device-to-Device Communication Protocol</i>	
Vibhutesh Kumar Singh (Indraprastha Institute of Information Technology Delhi, India), Hardik Chawla (BITS Goa, India), Vivek A Bohara (Indraprastha Institute of Information Technology, Delhi (IIIT-Delhi), India).....	2515
<i>Mid-infrared Supercontinuum Generation in Ge11.5As24Se64.5 Based Chalcogenide Photonic Crystal Fiber</i>	
Sandeep Vyas (Malaviya National Institute of Technology, Jaipur & Vivekanand Institute of Technology (East), India).....	2521
<i>Analysis of Outage Performance of Opportunistic AF OFDM Relaying in Nakagami-m Channels</i>	
Piyush Kumar (Indian Institute of Technology Patna, India), Sudhan Majhi (Indian Institute of Technology, India), Youssef Nasser (American University of Beirut, Lebanon).....	2527
<i>Performance Evaluation of LTE Network: An Energy Saving and Capacity Gain Perspective</i>	
Sapna Thapar (The LNMIIT, JAIPUR, India), Purnendu Karmakar (The LNM Institute of Information Technology, India).....	2532
<i>Design And Gain Enhancement Of A CPW-Fed Dual Band Slot Antenna Using A Metamaterial Inspired Superstrate</i>	
Sk Islam (Indian Institute of Engineering Science and Technology, Shibpur, India).....	2539
<i>Network Processor - A simplified approach for transport layer offloading on NIC</i>	
Geetanjali Gadre (C-DAC, India), Shreeya Badhe (C-DAC, India), Kedar Kulkarni (C-DAC, India).....	2542
<i>DESH: Database Evaluation System With Hibernate ORM Framework</i>	
Gunasingh Gabriel (SSN College of Engineering, India), Chitra Babu (SSN Engineering College, India).....	2549
<i>An Effective Emitter-Source Localisation-based PUEA Detection Mechanism in Cognitive Radio Networks</i>	
Dikita Salam (North Eastern Regional Institute of Science and Technology, India), Amar Taggu (North Eastern Regional Institute of Science and Technology, India), Ningrinla Marchang (North Eastern Regional Institute of Science and Technology, Arunachal Pradesh, India).....	2557
<i>Adopting Ant Colony Optimization for Supervised Text Classification</i>	
Mohammed Wajeed (Jyothi Engineering College & Kerala, India), T Adilakshmi (Vasavi College of Engineering, India).....	2562
<i>The Current State of Voice Over Internet Protocol in Wireless Mesh Networks</i>	
Mohammad Tariq Meeran (Tallinn University & Kabul University, Estonia), Yannick Le Moullec (Tallinn University of Technology, Estonia), Paul Annus (Tallinn University of Technology, Estonia).....	2567
<i>Detection of Distributed Denial of Service Attacks in Software Defined Networks</i>	

Lohit Barki (B V Bhoomaraddi College of Engineering and Technology, India), Amrit Shidling (B V Bhoomaraddi College of Engineering and Technology, India), Nisharani Meti (B V Bhoomaraddi College of Engineering and Technology, India), Narayan D. G. (BVB College of Engineering and Technology, Hubli. Karnataka, India), Mohammed Moin Mulla (KLE Technological University, Hubli, Karnataka, India).....	2576
<i>Beacon Controlled Campus Surveillance</i>	
Gaurav Saraswat (Guru Gobing singh Indraprasth Universitg & Maharaja Agrasen Institute of Technology, India), Varun Garg (Guru Gobind Singh Indraprasth University, India).....	2582

ICACCI-26: Poster Session III

<i>RFID and Android Based Smart Ticketing and Destination Announcement System</i>	
Prasun Chowdhury (St. Thomas' College of Engineering & Technology, Kolkata, India), Poulami Bala (St. Thomas' College of Engineering & Technology, Kolkata, India), Diptadeep Addy (St. Thomas' College of Engineering & Technology, Kolkata, India), Sumit Giri (St. Thomas' College of Engineering & Technology, Kolkata, India), Aritra Ray Chaudhuri (St. Thomas' College of Engineering & Technology, Kolkata, India).....	2587
<i>Impact of Algorithm Complexity on Energy Utilization of Wireless Sensor Nodes</i>	
VMLekshmy (Amrita Center for Wireless Networks and Applications, India).....	2592
<i>Feasibility and Performance Evaluation of VANET Techniques to Enhance Real-time Emergency Healthcare Services</i>	
Adwitiya Mukhopadhyay (Amrita Vishwa Vidyapeetham, Amrita University, India), Raghunath S (Amrita Vishwa Vidyapeetham, Amrita University, India), Kruti M (Amrita Vishwa Vidyapeetham, Amrita University, India).....	2597
<i>Implementation of Ignition Control with on Board Diagnosis</i>	
Rishi Dev (Amrita University, India), Shanmughasundaram R (Amrita University, India).....	2604
<i>Localization of sensor nodes using Modified Particle Swarm Optimization in Wireless Sensor Networks</i>	
Neelam Barak (IGDTUW, India), Neha Gaba (IGDTUW, India), Shipra Aggarwal (IGDTUW, India).....	2608
<i>A Study on the Impact of Macroeconomic Factors on s&p BSE Bankex Returns</i>	
Shilpa Sudhakaran (Amrita Vishwa Vidyapeetham University, India), Balasubramanian P (Amrita School of Business, Amrita University, India).....	2614
<i>The Terrain Identification by the Pulse Radar Altimeter</i>	
Artem Sorokin (Ural Federal University, Russia), Vladimir Vazhenin (Ural Federal University, Russia), Lubov Lesnaya (Ural Federal University, Russia).....	2619
<i>Power Aware Scheduling on Real-time Multi-core Systems</i>	
Amit Hanamakannavar (BVB College of Engineering and Technology, PG Student, India), Vidya Handur (BVB Colloge of Engineering and Technology, Associate Professor, India), Priti Ranadive (KPIT Technologies Ltd. India, Principal Scientist, India), Venkatesh Kareti (KPIT Technologies Ltd. India, Sr Research Associate, India).....	2624
<i>Multi-Functional Secured Smart Home</i>	

Vinay Kumar Mittal (Indian Institute of Technology Chittoor, Sri City, India), C. V. Raghavendra Dharma Savarni (Indian Institute of Information Technology, Sricity, Chittoor, India), Gajjala Viswanatha Reddy (Indian Institute of Information Technology, Sricity, Chittoor, India), G. Rambabu Yadav (Indian Institute of Information Technology, Sricity, Chittoor, India), Md Shariq Suhail (Indian Institute of Information Technology, Sricity, India)	2629
<i>Information Retrieval in Web Crawling A Survey</i>	
Chandni Saini (Thapar University, India), Vinay Arora (Patiala, Punjab & Thapar University, India)	2635
<i>Design of a Wide Output Range and Reduced Current Mismatch Charge Pump PLL with Improved Performance</i>	
Sujata Pandey (AMITY University, Noida, India), Monika Bhardwaj (Amity University, India)	2644
<i>Net Energy Meter with Appliance Control and Bi-directional Communication Capability</i>	
Tania Tony (Amrita Vishwa Vidyapeetham, Amrita University, India), Sivraj P (Amrita Vishwa Vidyapeetham, Amrita University & Amrita School of Engineering, India), Sasi K Kottayil (Amrita Vishwa Vidyapeetham, Amrita University, India)	2650
<i>An Intelligent Controller for Smart Home</i>	
Vishnu Babu (Amrita Vishwa Vidyapeetham, Amrita University, India), Ashwin Kumar U (Amrita Vishwa Vidyapeetham, India), Priyadarshini Ramasamy (Amrita School Of Engineering, India), Krithika Premkumar (Amrita Vishwa Vidyapeetham, India), Nithin S (Amrita Vishwa Vidyapeetham, India)	2654
<i>Design of Linear Phase Low Pass FIR Filter Using Restart Particle Swarm Optimization</i>	
Himanshu Gupta (SGSITS, Indore, India), Deepak Mandloi (SGSITS, India), Anand Jat (SGSITS, India), Arpit Gupta (SGSITS, India), Prabhakar Ojha (CDGI, India)	2658
<i>Demographic Analysis of Twitter Users</i>	
Geeta Singh (Indian Institute of Technology Roorkee, India), Rajdeep Niyogi (Indian Institute of Technology Roorkee, India)	2662
<i>Textual Content Based Information Retrieval From Twitter</i>	
Waseem Ahmad (Aligarh Muslim University, Aligarh, India), Rashid Ali (AMU Aligarh, India)	2668
<i>Distributed Image Processing Using Hadoop and HPI</i>	
Swapnil Arsh (The LNM Institute of Information Technology, India), Abhishek Bhatt (The LNM Institute of Information Technology, India), Praveen Kumar (VNIT, Nagpur, India, India)	2673
<i>A Correlation Based SVM-Recursive Multiple Feature Elimination Classifier for Breast Cancer Disease Using Microarray</i>	
Kavitha KR (Amrita School of Engineering Amritapuri, India), Syamili RajendranG (Amrita School of Engineering Amritapuri, India), Varsha J (Amrita School of Engineering Amritapuri Kerala, India)	2677
<i>T-Slotted Microstrip Patch Antenna for 5G WI-FI Network</i>	
Ravi Kumar Goyal (RTU & GOVT. ENGG. COLLEGE AJMER, India), Kamlesh Kumar Sharma (MNIT, India)	2684
<i>Backpropagation Artificial Neural Network for Determination of Glucose Concentration From NearInfra Red Spectra</i>	
Bilal Malik (University of Kashmir, India)	2688
<i>Pattern Generation and Symmetric Key Block Ciphering Using Cellular Automata</i>	
Rajat Mehta (Dr B R Ambedkar NIT Jalandhar, India), Rajneesh Rani (Dr B R Ambedkar NIT Jalandhar, India)	2692
<i>An Efficient Spatial Domain based Image Watermarking using Shell Based Pixel Selection</i>	

Shubham Mathur (VIT University, India), Akshay Dhingra (VIT University, India), Manoharan Prabukumar (VIT University, India), Agilandeewari Loganathan (VIT University, India), Muralibabu K (Lord Ayyapa Institute of Engineering and Technology, India)	2696
<i>Anomaly Detection Based Multi Label Classification Using Association Rule Mining (ADMLCAR)</i>	
Prathibhamol Cp (Amrita University, India), Amala G s (Amrita School of Engineering, India), Malavika Kapadia (Amrita School of Engineering, India)	2703
<i>Multi Label Classification Based on Logistic Regression (MLC-LR)</i>	
Prathibhamol Cp (Amrita University, India), Jyothy K v (Amrita School of Engineering, India), Noora B (Amrita School of Engineering, India)	2708
<i>ECSim: A Simulation Tool for Performance Evaluation of Erasare Coded Storage Systems</i>	
Ojus Thomas Lee (NIT Calicut & NIT Calicut, India), S D Madhu Kumar (National Institute of Technology Calicut, India), Priya Chandran (National Institute of Technology Calicut, India)	2713
<i>Real Time Performance Evaluation of Energy Detection Based Spectrum Sensing Algorithm Using WARP Board</i>	
H Yerranna (University of Hyderabad, India), Samrat Sabat (University of Hyderabad, India), Sunil Devanahalli Krishnamurthy (University of Hyderabad, India), Siba Kumar Udgata (University of Hyderabad, India)	2719
<i>Design of Bioimpedance Spectrometer</i>	
Abhijit S. Patil (Vishwakarma Institute Of Information Technology (Affiliated To Savitribai Phule Pune University), India), Rajesh Bhaskar Ghongade (Vishwakarma Institute of Information Technology, India)	2724
<i>Is Sentiment Analysis an Art or a Science? Impact of lexical richness in training corpus on machine learning</i>	
Sanchit Garg (HMR Institute of Technology & Management, India), Aashish Saini (HMR Institute of Technology & Management, India), Nitika Khanna (HMR Institute of Technology & Management, India)	2729
<i>Performance Evaluation of Different Color Models Used in Color Iris Authentication</i>	
Abhilasha Sandipan Narote (Smt. Kashibai NAVale College Of Engineering, University of Pune, India), Laxman Madhavrao Waghmare (SGGS College of Engineering and Technology, SRMTU Nanded, India)	2736
<i>An E-business Chatbot using AIML and LSA</i>	
Thomas N T (Amrita University & Amrita Vishwa Vidyapeetham, India)	2740
<i>Classification of Mammogram Images by using CNN Classifier</i>	
Ketan Sharma (Chandigarh University, Mohali, India)	2743
<i>A novel technique for LED dot-matrix text detection and recognition for non-uniform color system</i>	
Vandana Jhatwal (Chandigarh University, India)	2750
<i>An Integrated Speech Processing Method Utilizing General Kalman Filter</i>	
Vijay Kiran Battula (University College of Engineering Vizianagaram, JNTU KAKINADA, India), Appala naidu Gottapu (University College of Engineering Vizianagaram, JNTU KAKINADA, India)	2755
<i>Vehicle Trajectory Prediction using a Catadioptric Omnidirectional Camera</i>	
Vigneshram Krishnamoorthy (National Institute of Technology Tiruchirappalli, India), Saksham Agarwal (Indian Institute of Technology Kanpur, India), K. s. Venkatesh (Indian Institute of Technology, Kanpur, India)	2761

<i>ECG Signal Analysis using Wavelet Coherence and S-Transform for Classification of Cardiovascular Diseases</i>	
Saksham Agarwal (Indian Institute of Technology Kanpur, India), Vigneshram Krishnamoorthy (National Institute of Technology Tiruchirappalli, India), Sawon Pratihier (Indian Institute Of Technology Kanpur, India).....	2765
<i>Investigation of CO-OFDM system using VCSEL for long reach systems employing symmetrical dispersion compensation modules</i>	
Garima Chouhan (Chandigarh University, India).....	2771
<i>Sensible Approach for Soil Fertility Management Using GIS Cloud</i>	
Leena H u (Siddaganga Institute of Technology, India), Premasudha BG (Siddaganga Institute of Technology, Tumkur, Karnataka, India).....	2776

proceedings.com

SEARCH | ORDERS | NEWS | CONTACT US

866-864-0401

Research in Computational Intelligence and Communication Networks, International Conference, 2nd 2013, (KORCIN 2013) (CII-ICCN)

Our Price: **\$232.00**
Heavy (Not Mailing) \$232.00

ADD TO CART

Product Description

Title	2013 Second International Conference on Research in Computational Intelligence and Communication Networks, International Conference, 2nd 2013, (KORCIN 2013) (CII-ICCN)
Date	Proceedings of a meeting held 22-26 September 2013, Kolkata, India
ISBN	9781450313448
Pages	0
Format	CD-ROM
ISBN	9781450313448
Price	US\$232.00 (incl. GST)
CCC Part	Current Association, Inc. (Part 2017)

Related Products

- COMPUTATIONAL INTELLIGENCE INTERNATIONAL CONFERENCE 2013 (CII-ICCN)
- DESIGN & AUTOMATIC AND CONTROL SYSTEMS CONFERENCE 2013 (DACON)
- IEEE INTERNATIONAL CONFERENCE ON SYSTEMS, MAN & CYBERNETICS (SMC)

Advances in Intelligent Systems and Computing

Volume 562

Series editor

Janusz Kacprzyk, Polish Academy of Sciences, Warsaw, Poland
e-mail: kacprzyk@ibspan.waw.pl

About this Series

The series “Advances in Intelligent Systems and Computing” contains publications on theory, applications, and design methods of Intelligent Systems and Intelligent Computing. Virtually all disciplines such as engineering, natural sciences, computer and information science, ICT, economics, business, e-commerce, environment, healthcare, life science are covered. The list of topics spans all the areas of modern intelligent systems and computing.

The publications within “Advances in Intelligent Systems and Computing” are primarily textbooks and proceedings of important conferences, symposia and congresses. They cover significant recent developments in the field, both of a foundational and applicable character. An important characteristic feature of the series is the short publication time and world-wide distribution. This permits a rapid and broad dissemination of research results.

Advisory Board

Chairman

Nikhil R. Pal, Indian Statistical Institute, Kolkata, India

e-mail: nikhil@isical.ac.in

Members

Rafael Bello Perez, Universidad Central “Marta Abreu” de Las Villas, Santa Clara, Cuba

e-mail: rbellop@uclv.edu.cu

Emilio S. Corchado, University of Salamanca, Salamanca, Spain

e-mail: escorchado@usal.es

Hani Hagrass, University of Essex, Colchester, UK

e-mail: hani@essex.ac.uk

László T. Kóczy, Széchenyi István University, Győr, Hungary

e-mail: koczy@sze.hu

Vladik Kreinovich, University of Texas at El Paso, El Paso, USA

e-mail: vladik@utep.edu

Chin-Teng Lin, National Chiao Tung University, Hsinchu, Taiwan

e-mail: ctlin@mail.nctu.edu.tw

Jie Lu, University of Technology, Sydney, Australia

e-mail: Jie.Lu@uts.edu.au

Patricia Melin, Tijuana Institute of Technology, Tijuana, Mexico

e-mail: epmelin@hafsamx.org

Nadia Nedjah, State University of Rio de Janeiro, Rio de Janeiro, Brazil

e-mail: nadia@eng.uerj.br

Ngoc Thanh Nguyen, Wroclaw University of Technology, Wroclaw, Poland

e-mail: Ngoc-Thanh.Nguyen@pwr.edu.pl

Jun Wang, The Chinese University of Hong Kong, Shatin, Hong Kong

e-mail: jwang@mae.cuhk.edu.hk

More information about this series at <http://www.springer.com/series/11156>

Ramesh K. Choudhary · Jyotsna Kumar Mandal
Dhananjay Bhattacharyya
Editors

Advanced Computing and Communication Technologies

Proceedings of the 10th ICACCT, 2016

 Springer

Editors

Ramesh K. Choudhary
Asia Pacific Institute of Information
Technology
Panipat, Haryana
India

Dhananjay Bhattacharyya
Computational Science Division
Saha Institute of Nuclear Physics
Kolkata, West Bengal
India

Jyotsna Kumar Mandal
Department of Computer Science
and Engineering
Faculty of Engineering, Technology
and Management
Kalyani University
Kalyani, West Bengal
India

ISSN 2194-5357

ISSN 2194-5365 (electronic)

Advances in Intelligent Systems and Computing

ISBN 978-981-10-4602-5

ISBN 978-981-10-4603-2 (eBook)

<https://doi.org/10.1007/978-981-10-4603-2>

Library of Congress Control Number: 2017940607

© Springer Nature Singapore Pte Ltd. 2018

This work is subject to copyright. All rights are reserved by the Publisher, whether the whole or part of the material is concerned, specifically the rights of translation, reprinting, reuse of illustrations, recitation, broadcasting, reproduction on microfilms or in any other physical way, and transmission or information storage and retrieval, electronic adaptation, computer software, or by similar or dissimilar methodology now known or hereafter developed.

The use of general descriptive names, registered names, trademarks, service marks, etc. in this publication does not imply, even in the absence of a specific statement, that such names are exempt from the relevant protective laws and regulations and therefore free for general use.

The publisher, the authors and the editors are safe to assume that the advice and information in this book are believed to be true and accurate at the date of publication. Neither the publisher nor the authors or the editors give a warranty, express or implied, with respect to the material contained herein or for any errors or omissions that may have been made. The publisher remains neutral with regard to jurisdictional claims in published maps and institutional affiliations.

Printed on acid-free paper

This Springer imprint is published by Springer Nature

The registered company is Springer Nature Singapore Pte Ltd.

The registered company address is: 152 Beach Road, #21-01/04 Gateway East, Singapore 189721, Singapore

Preface

This AISC volume contains selected papers presented at the 10th International Conference on Advanced Computing and Communication Technologies (10th ICACCT 2016), technically sponsored by Institution of Electronics and Telecommunication Engineers (India), held during November 18–20, 2016 at Asia Pacific Institute of Information Technology, Panipat, India.

The technical program at 10th ICACCT 2016 featured inaugural addresses by Prof. Lalit M. Patnaik, National Institute of Advanced Studies, IISc, Bangalore and Mr. V. Ramagopal, Executive Director, Panipat Refinery and Petrochemicals, Indian Oil Corporation Ltd., Panipat; followed by six contributed paper sessions; Invited Paper Sessions and a valedictory session. The technical sessions were chaired by Prof. J.K. Mandal, Kalyani University; Prof. Dhananjay Bhattacharyya, Saha Institute of Nuclear Physics, Kolkata; Prof. Anu Mehra, AMITY University, Noida; Dr. Surya P. Singh, Indian Institute of Technology, Delhi; Mr. R. Ramamurthy, Dy. General Manager, Panipat Refinery and Petrochemicals, Indian Oil Corporation Ltd., Panipat; and Prof. Pradosh K. Roy, Asia Pacific Institute of Information Technology, Panipat.

Out of the contributed papers, 150 papers were shortlisted for second and third rounds of review by the expert panel after content evaluation and anti-plagiarism check using Turnitin®. After a rigorous review process, the final selection of 31 papers, corresponding to an acceptance rate of 20% was determined by these evaluation process. The selected papers cover a wide range of topics spanning theory, systems, applications, and case studies that could provide insights for using and enhancing advanced computing systems, communication technologies, services, and facilities.

A review of the state-of-the-art research work together with a discussion on CORDA as a computational model with reference to the problem of multi-robot area coverage has been enlightened in the invited paper.

The development of computational intelligence, it may be recalled, was inspired by observable and imitable aspects of intelligent activity of human being and nature. In the recent years, many hybrid techniques using the theories of computational intelligence are being applied in many fields of engineering and have many other practical implementations. Conforming to the theme of the conference, the

volume includes systems based on computational intelligence on data of various nature, e.g., text mining, image thresholding and encryption, target coverage and localization in wireless sensor networks, dynamic facility layout, human activity recognition, software defect prediction, interactive recommender system, genes mediating leukemia, and glaucoma diagnosis for retinal images. The other chapters relate to knowledge representation and deep learning, innovations in data encryption, reliability in MANET, active filters, innovative antenna design, micro electromechanical (MEM) systems design, quantum dot cellular automata, wave digital filters, heterogeneous distributed computing systems, big data analysis and a seminal paper on statistical machine translation of Bodo language.

We would like to thank members of the advisory and the program committee, especially Prof. Nikhil Ranjan Pal, Indian Statistical Institute, Calcutta; Prof. Subir Sarkar, Jadavpur University, Calcutta; Prof. Partha P. Bhattacharya, Mody University, Sikar, Rajasthan; Prof. Alok K. Rastogi, Institute for Excellence in Higher Education, Bhopal; Prof. Siddhartha Bhattacharya, RCC Institute of Information Technology, Calcutta; Prof. Bijay Baran Pal, University of Kalyani, West Bengal; Prof. R.R.K. Sharma, Indian Institute of Technology, Kanpur; Prof. Sarmistha Neogy, Jadavpur University, Calcutta; Dr. Nitin Auluck, IIT Ropar, Rupnagar; Dr. Surya Prakash Singh, Indian Institute of Technology, Delhi; Dr. Srabani Mukhopadhyaya, BIT Mesra Kolkata Extension Centre, Calcutta; Dr. Mahavir Jhavar, Ashoka University, Sonapat, Haryana; Dr. Tandra Pal, National Institute of Technology, Durgapur; Prof. Atul Sharma, Thapar University, Patiala; Prof. Moirangthem Marjit Singh, Northeast Regional Institute of Science and Technology, Itanagar, Arunachal Pradesh, for their enormous contributions towards the success of this conference. The authors of all contributed papers, the session chairs, and the session coordinators deserve our special thanks. We are thankful to the authors of the selected papers for suitably incorporating the modifications suggested by the reviewers and the session chairs in the scheduled time frame.

Acceptance of the proposal submitted to Springer Science+Business Media Singapore Pte. Ltd. for publication of the proceedings is gratefully acknowledged. We are grateful to the Institution of Electronics and Telecommunication Engineers (India) for technically sponsoring the conference. We are indebted to Mr. Aninda Bose, Senior Editor, Springer India Pvt. Ltd., New Delhi, for his valuable advice on similarity index and the review process. Financial support from Panipat Refinery and Petrochemicals, IOCL, India, in organizing the conference is gratefully acknowledged.

The Organizing Committee patronized by the Managing Committee of APIIT SD India, viz., Mr. Vinod Gupta, Chairman; Mr. Umesh Aggarwal, Vice Chairman; and Mr. Shrawan Mittal, Auditor; supervised by Prof. Virendra K. Srivastava and the Convener, Prof. Sachin Jasuja did a wonderful job in coordinating various activities.

It is our duty to acknowledge the inspiring guidance of Conference General Chair, Prof. Lalit M. Patnaik, Adjunct Professor, National Institute of Advanced Studies, Indian Institute of Science, Bangalore, India, in maintaining the high standards of the conference.

We would also like to thank the student volunteers for their unforgettable, tireless, and diligent efforts.

We hope the proceedings will inspire more research in computation, communication technologies particularly in computational intelligence and metaheuristic algorithms, in the near future.

Panipat, India
Kalyani, India
Kolkata, India
December 2016

Ramesh K. Choudhary
Jyotsna Kumar Mandal
Dhananjay Bhattacharyya

Conference Organization

Conference General Chair

Lalit M. Patnaik,

*INSA Senior Scientist and Adjunct Professor, Consciousness Studies Program,
National Institute of Advanced Studies, IISc Campus, Bangalore, 560012 India*

Advisory Committee

Nikhil Ranjan Pal, Indian Statistical Institute, Calcutta, India

Pradeep K. Sinha, International Institute of Information Technology, Naya Raipur,
India

Smt. Smriti Dagur, Institution of Electronics and Telecommunication Engineers,
New Delhi, India

Subir Sarkar, Jadavpur University, Calcutta, India

H.A. Nagarajaram, Centre of Computational Biology, CDFD Hyderabad, India

N. Seetharamakrishna, Intel India Pvt. Ltd. Bangalore, India

P.N. Vinaychandran, Indian Institute of Science, Bangalore, India

Anthony Atkins, Staffordshire University, UK

Adrian Low, Staffordshire University, UK

Subhansu Bandopadhyay, University of Calcutta, Calcutta, India

KTV Reddy, Institution of Electronics and Telecommunication Engineers, India

Raes Ahmed Khan, B.R. Ambedkar University, Lucknow, India

Manish Bali, NVIDIA Graphics Pvt. Ltd., Bangalore, India

Cai Wen, Guandong University of Technology, China

Yang Chunyan, Chinese Association of AI, China

Li Xingsen, Nigbo Institute of Technology, China

Adrian Olaru, University Politehnica of Baucharest, Romania

Nicole Pop, Universitatea Tehnica, Romania

Luige Vladareanu, Romanian Academy, Institute of Solid Mechanics, Romania
 Andy Seddon, APIIT Malaysia, Kuala Lumpur, Malaysia
 S. Venkatraman, University of Ballarat, Australia
 Yashwant K. Malaiya, Colorado State University, USA
 Ajay Kumar, Purnima University, Jaipur, India
 B.S. Bodla, IMS, Kurukshetra University, India
 Dinesh Khanduja, National Institute of Technology, Kurukshetra, India
 Rachit Garg, Lovely Professional University, Phagwara, India
 Sawtantar Singh, B.M. Singh College of Engineering, Muksar, Punjab, India
 Ekta Walia, South Asian University, New Delhi, India
 E.G. Rajan, Pentagram Research Centre, Hyderabad, India
 Pradosh K. Roy, Asia Pacific Institute of Information Technology, Panipat, India

Editorial Board

Ramesh K. Choudhary, Asia Pacific Institute of Information Technology, Panipat, India
 Jyotsna K. Mandal, University of Kalyani, Kalyani, India
 Dhananjay Bhattacharyya, Saha Institute of Nuclear Physics, Department of Atomic Energy, Calcutta, India

Technical Program Committee

A. Mondal, Burdwan University, Burdwan, India
 A.K. Bhattacharya, National Institute of Technology, Durgapur
 A.K. Mittal, NetajiSubhas Institute of Technology, Delhi, India
 Ajanta Das, BIT Mesra Kolkata Extension Centre, Kolkata, India
 Akhilesh Swaroop, National Institute of Technology, Kurukshetra, India
 Akhilesh Tiwari, Madhav Institute of Technology and Science, Gwalior, India
 Akhilesh Upadhyay, Sagar Institute of Research, Technology and Science, Bhopal
 Alamgir Hossain, University of Northumbria at Newcastle, UK
 Alok K. Rastogi, Institute for Excellence in Higher Education, Bhopal, India
 Ambar Dutta, BIT Mesra Kolkata Extension Centre, Kolkata, India
 Animesh Ray, Keck Graduate Institute, California, US
 Anirban Mukhopadhyay, Kalyani University, Kalyani, India
 B.K. Tripathy, Vellore Institute of Technology, Vellore, India
 B. Basu, OPSIS System, Sector V, Salt Lake, Kolkata, India
 B.B. Goyal, University Business School, Punjab University, Chandigarh, India
 B.K. Dey, Tripura University, Agartala, India
 Balaram Bhattacharya, VishvaBharati, Shantiniketan, India

Bijay Baran Pal, Kalyani University, Kalyani, India
 Brahmjeet Singh, National Institute of Technology, Kurukshetra, India
 C. Rosen, University of Derby, Derby, UK
 Chandreyee Chowdhury, Jadavpur University, Calcutta, India
 Cheki Dorji, Royal University of Bhutan, Bhutan
 Chowdhury Mofizur Rahman, United International University, Dhaka
 D.K. Pratihari, Indian Institute of Technology, Kharagpur, India
 D. Garg, Thapar University, Patiala, India
 D.D. Sinha, University of Kolkata, Kolkata, India
 Debasish Jana, TEOCO Software Pvt. Limited, Kolkata, India
 Deepanwita Das, National Institute of Technology, Durgapur, India
 Dhananjay Kulkarni, APIIT, Sri Lanka
 Ingrid Rugge, University of Bremen, Germany
 J.P. Choudhury, Kalyani Government Engineering College, India
 Jaya Sil, Indian Institute of Engineering Science and Technology, Shibpur, India
 Justin Champion, Staffordshire University, UK
 K. Dasgupta, Kalyani Government Engineering College, India
 K.R. Parpasani, M.A. National Institute of Technology, Bhopal, India
 Kalyani Mali, University of Kalyani, Kalyani, India
 Kanwalvir Singh Dhindsa, B.B.S.B. Engineering College, Punjab, India
 Krishnendu Mukhopadhyay, Indian Statistical Institute, Calcutta, India
 M. Sandirigam, University of Peradeniya, Peradeniya, Sri Lanka
 M.K. Bhowmik, Tripura University, Agartala, India
 M.K. Naskar, Jadavpur University, Kolkata, India
 Mahavir Jhawar, Ashoka University, Murthal, India
 Matteo Savino, University of Sannio, Italy
 Md.U. Bokhari, Aligarh Muslim University, Aligarh, India
 Meenakshi Suza, Indian Institute of Information Technology, Bangalore, India
 N.R. Manna, North Bengal University, Siliguri, India
 Nitin Auluck, Indian Institute of Technology Ropar, Rupnagar, India
 P. Jha, Indian School of Mines, Dhanbad, India
 P.K. Jana, North Bengal University, Siliguri, India
 P.P. Sarkar, Purbanchal University, Koshi, Nepal
 Paramartha Dutta, Visvabharati University, Shantiniketan, India
 Partha P. Bhattacharya, Mody University, Sikar, India
 Partha S. Mandal, Indian Institute of Technology, Guwahati, India
 Pitipong Yodmongkon, Chiang Mai University, Thailand
 R.K. Jena, Institute of Management Technology, Nagpur, India
 R.K. Samanta, North Bengal University, Siliguri, India
 Rajendra Sahu, IIT, Hyderabad, India
 Rajib K. Das, University of Calcutta, Kolkata, India
 Rameshwar Rijal, Kantipur Engineering College, Nepal
 Rohit Kamal Chatterjee, BITMesra, Kolkata Extension Centre, Kolkata, India
 S. Dutta, B.C. Roy Engineering College, Durgapur, India
 S. Mal, Kalyani Government Engineering College, India

S. Mukherjee, Burdwan University, Burdwan, India
 S. Muttoo, Delhi University, Delhi, India
 S. Shakya, Tribhuvan University, Nepal
 S.K. Mondal, Kalyani Government Engineering College, India
 Sarmishtha Neogy, Jadavpur University, Kolkata, India
 Sergei Silvestrov, Mälardalen University, Sweden
 Shankar Duraikannan, APIIT Kualalumpur, Malaysia
 Shuang Cang, Bournemouth University, UK
 Siddhartha Bhattachryya, RCC Institute of Information Technology, Calcutta, India
 Srabani Mukhopadhyaya, BIT Kolkata Campus, Kolkata, India
 Subhamoy Changder, National Institute of Technology, Durgapur, India
 Sudip Roy, Shell Technology Centre, Bangalore, India
 Surya P. Singh, Indian Institute of Technology, New Delhi, India
 Szabo Zoltan, Corvinus University of Budapest, Hungary
 Tandra Pal, National Institute of Technology, Durgapur, India
 Teresa Goncalves, Universidade de Évora, Portugal
 Trupti R. Lenka, National Institute of Technology, Silchar, India
 Ujjal Maulik, Jadavpur University, Calcutta, India
 Utpal Sharma, Tezpur University, Tezpur, India
 Vinay G. Vaidya, KPIT Technologies Ltd., Pune, India
 Virendra K. Srivastava, Asia Pacific Institute of Information Technology, Panipat, India
 Yacine Ouzrout, Université Lumiere Lyon2, France

Reviewers

Ajanta Das, BIT Mesra Kolkata Extension Centre, Kolkata, India
 Akash K. Tayal, I G Delhi Technical University for Women, New Delhi, India
 Alok K. Rastogi, Institute for Excellence in Higher Education, Bhopal, India
 Ambar Dutta, BIT Mesra Kolkata Extension Centre, Kolkata, India
 Animesh Ray, Keck Graduate Institute, California, US
 B.K. Tripathy, Vellore Institute of Technology, Vellore, India
 Bijay Baran Pal, University of Kalyani, Kalyani, India
 Chandreyee Chowdhury, Jadavpur University, Calcutta, India
 D.K. Pratihari, Indian Institute of Technology, Kharagpur, India
 Debasish Jana, TEOCO Software Pvt. Limited, Kolkata, India
 Deepanwita Das, National Institute of Technology, Durgapur, India
 Dhananjay Bhattacharyya, Saha Institute of Nuclear Physics, Calcutta, India
 Himadri Sekhar Dutta, Kalyani Government Engineering College, Kalyani, India
 Justin Champion, Staffordshire University, UK
 Jyotsna K. Mandal, University of Kalyani, Kalyani, India
 Krishnendu Mukhopadhyaya, Indian Statistical Institute, Calcutta, India

Madhurima Chattopadhyay, Heritage Institute of Technology, Calcutta, India
Mahavir Jhwar, Ashoka University, Sonapat, India
Nitinand Auluck, Indian Institute of Technology Ropar, Rupnagar, India
Paramartha Dutta, Visvabharati University; Shantiniketan, India
Partha P. Bhattacharya, College of Engineering and Technology, Mody University, Sikar, India
Partha Sarathi Mandal, Indian Institute of Technology, Guwahati, India
Pradosh K. Roy, Asia Pacific Institute of Information Technology, Panipat, India
R.K. Amit, Indian Institute of Technology, Madras, India
R.R.K. Sharma, Indian Institute of Technology, Kanpur, India
Rajib K. Das, University of Calcutta, Kolkata, India
Rohit Kamal Chatterjee, BIT Mesra Kolkata Extension Centre, Kolkata, India
Sarvani Roy, Jadavpur University, Calcutta, India
Sarmishtha Neogy, Jadavpur University, Calcutta, India
Siddhartha Bhattacharyya, RCC Institute of Information Technology, Calcutta, India
Somnath Mukherjee, Calcutta Business School, Calcutta, India
Srabani Mukhopadhyaya, BIT Mesra Kolkata Extension Centre, Calcutta, India
Subhamoy Changder, National Institute of Technology, Durgapur, India
Subho Chaudhuri, BIT Mesra Kolkata Extension Centre, Kolkata, India
Subir Sarkar, Jadavpur University, Calcutta, India
Sumer Singh, Indian Institute of Technology, Delhi, India
Sunandan Sen, University of Calcutta, India
Surya P. Singh, Indian Institute of Technology, New Delhi, India
Tandra Pal, National Institute of Technology, Durgapur, India
Ujjal Maulik, Jadavpur University, Calcutta, India
Utpal Biswas, Kalyani University, Kalyani, India
Utpal Sharma, Tezpur University, Tezpur

Organizing Committee

Patrons

Vinod Gupta

Chairman, Asia Pacific Institute of Information Technology, Panipat

Umesh Aggarwal

Vice Chairman, Asia Pacific Institute of Information Technology, Panipat

Shrawan Mittal

Aiditor, Asia Pacific Institute of Information Technology, Panipat

Convener

Sachin Jasuja, Department of Mechatronics and EE Engineering, APIIT, Panipat

Session Coordinators

Arun K. Choudhary, Department of Computer Science and Engineering, APIIT, Panipat

Geeta Nagpal, Department of Computer Science and Engineering, APIIT, Panipat

Gaurav Gambhir, Department of Computer Science and Engineering, APIIT, Panipat

Shipra Chaudhuri, Department of Management, APIIT, Panipat

Pradeep Singla, Department of Electronics Engineering, APIIT, Panipat

Mahima Goel, Department of Electronics Engineering, APIIT, Panipat

Parveen Kumar, Sanjeev Sharma (Technical Support)

Sponsorship and Finance

Shipra Chaudhuri, Department of Management, APIIT, Panipat

Sanjeev Jawa, Department of Finance and Accounting, APIIT, Panipat

Website Management

Sachin Jain, Multi Media Management Unit, APIIT, Panipat

Registration

Rajesh Tiwari, Department of Management, APIIT, Panipat

Virender Mehla, Department of Electronics Engineering, APIIT, Panipat

Geetanjali, Librarian, APIIT, Panipat

Priyanka Sachdeva, Department of Computer Science and Engineering, APIIT, Panipat

Hospitality, Transport, Accommodation

Pardeep Singla, Department of Electronics Engineering, APIIT, Panipat

Afzal Khan, Administrative Officer, APIIT, Panipat

Inventory in Charge

Arun Choudhary, Department of Computer Science and Engineering, APIIT, Panipat

Rajesh Tiwari, Department of Management, APIIT, Panipat

Rajender Khurana, Material Management Unit, APIIT, Panipat

Message from the General Chair

The 10th International Conference on Advanced Computing and Communication Technologies (10th ICACCT 2016) organized by the Asia Pacific Institute of Information Technology (APIIT) at Panipat during November 18–20, 2016 was primarily aimed at promoting early research on a wide range of topics in computing systems, communication technologies, and facilities. Theories of computational intelligence, it may be recalled, are being applied in many fields of science and engineering and have many other practical implementations. Therefore, the conference also aimed to enable collaborative efforts among researchers with different expertise and backgrounds.

The accepted papers were subjected to pre- and post-presentation plagiarism check and technical review. To ensure that the similarity percentage is consistently maintained within permissible limits, final versions of papers to appear in the proceedings volume were again subjected to similarity index check by Springer independently.

The Editorial Board, Advisory and Program Committee members, reviewers, invited speakers, session chairs, session coordinators, and student volunteers have done their jobs excellently towards the success of the technical program.

As General Chair of Conference, I convey my profuse thanks to Prof. Virendra K. Srivastava for providing all the excellent support from the APIIT SD India Management, which has been very generous in strongly encouraging this Conference. I would like to thank Prof. Nikhil R. Pal, Indian Statistical Institute, Calcutta; Prof. Jyotsna K. Mandal, Kalyani University; Prof. Dhananjay Bhattacharyya, Saha Institute of Nuclear Physics; Prof. Subir Sarkar, Jadavpur University; Prof. Partha P. Bhattacharya, Mody University, Sikar; Prof. Alok K. Rastogi, Institute for Excellence in Higher Education, Bhopal; Dr. Srabani Mukhopadhyay, BIT Mesra, Kolkata Extension Centre; Prof. Sarmistha Neogy, Jadavpur University; Prof. Siddhartha Bhattacharya, RCC Institute of Information Technology, Calcutta; Dr. Nitin Auluck, IIT Ropar, Rupnagar; Dr. Surya P. Singh, IIT Delhi; Prof. Atul Sharma, Thapar University, Patiala; Prof. Marjit M. Singh, NERIST, Itanagar for their valuable time and efforts in organizing the conference

successfully. Finally, my special appreciation goes to Mr. Aninda Bose, Senior Editor, Springer India Pvt. Ltd., New Delhi for his advice.

We are grateful to the Institution of Electronics and Telecommunication Engineers for being the technical sponsors and Panipat Refinery and Petrochemicals, Indian Oil Corporation Ltd., Panipat, for partial financial support.

I am sure this volume will be indispensable for the researchers engaged in computing and communication technologies.

Bangalore, India
December 2016

Lalit M. Patnaik
INSA Senior Scientist and Adjunct Professor
Conference General Chair, 10th ICACCT 2016
Consciousness Studies Program
www.lmpatnaik.in

Contents

Part I Advanced Computing: Computational Intelligence	
Suitability of CORDA Model for Area Coverage Problem	3
Deepanwita Das and Srabani Mukhopadhyaya	
A Hybrid of Fireworks and Harmony Search Algorithm for Multilevel Image Thresholding	11
Shivali, Lalit Maurya, Ekta Sharma, Prasant Mahapatra and Amit Doegar	
Performance Evaluation of New Text Mining Method Based on GA and K-Means Clustering Algorithm	23
Neha Garg and R.K. Gupta	
Modeling Stochastic Dynamic Facility Layout Using Hybrid Fireworks Algorithm and Chaotic Simulated Annealing: A Case of Indian Garment Industry	31
Akash Tayal and Surya Prakash Singh	
Transition-Aware Human Activity Recognition Using eXtreme Gradient Boosted Decision Trees	41
Kunal Gusain, Aditya Gupta and Bhavya Popli	
Software Defect Prediction: A Comparison Between Artificial Neural Network and Support Vector Machine	51
Ishani Arora and Anju Saha	
Random Selection of Crossover Operation with Mutation for Image Encryption—A New Approach	63
Jalesh Kumar and S. Nirmala	
User-Interactive Recommender System for Electronic Products Using Fuzzy Numbers	73
Shalini Sharma, C. Rama Krishna, Shano Solanki, Khushleen Kaur and Sharandeep Kaur	

Selection of Genes Mediating Human Leukemia, Using Boltzmann Machine	83
Sougata Sheet, Anupam Ghosh and Sudhindu Bikash Mandal	
Survey of Classification Approaches for Glaucoma Diagnosis from Retinal Images	91
Niharika Thakur and Mamta Juneja	
Discovering Optimal Patterns for Forensic Pattern Warehouse	101
Vishakha Agarwal, Akhilesh Tiwari, R.K. Gupta and Uday Pratap Singh	
Part II Advanced Computing: Distributed Computing	
Comparative Study of Scheduling Algorithms in Heterogeneous Distributed Computing Systems	111
Mamta Padole and Ankit Shah	
Part III Advanced Computing: Knowledge Representation	
Knowledge Reasoning for Decision Support (KRDS) in Healthcare Environment	125
Nawaf Alharbe, Lizong Zhang and Anthony S. Atkins	
Object Detection from Video Sequences Using Deep Learning: An Overview	137
Dweepna Garg and Ketan Kotecha	
A Framework for Improved Cooperative Learning Algorithms with Expertness (ICLAE)	149
Deepak A. Vidhate and Parag Kulkarni	
Part IV Advanced Computing: Data Encryption	
Bicubic Interpolation Based Audio Authentication (BIAA)	163
Uttam Kr. Mondal and Jyotsna Kumar Mandal	
Hierarchical Metadata-Based Secure Data Retrieval Technique for Healthcare Application	175
Sayantani Saha, Priyanka Saha and Sarmistha Neogy	
Intelligent Multiple Watermarking Schemes for the Authentication and Tamper Recovery of Information in Document Image	183
K.R. Chetan and S. Nirmala	
Part V Advanced Computing: Big Data	
Research of Access Optimization of Small Files on Basis of B + Tree on Hadoop	197
Yan Wang, YuQiang Li, YuWen Li, Yilong Shi and Weiwei Li	

Part VI Advanced Computing: Machine Translation

English to Bodo Phrase-Based Statistical Machine Translation 207
 Md. Saiful Islam and Bipul Syam Purkayastha

Part VII Advanced Computing: Case Study

Modelling Sustainable Procurement: A Case of Indian Manufacturing Firm 221
 Harpreet Kaur and Surya Prakash Singh

Part VIII Advanced Computing: Miscellaneous—Social Networks

Key Author Analysis in Research Professionals’ Collaboration Network Based on Collaborative Index 233
 Anand Bihari and Sudhakar Tripathi

Part IX Communication Technologies

Localization in Wireless Sensor Networks Using Invasive Weed Optimization Based on Fuzzy Logic System 245
 Gaurav Sharma, Ashok Kumar, Prabhleen Singh and Mohammad Jibran Hafeez

Genetic Algorithm-Based Heuristic for Solving Target Coverage Problem in Wireless Sensor Networks 257
 Manju, Deepti Singh, Satish Chand and Bijendra Kumar

Target Coverage Heuristics in Wireless Sensor Networks 265
 Manju, Deepti Singh, Satish Chand and Bijendra Kumar

Effect of Black Hole Attack on MANET Reliability in DSR Routing Protocol 275
 Moirangthem Marjit Singh and Jyotsna Kumar Mandal

Part X Microelectronics and Antenna Design

Noise Performance and Design Optimization of a Piezoresistive MEMS Accelerometer Used in a Strapdown Medical Diagnostic System 287
 Sonali Biswas and Anup Kumar Gogoi

Current Mode Universal Filter Realization Employing CCIII and OTA-A Minimal Realization 297
 Tajinder Singh Arora

On the Design of Hexagon-Slotted Circular Fractal Antenna for C Band Applications 307
 Harpreet Kaur and Jagtar Singh

An Efficient Single-Layer Crossing Based 4-Bit Shift Register Using QCA 315
Trailokya Nath Sasamal, Ashutosh Kumar Singh and Umesh Ghanekar

Wave Digital Realization of Current Conveyor Family 327
Richa Barsainya, Tarun Kumar Rawat and Rachit Mahendra

Author Index. 335

About the Editors

Ramesh K. Choudhary, former Director, Asia Pacific Institute of Information Technology, Panipat, obtained Ph.D. from VMU, Salem, has co-authored ‘Testing of Fault Tolerance Techniques’ published by Lambert Academic Publishing, Germany. He was the Indian Coordinator, Featured Europe and South Asia MObility Network (FUSION), an ERUSMUS MUNDUS (EU) project to foster partnerships of emerging Asian countries with the EU countries reinforcing the existing collaborations developed through the EU funded projects. He had also significantly contributed to the EU-ASIA mutual recognition of studies in engineering, management, and informatics. He is Fellow of Institution of Engineers (India), IETE, and Members of IEEE, ACM, and Chinese Association for Artificial Intelligence.

Jyotsna Kumar Mandal, former Dean, Faculty of Engineering, Technology and Management, is Senior Professor, Department of Computer Science and Engineering, University of Kalyani, India. He has obtained Ph.D. (Engg.) from Jadavpur University. Professor Mandal has co-authored six books, viz., Algorithmic Design of Compression Schemes and Correction Techniques—A Practical Approach; Symmetric Encryption—Algorithm, Analysis and Applications: Low Cost-based Security; Steganographic Techniques and Application in Document Authentication—An Algorithmic Approach; Optimization-based Filtering of Random Valued Impulses—An Algorithmic Approach; and Artificial Neural Network Guided Secured Communication Techniques: A Practical Approach; all published by Lambert Academic Publishing, Germany. He has authored more than 350 papers on a wide range of topics in international journals and proceedings. His profile is included in the 31st edition of Marque’s World Who’s Who published in 2013. His areas of research include coding theory, data and network security, remote sensing and GIS-based applications, data compression, error correction, visual cryptography and steganography, distributed and shared memory parallel programming. He is Fellow of Institution of Electronics and Telecommunication Engineers, and Members of IEEE, ACM, and Computer Society of India.

Dhananjay Bhattacharyya, Head of Computer Sciences Division, Saha Institute of Nuclear Physics, Calcutta, India, obtained Ph.D. from Indian Institute of Science, Bangalore, and is a postdoctoral fellow from National Institutes of Health, Bethesda, Maryland, USA. Dr. Bhattacharyya's research interest is in understanding structure–function relationship of biological macromolecules, particularly nucleic acids. In this context, he utilizes available crystallographic data to carry out molecular dynamics simulation and ab initio quantum chemical calculations to understand structural stabilization of nucleic acid bases and recognition of nucleic acid by other ligands. In order to understand different structural features of nucleic acids, the CS division at Saha Institute of Nuclear Physics has developed few software tools under his guidance, such as NUPARM, BPFIND, PyrHB Find, etc. Using some of these tools, the CS division has classified structures of different non-canonical base pairs appearing in RNA crystal structures. Dr. Bhattacharyya has successfully guided several doctoral candidates on computational biology and bioinformatics.

Ramesh K. Choudhary
Jyotsna Kumar Mandal
Dhananjay Bhattacharyya *Editors*

Advanced Computing and Communication Technologies

Proceedings of the 10th ICACCT, 2016

Advances in Intelligent Systems and Computing

Volume 562

Series editor

Janusz Kacprzyk, Polish Academy of Sciences, Warsaw, Poland
e-mail: kacprzyk@ibspan.waw.pl

About this Series

The series “Advances in Intelligent Systems and Computing” contains publications on theory, applications, and design methods of Intelligent Systems and Intelligent Computing. Virtually all disciplines such as engineering, natural sciences, computer and information science, ICT, economics, business, e-commerce, environment, healthcare, life science are covered. The list of topics spans all the areas of modern intelligent systems and computing.

The publications within “Advances in Intelligent Systems and Computing” are primarily textbooks and proceedings of important conferences, symposia and congresses. They cover significant recent developments in the field, both of a foundational and applicable character. An important characteristic feature of the series is the short publication time and world-wide distribution. This permits a rapid and broad dissemination of research results.

Advisory Board

Chairman

Nikhil R. Pal, Indian Statistical Institute, Kolkata, India

e-mail: nikhil@isical.ac.in

Members

Rafael Bello Perez, Universidad Central “Marta Abreu” de Las Villas, Santa Clara, Cuba

e-mail: rbellop@uclv.edu.cu

Emilio S. Corchado, University of Salamanca, Salamanca, Spain

e-mail: escorchado@usal.es

Hani Hagrass, University of Essex, Colchester, UK

e-mail: hani@essex.ac.uk

László T. Kóczy, Széchenyi István University, Győr, Hungary

e-mail: koczy@sze.hu

Vladik Kreinovich, University of Texas at El Paso, El Paso, USA

e-mail: vladik@utep.edu

Chin-Teng Lin, National Chiao Tung University, Hsinchu, Taiwan

e-mail: ctlin@mail.nctu.edu.tw

Jie Lu, University of Technology, Sydney, Australia

e-mail: Jie.Lu@uts.edu.au

Patricia Melin, Tijuana Institute of Technology, Tijuana, Mexico

e-mail: epmelin@hafsamx.org

Nadia Nedjah, State University of Rio de Janeiro, Rio de Janeiro, Brazil

e-mail: nadia@eng.uerj.br

Ngoc Thanh Nguyen, Wroclaw University of Technology, Wroclaw, Poland

e-mail: Ngoc-Thanh.Nguyen@pwr.edu.pl

Jun Wang, The Chinese University of Hong Kong, Shatin, Hong Kong

e-mail: jwang@mae.cuhk.edu.hk

More information about this series at <http://www.springer.com/series/11156>

Ramesh K. Choudhary · Jyotsna Kumar Mandal
Dhananjay Bhattacharyya
Editors

Advanced Computing and Communication Technologies

Proceedings of the 10th ICACCT, 2016

 Springer

Editors

Ramesh K. Choudhary
Asia Pacific Institute of Information
Technology
Panipat, Haryana
India

Dhananjay Bhattacharyya
Computational Science Division
Saha Institute of Nuclear Physics
Kolkata, West Bengal
India

Jyotsna Kumar Mandal
Department of Computer Science
and Engineering
Faculty of Engineering, Technology
and Management
Kalyani University
Kalyani, West Bengal
India

ISSN 2194-5357

ISSN 2194-5365 (electronic)

Advances in Intelligent Systems and Computing

ISBN 978-981-10-4602-5

ISBN 978-981-10-4603-2 (eBook)

<https://doi.org/10.1007/978-981-10-4603-2>

Library of Congress Control Number: 2017940607

© Springer Nature Singapore Pte Ltd. 2018

This work is subject to copyright. All rights are reserved by the Publisher, whether the whole or part of the material is concerned, specifically the rights of translation, reprinting, reuse of illustrations, recitation, broadcasting, reproduction on microfilms or in any other physical way, and transmission or information storage and retrieval, electronic adaptation, computer software, or by similar or dissimilar methodology now known or hereafter developed.

The use of general descriptive names, registered names, trademarks, service marks, etc. in this publication does not imply, even in the absence of a specific statement, that such names are exempt from the relevant protective laws and regulations and therefore free for general use.

The publisher, the authors and the editors are safe to assume that the advice and information in this book are believed to be true and accurate at the date of publication. Neither the publisher nor the authors or the editors give a warranty, express or implied, with respect to the material contained herein or for any errors or omissions that may have been made. The publisher remains neutral with regard to jurisdictional claims in published maps and institutional affiliations.

Printed on acid-free paper

This Springer imprint is published by Springer Nature

The registered company is Springer Nature Singapore Pte Ltd.

The registered company address is: 152 Beach Road, #21-01/04 Gateway East, Singapore 189721, Singapore

Preface

This AISC volume contains selected papers presented at the 10th International Conference on Advanced Computing and Communication Technologies (10th ICACCT 2016), technically sponsored by Institution of Electronics and Telecommunication Engineers (India), held during November 18–20, 2016 at Asia Pacific Institute of Information Technology, Panipat, India.

The technical program at 10th ICACCT 2016 featured inaugural addresses by Prof. Lalit M. Patnaik, National Institute of Advanced Studies, IISc, Bangalore and Mr. V. Ramagopal, Executive Director, Panipat Refinery and Petrochemicals, Indian Oil Corporation Ltd., Panipat; followed by six contributed paper sessions; Invited Paper Sessions and a valedictory session. The technical sessions were chaired by Prof. J.K. Mandal, Kalyani University; Prof. Dhananjay Bhattacharyya, Saha Institute of Nuclear Physics, Kolkata; Prof. Anu Mehra, AMITY University, Noida; Dr. Surya P. Singh, Indian Institute of Technology, Delhi; Mr. R. Ramamurthy, Dy. General Manager, Panipat Refinery and Petrochemicals, Indian Oil Corporation Ltd., Panipat; and Prof. Pradosh K. Roy, Asia Pacific Institute of Information Technology, Panipat.

Out of the contributed papers, 150 papers were shortlisted for second and third rounds of review by the expert panel after content evaluation and anti-plagiarism check using Turnitin®. After a rigorous review process, the final selection of 31 papers, corresponding to an acceptance rate of 20% was determined by these evaluation process. The selected papers cover a wide range of topics spanning theory, systems, applications, and case studies that could provide insights for using and enhancing advanced computing systems, communication technologies, services, and facilities.

A review of the state-of-the-art research work together with a discussion on CORDA as a computational model with reference to the problem of multi-robot area coverage has been enlightened in the invited paper.

The development of computational intelligence, it may be recalled, was inspired by observable and imitable aspects of intelligent activity of human being and nature. In the recent years, many hybrid techniques using the theories of computational intelligence are being applied in many fields of engineering and have many other practical implementations. Conforming to the theme of the conference, the

volume includes systems based on computational intelligence on data of various nature, e.g., text mining, image thresholding and encryption, target coverage and localization in wireless sensor networks, dynamic facility layout, human activity recognition, software defect prediction, interactive recommender system, genes mediating leukemia, and glaucoma diagnosis for retinal images. The other chapters relate to knowledge representation and deep learning, innovations in data encryption, reliability in MANET, active filters, innovative antenna design, micro electromechanical (MEM) systems design, quantum dot cellular automata, wave digital filters, heterogeneous distributed computing systems, big data analysis and a seminal paper on statistical machine translation of Bodo language.

We would like to thank members of the advisory and the program committee, especially Prof. Nikhil Ranjan Pal, Indian Statistical Institute, Calcutta; Prof. Subir Sarkar, Jadavpur University, Calcutta; Prof. Partha P. Bhattacharya, Mody University, Sikar, Rajasthan; Prof. Alok K. Rastogi, Institute for Excellence in Higher Education, Bhopal; Prof. Siddhartha Bhattacharya, RCC Institute of Information Technology, Calcutta; Prof. Bijay Baran Pal, University of Kalyani, West Bengal; Prof. R.R.K. Sharma, Indian Institute of Technology, Kanpur; Prof. Sarmistha Neogy, Jadavpur University, Calcutta; Dr. Nitin Auluck, IIT Ropar, Rupnagar; Dr. Surya Prakash Singh, Indian Institute of Technology, Delhi; Dr. Srabani Mukhopadhyaya, BIT Mesra Kolkata Extension Centre, Calcutta; Dr. Mahavir Jhavar, Ashoka University, Sonapat, Haryana; Dr. Tandra Pal, National Institute of Technology, Durgapur; Prof. Atul Sharma, Thapar University, Patiala; Prof. Moirangthem Marjit Singh, Northeast Regional Institute of Science and Technology, Itanagar, Arunachal Pradesh, for their enormous contributions towards the success of this conference. The authors of all contributed papers, the session chairs, and the session coordinators deserve our special thanks. We are thankful to the authors of the selected papers for suitably incorporating the modifications suggested by the reviewers and the session chairs in the scheduled time frame.

Acceptance of the proposal submitted to Springer Science+Business Media Singapore Pte. Ltd. for publication of the proceedings is gratefully acknowledged. We are grateful to the Institution of Electronics and Telecommunication Engineers (India) for technically sponsoring the conference. We are indebted to Mr. Aninda Bose, Senior Editor, Springer India Pvt. Ltd., New Delhi, for his valuable advice on similarity index and the review process. Financial support from Panipat Refinery and Petrochemicals, IOCL, India, in organizing the conference is gratefully acknowledged.

The Organizing Committee patronized by the Managing Committee of APIIT SD India, viz., Mr. Vinod Gupta, Chairman; Mr. Umesh Aggarwal, Vice Chairman; and Mr. Shrawan Mittal, Auditor; supervised by Prof. Virendra K. Srivastava and the Convener, Prof. Sachin Jasuja did a wonderful job in coordinating various activities.

It is our duty to acknowledge the inspiring guidance of Conference General Chair, Prof. Lalit M. Patnaik, Adjunct Professor, National Institute of Advanced Studies, Indian Institute of Science, Bangalore, India, in maintaining the high standards of the conference.

We would also like to thank the student volunteers for their unforgettable, tireless, and diligent efforts.

We hope the proceedings will inspire more research in computation, communication technologies particularly in computational intelligence and metaheuristic algorithms, in the near future.

Panipat, India
Kalyani, India
Kolkata, India
December 2016

Ramesh K. Choudhary
Jyotsna Kumar Mandal
Dhananjay Bhattacharyya

Conference Organization

Conference General Chair

Lalit M. Patnaik,

*INSA Senior Scientist and Adjunct Professor, Consciousness Studies Program,
National Institute of Advanced Studies, IISc Campus, Bangalore, 560012 India*

Advisory Committee

Nikhil Ranjan Pal, Indian Statistical Institute, Calcutta, India

Pradeep K. Sinha, International Institute of Information Technology, Naya Raipur,
India

Smt. Smriti Dagur, Institution of Electronics and Telecommunication Engineers,
New Delhi, India

Subir Sarkar, Jadavpur University, Calcutta, India

H.A. Nagarajaram, Centre of Computational Biology, CDFD Hyderabad, India

N. Seetharamakrishna, Intel India Pvt. Ltd. Bangalore, India

P.N. Vinaychandran, Indian Institute of Science, Bangalore, India

Anthony Atkins, Staffordshire University, UK

Adrian Low, Staffordshire University, UK

Subhansu Bandopadhyay, University of Calcutta, Calcutta, India

KTV Reddy, Institution of Electronics and Telecommunication Engineers, India

Raes Ahmed Khan, B.R. Ambedkar University, Lucknow, India

Manish Bali, NVIDIA Graphics Pvt. Ltd., Bangalore, India

Cai Wen, Guandong University of Technology, China

Yang Chunyan, Chinese Association of AI, China

Li Xingsen, Nigbo Institute of Technology, China

Adrian Olaru, University Politehnica of Baucharest, Romania

Nicole Pop, Universitatea Tehnica, Romania

Luige Vladareanu, Romanian Academy, Institute of Solid Mechanics, Romania
 Andy Seddon, APIIT Malaysia, Kuala Lumpur, Malaysia
 S. Venkatraman, University of Ballarat, Australia
 Yashwant K. Malaiya, Colarado State University, USA
 Ajay Kumar, Purnima University, Jaipur, India
 B.S. Bodla, IMS, Kurukshetra University, India
 Dinesh Khanduja, National Institute of Technology, Kurukshetra, India
 Rachit Garg, Lovely Professional University, Phagwara, India
 Sawtantar Singh, B.M. Singh College of Engineering, Muksar, Punjab, India
 Ekta Walia, South Asian University, New Delhi, India
 E.G. Rajan, Pentagram Research Centre, Hyderabad, India
 Pradosh K. Roy, Asia Pacific Institute of Information Technology, Panipat, India

Editorial Board

Ramesh K. Choudhary, Asia Pacific Institute of Information Technology, Panipat, India
 Jyotsna K. Mandal, University of Kalyani, Kalyani, India
 Dhananjay Bhattacharyya, Saha Institute of Nuclear Physics, Department of Atomic Energy, Calcutta, India

Technical Program Committee

A. Mondal, Burdwan University, Burdwan, India
 A.K. Bhattacharya, National Institute of Technology, Durgapur
 A.K. Mittal, NetajiSubhas Institute of Technology, Delhi, India
 Ajanta Das, BIT Mesra Kolkata Extension Centre, Kolkata, India
 Akhilesh Swaroop, National Institute of Technology, Kurukshetra, India
 Akhilesh Tiwari, Madhav Institute of Technology and Science, Gwalior, India
 Akhilesh Upadhyay, Sagar Institute of Research, Technology and Science, Bhopal
 Alamgir Hossain, University of Northumbria at Newcastle, UK
 Alok K. Rastogi, Institute for Excellence in Higher Education, Bhopal, India
 Ambar Dutta, BIT Mesra Kolkata Extension Centre, Kolkata, India
 Animesh Ray, Keck Graduate Institute, California, US
 Anirban Mukhopadhyay, Kalyani University, Kalyani, India
 B.K. Tripathy, Vellore Institute of Technology, Vellore, India
 B. Basu, OPSIS System, Sector V, Salt Lake, Kolkata, India
 B.B. Goyal, University Business School, Punjab University, Chandigarh, India
 B.K. Dey, Tripura University, Agartala, India
 Balaram Bhattacharya, VishvaBharati, Shantiniketan, India

Bijay Baran Pal, Kalyani University, Kalyani, India
 Brahmjeet Singh, National Institute of Technology, Kurukshetra, India
 C. Rosen, University of Derby, Derby, UK
 Chandreyee Chowdhury, Jadavpur University, Calcutta, India
 Cheki Dorji, Royal University of Bhutan, Bhutan
 Chowdhury Mofizur Rahman, United International University, Dhaka
 D.K. Pratihari, Indian Institute of Technology, Kharagpur, India
 D. Garg, Thapar University, Patiala, India
 D.D. Sinha, University of Kolkata, Kolkata, India
 Debasish Jana, TEOCO Software Pvt. Limited, Kolkata, India
 Deepanwita Das, National Institute of Technology, Durgapur, India
 Dhananjay Kulkarni, APIIT, Sri Lanka
 Ingrid Rugge, University of Bremen, Germany
 J.P. Choudhury, Kalyani Government Engineering College, India
 Jaya Sil, Indian Institute of Engineering Science and Technology, Shibpur, India
 Justin Champion, Staffordshire University, UK
 K. Dasgupta, Kalyani Government Engineering College, India
 K.R. Parpasani, M.A. National Institute of Technology, Bhopal, India
 Kalyani Mali, University of Kalyani, Kalyani, India
 Kanwalvir Singh Dhindsa, B.B.S.B. Engineering College, Punjab, India
 Krishnendu Mukhopadhyay, Indian Statistical Institute, Calcutta, India
 M. Sandirigam, University of Peradeniya, Peradeniya, Sri Lanka
 M.K. Bhowmik, Tripura University, Agartala, India
 M.K. Naskar, Jadavpur University, Kolkata, India
 Mahavir Jhawar, Ashoka University, Murthal, India
 Matteo Savino, University of Sannio, Italy
 Md.U. Bokhari, Aligarh Muslim University, Aligarh, India
 Meenakshi Suza, Indian Institute of Information Technology, Bangalore, India
 N.R. Manna, North Bengal University, Siliguri, India
 Nitin Auluck, Indian Institute of Technology Ropar, Rupnagar, India
 P. Jha, Indian School of Mines, Dhanbad, India
 P.K. Jana, North Bengal University, Siliguri, India
 P.P. Sarkar, Purbanchal University, Koshi, Nepal
 Paramartha Dutta, Visvabharati University, Shantiniketan, India
 Partha P. Bhattacharya, Mody University, Sikar, India
 Partha S. Mandal, Indian Institute of Technology, Guwahati, India
 Pitipong Yodmongkon, Chiang Mai University, Thailand
 R.K. Jena, Institute of Management Technology, Nagpur, India
 R.K. Samanta, North Bengal University, Siliguri, India
 Rajendra Sahu, IIT, Hyderabad, India
 Rajib K. Das, University of Calcutta, Kolkata, India
 Rameshwar Rijal, Kantipur Engineering College, Nepal
 Rohit Kamal Chatterjee, BITMesra, Kolkata Extension Centre, Kolkata, India
 S. Dutta, B.C. Roy Engineering College, Durgapur, India
 S. Mal, Kalyani Government Engineering College, India

S. Mukherjee, Burdwan University, Burdwan, India
 S. Muttoo, Delhi University, Delhi, India
 S. Shakya, Tribhuvan University, Nepal
 S.K. Mondal, Kalyani Government Engineering College, India
 Sarmishtha Neogy, Jadavpur University, Kolkata, India
 Sergei Silvestrov, Mälardalen University, Sweden
 Shankar Duraikannan, APIIT Kualalumpur, Malaysia
 Shuang Cang, Bournemouth University, UK
 Siddhartha Bhattachryya, RCC Institute of Information Technology, Calcutta, India
 Srabani Mukhopadhyaya, BIT Kolkata Campus, Kolkata, India
 Subhamoy Changder, National Institute of Technology, Durgapur, India
 Sudip Roy, Shell Technology Centre, Bangalore, India
 Surya P. Singh, Indian Institute of Technology, New Delhi, India
 Szabo Zoltan, Corvinus University of Budapest, Hungary
 Tandra Pal, National Institute of Technology, Durgapur, India
 Teresa Goncalves, Universidade de Évora, Portugal
 Trupti R. Lenka, National Institute of Technology, Silchar, India
 Ujjal Maulik, Jadavpur University, Calcutta, India
 Utpal Sharma, Tezpur University, Tezpur, India
 Vinay G. Vaidya, KPIT Technologies Ltd., Pune, India
 Virendra K. Srivastava, Asia Pacific Institute of Information Technology, Panipat, India
 Yacine Ouzrout, Université Lumiere Lyon2, France

Reviewers

Ajanta Das, BIT Mesra Kolkata Extension Centre, Kolkata, India
 Akash K. Tayal, I G Delhi Technical University for Women, New Delhi, India
 Alok K. Rastogi, Institute for Excellence in Higher Education, Bhopal, India
 Ambar Dutta, BIT Mesra Kolkata Extension Centre, Kolkata, India
 Animesh Ray, Keck Graduate Institute, California, US
 B.K. Tripathy, Vellore Institute of Technology, Vellore, India
 Bijay Baran Pal, University of Kalyani, Kalyani, India
 Chandreyee Chowdhury, Jadavpur University, Calcutta, India
 D.K. Pratihari, Indian Institute of Technology, Kharagpur, India
 Debasish Jana, TEOCO Software Pvt. Limited, Kolkata, India
 Deepanwita Das, National Institute of Technology, Durgapur, India
 Dhananjay Bhattacharyya, Saha Institute of Nuclear Physics, Calcutta, India
 Himadri Sekhar Dutta, Kalyani Government Engineering College, Kalyani, India
 Justin Champion, Staffordshire University, UK
 Jyotsna K. Mandal, University of Kalyani, Kalyani, India
 Krishnendu Mukhopadhyaya, Indian Statistical Institute, Calcutta, India

Madhurima Chattopadhyay, Heritage Institute of Technology, Calcutta, India
Mahavir Jhwar, Ashoka University, Sonapat, India
Nitinand Auluck, Indian Institute of Technology Ropar, Rupnagar, India
Paramartha Dutta, Visvabharati University; Shantiniketan, India
Partha P. Bhattacharya, College of Engineering and Technology, Mody University, Sikar, India
Partha Sarathi Mandal, Indian Institute of Technology, Guwahati, India
Pradosh K. Roy, Asia Pacific Institute of Information Technology, Panipat, India
R.K. Amit, Indian Institute of Technology, Madras, India
R.R.K. Sharma, Indian Institute of Technology, Kanpur, India
Rajib K. Das, University of Calcutta, Kolkata, India
Rohit Kamal Chatterjee, BIT Mesra Kolkata Extension Centre, Kolkata, India
Sarvani Roy, Jadavpur University, Calcutta, India
Sarmishtha Neogy, Jadavpur University, Calcutta, India
Siddhartha Bhattacharyya, RCC Institute of Information Technology, Calcutta, India
Somnath Mukherjee, Calcutta Business School, Calcutta, India
Srabani Mukhopadhyaya, BIT Mesra Kolkata Extension Centre, Calcutta, India
Subhamoy Changder, National Institute of Technology, Durgapur, India
Subho Chaudhuri, BIT Mesra Kolkata Extension Centre, Kolkata, India
Subir Sarkar, Jadavpur University, Calcutta, India
Sumer Singh, Indian Institute of Technology, Delhi, India
Sunandan Sen, University of Calcutta, India
Surya P. Singh, Indian Institute of Technology, New Delhi, India
Tandra Pal, National Institute of Technology, Durgapur, India
Ujjal Maulik, Jadavpur University, Calcutta, India
Utpal Biswas, Kalyani University, Kalyani, India
Utpal Sharma, Tezpur University, Tezpur

Organizing Committee

Patrons

Vinod Gupta

Chairman, Asia Pacific Institute of Information Technology, Panipat

Umesh Aggarwal

Vice Chairman, Asia Pacific Institute of Information Technology, Panipat

Shrawan Mittal

Aiditor, Asia Pacific Institute of Information Technology, Panipat

Convener

Sachin Jasuja, Department of Mechatronics and EE Engineering, APIIT, Panipat

Session Coordinators

Arun K. Choudhary, Department of Computer Science and Engineering, APIIT, Panipat

Geeta Nagpal, Department of Computer Science and Engineering, APIIT, Panipat

Gaurav Gambhir, Department of Computer Science and Engineering, APIIT, Panipat

Shipra Chaudhuri, Department of Management, APIIT, Panipat

Pradeep Singla, Department of Electronics Engineering, APIIT, Panipat

Mahima Goel, Department of Electronics Engineering, APIIT, Panipat

Parveen Kumar, Sanjeev Sharma (Technical Support)

Sponsorship and Finance

Shipra Chaudhuri, Department of Management, APIIT, Panipat

Sanjeev Jawa, Department of Finance and Accounting, APIIT, Panipat

Website Management

Sachin Jain, Multi Media Management Unit, APIIT, Panipat

Registration

Rajesh Tiwari, Department of Management, APIIT, Panipat

Virender Mehla, Department of Electronics Engineering, APIIT, Panipat

Geetanjali, Librarian, APIIT, Panipat

Priyanka Sachdeva, Department of Computer Science and Engineering, APIIT, Panipat

Hospitality, Transport, Accommodation

Pardeep Singla, Department of Electronics Engineering, APIIT, Panipat

Afzal Khan, Administrative Officer, APIIT, Panipat

Inventory in Charge

Arun Choudhary, Department of Computer Science and Engineering, APIIT, Panipat

Rajesh Tiwari, Department of Management, APIIT, Panipat

Rajender Khurana, Material Management Unit, APIIT, Panipat

Message from the General Chair

The 10th International Conference on Advanced Computing and Communication Technologies (10th ICACCT 2016) organized by the Asia Pacific Institute of Information Technology (APIIT) at Panipat during November 18–20, 2016 was primarily aimed at promoting early research on a wide range of topics in computing systems, communication technologies, and facilities. Theories of computational intelligence, it may be recalled, are being applied in many fields of science and engineering and have many other practical implementations. Therefore, the conference also aimed to enable collaborative efforts among researchers with different expertise and backgrounds.

The accepted papers were subjected to pre- and post-presentation plagiarism check and technical review. To ensure that the similarity percentage is consistently maintained within permissible limits, final versions of papers to appear in the proceedings volume were again subjected to similarity index check by Springer independently.

The Editorial Board, Advisory and Program Committee members, reviewers, invited speakers, session chairs, session coordinators, and student volunteers have done their jobs excellently towards the success of the technical program.

As General Chair of Conference, I convey my profuse thanks to Prof. Virendra K. Srivastava for providing all the excellent support from the APIIT SD India Management, which has been very generous in strongly encouraging this Conference. I would like to thank Prof. Nikhil R. Pal, Indian Statistical Institute, Calcutta; Prof. Jyotsna K. Mandal, Kalyani University; Prof. Dhananjay Bhattacharyya, Saha Institute of Nuclear Physics; Prof. Subir Sarkar, Jadavpur University; Prof. Partha P. Bhattacharya, Mody University, Sikar; Prof. Alok K. Rastogi, Institute for Excellence in Higher Education, Bhopal; Dr. Srabani Mukhopadhyay, BIT Mesra, Kolkata Extension Centre; Prof. Sarmistha Neogy, Jadavpur University; Prof. Siddhartha Bhattacharya, RCC Institute of Information Technology, Calcutta; Dr. Nitin Auluck, IIT Ropar, Rupnagar; Dr. Surya P. Singh, IIT Delhi; Prof. Atul Sharma, Thapar University, Patiala; Prof. Marjit M. Singh, NERIST, Itanagar for their valuable time and efforts in organizing the conference

successfully. Finally, my special appreciation goes to Mr. Aninda Bose, Senior Editor, Springer India Pvt. Ltd., New Delhi for his advice.

We are grateful to the Institution of Electronics and Telecommunication Engineers for being the technical sponsors and Panipat Refinery and Petrochemicals, Indian Oil Corporation Ltd., Panipat, for partial financial support.

I am sure this volume will be indispensable for the researchers engaged in computing and communication technologies.

Bangalore, India
December 2016

Lalit M. Patnaik
INSA Senior Scientist and Adjunct Professor
Conference General Chair, 10th ICACCT 2016
Consciousness Studies Program
www.lmpatnaik.in

Contents

Part I Advanced Computing: Computational Intelligence

Suitability of CORDA Model for Area Coverage Problem	3
Deepanwita Das and Srabani Mukhopadhyaya	
A Hybrid of Fireworks and Harmony Search Algorithm for Multilevel Image Thresholding	11
Shivali, Lalit Maurya, Ekta Sharma, Prasant Mahapatra and Amit Doegar	
Performance Evaluation of New Text Mining Method Based on GA and K-Means Clustering Algorithm	23
Neha Garg and R.K. Gupta	
Modeling Stochastic Dynamic Facility Layout Using Hybrid Fireworks Algorithm and Chaotic Simulated Annealing: A Case of Indian Garment Industry	31
Akash Tayal and Surya Prakash Singh	
Transition-Aware Human Activity Recognition Using eXtreme Gradient Boosted Decision Trees	41
Kunal Gusain, Aditya Gupta and Bhavya Popli	
Software Defect Prediction: A Comparison Between Artificial Neural Network and Support Vector Machine	51
Ishani Arora and Anju Saha	
Random Selection of Crossover Operation with Mutation for Image Encryption—A New Approach	63
Jalesh Kumar and S. Nirmala	
User-Interactive Recommender System for Electronic Products Using Fuzzy Numbers	73
Shalini Sharma, C. Rama Krishna, Shano Solanki, Khushleen Kaur and Sharandeep Kaur	

Selection of Genes Mediating Human Leukemia, Using Boltzmann Machine	83
Sougata Sheet, Anupam Ghosh and Sudhindu Bikash Mandal	
Survey of Classification Approaches for Glaucoma Diagnosis from Retinal Images	91
Niharika Thakur and Mamta Juneja	
Discovering Optimal Patterns for Forensic Pattern Warehouse	101
Vishakha Agarwal, Akhilesh Tiwari, R.K. Gupta and Uday Pratap Singh	
Part II Advanced Computing: Distributed Computing	
Comparative Study of Scheduling Algorithms in Heterogeneous Distributed Computing Systems	111
Mamta Padole and Ankit Shah	
Part III Advanced Computing: Knowledge Representation	
Knowledge Reasoning for Decision Support (KRDS) in Healthcare Environment	125
Nawaf Alharbe, Lizong Zhang and Anthony S. Atkins	
Object Detection from Video Sequences Using Deep Learning: An Overview	137
Dweepna Garg and Ketan Kotecha	
A Framework for Improved Cooperative Learning Algorithms with Expertness (ICLAE)	149
Deepak A. Vidhate and Parag Kulkarni	
Part IV Advanced Computing: Data Encryption	
Bicubic Interpolation Based Audio Authentication (BIAA)	163
Uttam Kr. Mondal and Jyotsna Kumar Mandal	
Hierarchical Metadata-Based Secure Data Retrieval Technique for Healthcare Application	175
Sayantani Saha, Priyanka Saha and Sarmistha Neogy	
Intelligent Multiple Watermarking Schemes for the Authentication and Tamper Recovery of Information in Document Image	183
K.R. Chetan and S. Nirmala	
Part V Advanced Computing: Big Data	
Research of Access Optimization of Small Files on Basis of B + Tree on Hadoop	197
Yan Wang, YuQiang Li, YuWen Li, Yilong Shi and Weiwei Li	

Part VI Advanced Computing: Machine Translation

English to Bodo Phrase-Based Statistical Machine Translation 207
 Md. Saiful Islam and Bipul Syam Purkayastha

Part VII Advanced Computing: Case Study

Modelling Sustainable Procurement: A Case of Indian Manufacturing Firm 221
 Harpreet Kaur and Surya Prakash Singh

Part VIII Advanced Computing: Miscellaneous—Social Networks

Key Author Analysis in Research Professionals’ Collaboration Network Based on Collaborative Index 233
 Anand Bihari and Sudhakar Tripathi

Part IX Communication Technologies

Localization in Wireless Sensor Networks Using Invasive Weed Optimization Based on Fuzzy Logic System 245
 Gaurav Sharma, Ashok Kumar, Prabhleen Singh and Mohammad Jibran Hafeez

Genetic Algorithm-Based Heuristic for Solving Target Coverage Problem in Wireless Sensor Networks 257
 Manju, Deepti Singh, Satish Chand and Bijendra Kumar

Target Coverage Heuristics in Wireless Sensor Networks 265
 Manju, Deepti Singh, Satish Chand and Bijendra Kumar

Effect of Black Hole Attack on MANET Reliability in DSR Routing Protocol 275
 Moirangthem Marjit Singh and Jyotsna Kumar Mandal

Part X Microelectronics and Antenna Design

Noise Performance and Design Optimization of a Piezoresistive MEMS Accelerometer Used in a Strapdown Medical Diagnostic System 287
 Sonali Biswas and Anup Kumar Gogoi

Current Mode Universal Filter Realization Employing CCIII and OTA-A Minimal Realization 297
 Tajinder Singh Arora

On the Design of Hexagon-Slotted Circular Fractal Antenna for C Band Applications 307
 Harpreet Kaur and Jagtar Singh

**An Efficient Single-Layer Crossing Based 4-Bit Shift Register
Using QCA** 315
Trailokya Nath Sasamal, Ashutosh Kumar Singh and Umesh Ghanekar

Wave Digital Realization of Current Conveyor Family 327
Richa Barsainya, Tarun Kumar Rawat and Rachit Mahendra

Author Index. 335

About the Editors

Ramesh K. Choudhary, former Director, Asia Pacific Institute of Information Technology, Panipat, obtained Ph.D. from VMU, Salem, has co-authored ‘Testing of Fault Tolerance Techniques’ published by Lambert Academic Publishing, Germany. He was the Indian Coordinator, Featured Europe and South Asia MObility Network (FUSION), an ERUSMUS MUNDUS (EU) project to foster partnerships of emerging Asian countries with the EU countries reinforcing the existing collaborations developed through the EU funded projects. He had also significantly contributed to the EU-ASIA mutual recognition of studies in engineering, management, and informatics. He is Fellow of Institution of Engineers (India), IETE, and Members of IEEE, ACM, and Chinese Association for Artificial Intelligence.

Jyotsna Kumar Mandal, former Dean, Faculty of Engineering, Technology and Management, is Senior Professor, Department of Computer Science and Engineering, University of Kalyani, India. He has obtained Ph.D. (Engg.) from Jadavpur University. Professor Mandal has co-authored six books, viz., Algorithmic Design of Compression Schemes and Correction Techniques—A Practical Approach; Symmetric Encryption—Algorithm, Analysis and Applications: Low Cost-based Security; Steganographic Techniques and Application in Document Authentication—An Algorithmic Approach; Optimization-based Filtering of Random Valued Impulses—An Algorithmic Approach; and Artificial Neural Network Guided Secured Communication Techniques: A Practical Approach; all published by Lambert Academic Publishing, Germany. He has authored more than 350 papers on a wide range of topics in international journals and proceedings. His profile is included in the 31st edition of Marque’s World Who’s Who published in 2013. His areas of research include coding theory, data and network security, remote sensing and GIS-based applications, data compression, error correction, visual cryptography and steganography, distributed and shared memory parallel programming. He is Fellow of Institution of Electronics and Telecommunication Engineers, and Members of IEEE, ACM, and Computer Society of India.

Dhananjay Bhattacharyya, Head of Computer Sciences Division, Saha Institute of Nuclear Physics, Calcutta, India, obtained Ph.D. from Indian Institute of Science, Bangalore, and is a postdoctoral fellow from National Institutes of Health, Bethesda, Maryland, USA. Dr. Bhattacharyya's research interest is in understanding structure–function relationship of biological macromolecules, particularly nucleic acids. In this context, he utilizes available crystallographic data to carry out molecular dynamics simulation and ab initio quantum chemical calculations to understand structural stabilization of nucleic acid bases and recognition of nucleic acid by other ligands. In order to understand different structural features of nucleic acids, the CS division at Saha Institute of Nuclear Physics has developed few software tools under his guidance, such as NUPARM, BPFIND, PyrHB Find, etc. Using some of these tools, the CS division has classified structures of different non-canonical base pairs appearing in RNA crystal structures. Dr. Bhattacharyya has successfully guided several doctoral candidates on computational biology and bioinformatics.

Suresh Chandra Satapathy

Vikrant Bhateja

Siba K. Udgata

Prasant Kumar Pattnaik *Editors*

Proceedings of the
5th International
Conference on
Frontiers in Intelligent
Computing: Theory
and Applications

FICTA 2016, Volume 2

Advances in Intelligent Systems and Computing

Volume 516

Series editor

Janusz Kacprzyk, Polish Academy of Sciences, Warsaw, Poland
e-mail: kacprzyk@ibspan.waw.pl

About this Series

The series “Advances in Intelligent Systems and Computing” contains publications on theory, applications, and design methods of Intelligent Systems and Intelligent Computing. Virtually all disciplines such as engineering, natural sciences, computer and information science, ICT, economics, business, e-commerce, environment, healthcare, life science are covered. The list of topics spans all the areas of modern intelligent systems and computing.

The publications within “Advances in Intelligent Systems and Computing” are primarily textbooks and proceedings of important conferences, symposia and congresses. They cover significant recent developments in the field, both of a foundational and applicable character. An important characteristic feature of the series is the short publication time and world-wide distribution. This permits a rapid and broad dissemination of research results.

Advisory Board

Chairman

Nikhil R. Pal, Indian Statistical Institute, Kolkata, India
e-mail: nikhil@isical.ac.in

Members

Rafael Bello Perez, Universidad Central “Marta Abreu” de Las Villas, Santa Clara, Cuba
e-mail: rbellop@uclv.edu.cu

Emilio S. Corchado, University of Salamanca, Salamanca, Spain
e-mail: escorchado@usal.es

Hani Hagras, University of Essex, Colchester, UK
e-mail: hani@essex.ac.uk

László T. Kóczy, Széchenyi István University, Győr, Hungary
e-mail: koczy@sze.hu

Vladik Kreinovich, University of Texas at El Paso, El Paso, USA
e-mail: vladik@utep.edu

Chin-Teng Lin, National Chiao Tung University, Hsinchu, Taiwan
e-mail: ctlin@mail.nctu.edu.tw

Jie Lu, University of Technology, Sydney, Australia
e-mail: Jie.Lu@uts.edu.au

Patricia Melin, Tijuana Institute of Technology, Tijuana, Mexico
e-mail: epmelin@hafsamx.org

Nadia Nedjah, State University of Rio de Janeiro, Rio de Janeiro, Brazil
e-mail: nadia@eng.uerj.br

Ngoc Thanh Nguyen, Wroclaw University of Technology, Wroclaw, Poland
e-mail: Ngoc-Thanh.Nguyen@pwr.edu.pl

Jun Wang, The Chinese University of Hong Kong, Shatin, Hong Kong
e-mail: jwang@mae.cuhk.edu.hk

More information about this series at <http://www.springer.com/series/11156>

Suresh Chandra Satapathy
Vikrant Bhateja · Siba K. Udgata
Prasant Kumar Pattnaik
Editors

Proceedings of the 5th International Conference on Frontiers in Intelligent Computing: Theory and Applications

FICTA 2016, Volume 2

 Springer

Editors

Suresh Chandra Satapathy
Department of Computer Science
and Engineering
Anil Neerukonda Institute of Technology
and Sciences
Visakhapatnam, Andhra Pradesh
India

Vikrant Bhateja
Shri Ramswaroop Memorial Group
of Professional Colleges (SRMGPC)
Lucknow, Uttar Pradesh
India

Siba K. Udgata
SCIS
University of Hyderabad
Hyderabad
India

Prasant Kumar Pattnaik
School of Computer Engineering
KIIT University
Bhubaneswar, Odisha
India

ISSN 2194-5357

Advances in Intelligent Systems and Computing

ISBN 978-981-10-3155-7

DOI 10.1007/978-981-10-3156-4

ISSN 2194-5365 (electronic)

ISBN 978-981-10-3156-4 (eBook)

Library of Congress Control Number: 2016957505

© Springer Nature Singapore Pte Ltd. 2017

This work is subject to copyright. All rights are reserved by the Publisher, whether the whole or part of the material is concerned, specifically the rights of translation, reprinting, reuse of illustrations, recitation, broadcasting, reproduction on microfilms or in any other physical way, and transmission or information storage and retrieval, electronic adaptation, computer software, or by similar or dissimilar methodology now known or hereafter developed.

The use of general descriptive names, registered names, trademarks, service marks, etc. in this publication does not imply, even in the absence of a specific statement, that such names are exempt from the relevant protective laws and regulations and therefore free for general use.

The publisher, the authors and the editors are safe to assume that the advice and information in this book are believed to be true and accurate at the date of publication. Neither the publisher nor the authors or the editors give a warranty, express or implied, with respect to the material contained herein or for any errors or omissions that may have been made.

Printed on acid-free paper

This Springer imprint is published by Springer Nature

The registered company is Springer Nature Singapore Pte Ltd.

The registered company address is: 152 Beach Road, #22-06/08 Gateway East, Singapore 189721, Singapore

Preface

The volume is a collection of high-quality peer-reviewed research papers presented at the 5th International Conference on Frontiers in Intelligent Computing: Theory and Applications (FICTA 2016) held at School of Computer Engineering, KIIT University, Bhubaneswar, Odisha, India, during 16–17 September 2016.

The idea of this conference series was conceived by few eminent professors and researchers from premier institutions of India. The first three editions of this conference: FICTA 2012, 2013 and 2014 were organized by Bhubaneswar Engineering College (BEC), Bhubaneswar, Odisha, India. Owing to its popularity and wider visibility in the entire country as well as abroad; the fourth edition of FICTA 2015 has been organized by the prestigious NIT, Durgapur, West Bengal, India. All papers of past FICTA editions are published by Springer AISC Series. Presently, FICTA 2016 is the fifth edition of this conference series which brings researchers, scientists, engineers, and practitioners on to a single platform to exchange and share their theories, methodologies, new ideas, experiences and applications in all areas of intelligent computing theories and applications to various engineering disciplines such as computer science, electronics, electrical, mechanical, and biomedical engineering, etc.

FICTA 2016 had received a good number of submissions from the different areas relating to intelligent computing and its applications, and after a rigorous peer-review process with the help of our program committee members and external reviewers (from the country as well as abroad), good quality papers were selected for publications. The review process has been very crucial with minimum 2 reviews each and in many cases 3–5 reviews along with due checks on similarity and overlaps as well. The number of papers received under FICTA 2016 touched 500 mark including the main track and special sessions. The conference featured eight special sessions in various cutting edge technologies of specialized focus which were organized and chaired by eminent professors. The total number of papers received includes submissions from eight overseas countries. Out of this

pool of received papers, only 150 papers were given acceptance yielding an acceptance ratio of 0.4. These papers have been arranged in two separate volumes: Volume 1: 79 chapters and Volume 2: 71 chapters.

The conference featured many distinguished keynote addresses by eminent speakers like Dr. João Manuel and R.S. Tavares, Faculdade de Engenharia da Universidade do Porto, Porto, Portugal on Computational Image Analysis: Methods and Applications; Dr. Swagatam Das, ISI Kolkata on Swarm Intelligence; Dr. Rajib Mall, Information Technology IIT, Kharagpur; Dr. V. Ravi, Centre of Excellence in Analytics Institute for Development and Research in Banking Technology (IDRBT), (Established by RBI, India) Hyderabad; Dr. Gautam Sanyal, Professor, Department of CSE, NIT Durgapur on Image Processing and Intelligent Computing; and a plenary session on ‘How to write for and get published in scientific journals?’ by Mr. Aninda Bose, Senior Publishing Editor, Springer India.

We thank the General Chairs: Prof. Samaresh Mishra and Prof. Jnyana Ranjan Mohanty at KIIT University Bhubaneswar, India, for providing valuable guidance and inspiration to overcome various difficulties in the process of organizing this conference. We extend our heartfelt thanks to the honorary chairs of this conference: Dr. B.K. Panigrahi, IIT Delhi, and Dr. Swagatam Das, ISI Kolkata, for being with us from the very beginning to the end of this conference, and without their support, this conference could never have been successful. Our heartfelt thanks are due to Prof. P.N. Suganthan, NTU Singapore, for his valuable suggestions on enhancing editorial review process.

We would also like to thank School of Computer Engineering, KIIT University, Bhubaneswar, having coming forward to support us to organize the fifth edition of this conference series. We are amazed to note the enthusiasm of all faculty, staff and students of KIIT to organize the conference in a professional manner. Involvements of faculty coordinators and student volunteers are praiseworthy in every respect. We are confident that in future too we would like to organize many more international level conferences in this beautiful campus. We would also like to thank our sponsors for providing all the support and financial assistance.

We take this opportunity to thank authors of all submitted papers for their hard work, adherence to the deadlines and patience with the review process. The quality of a refereed volume depends mainly on the expertise and dedication of the reviewers. We are indebted to the program committee members and external reviewers who not only produced excellent reviews but also did these in short time frames.

We would also like to thank the participants of this conference, who have considered the conference above all hardships. Finally, we would like to thank all the volunteers who spent tireless efforts in meeting the deadlines and arranging every detail to make sure that the conference can run smoothly. Additionally, CSI Students Branch of ANITS and its team members have contributed a lot to this conference and deserve an appreciation for their contribution.

All efforts are worth and would please us all, if the readers of this proceedings and participants of this conference found the papers and conference inspiring and enjoyable. Our sincere thanks goes to all in press, print and electronic media for their excellent coverage of this conference.

We take this opportunity to thank all keynote speakers, track and special session chairs for their excellent support to make FICTA 2016 a grand success.

Visakhapatnam, India
Lucknow, India
Hyderabad, India
Bhubaneswar, India

Suresh Chandra Satapathy
Vikrant Bhateja
Siba K. Udgata
Prasant Kumar Pattnaik

Organization

Chief Patron

Achyuta Samanta, KISS and KIIT, Bhubaneswar, India

Patron

P.P. Mathur, KIIT University, Bhubaneswar, India

Advisory Committee

Sasmita Samanta, KIIT University, Bhubaneswar, India
Ganga Bishnu Mund, KIIT University, Bhubaneswar, India
Madhabananda Das, KIIT University, Bhubaneswar, India
Prasant Kumar Pattnaik, KIIT University, Bhubaneswar, India
Sudhanshu Sekhar Singh, KIIT University, Bhubaneswar, India

General Chair

Samaresh Mishra, KIIT University Bhubaneswar, India

General Co-chair

Jnyana Ranjan Mohanty, KIIT University, Bhubaneswar, India

Honorary Chairs

Dr. Swagatam Das, ISI Kolkota, India
Dr. B.K. Panigrahi, IIT Delhi, India

Convener

Chittaranjan Pradhan, KIIT University, Bhubaneswar, India

Organizing Chairs

Sachi Nandan Mohanty, KIIT University, Bhubaneswar, India
Sidharth Swarup Routaray, KIIT University, Bhubaneswar, India

Publication Chairs

Suresh Chandra Satapathy, ANITS, Visakhapatnam, India
Vikrant Bhateja, SRMGPC, Lucknow (U.P.), India

Steering Committee

Suresh Chandra Satapathy, ANITS, Visakhapatnam, India
Siba K. Udgata, UoH, Hyderabad, India
Manas Sanyal, University of Kalayani, India
Nilanjan Dey, TICT, Kolkota, India
B.N. Biswal, BEC, Bhubaneswar, India
Vikrant Bhateja, SRMGPC, Lucknow (U.P.), India

Editorial Board

Suresh Chandra Satapathy, ANITS, Visakhapatnam, India
Vikrant Bhateja, SRMGPC, Lucknow (U.P.), India
Siba K. Udgata, UoH, Hyderabad, India
Prasant Kumar Pattnaik, KIIT University, Bhubaneswar, India

Transport and Hospitality Chairs

Harish K. Pattnaik, KIIT University, Bhubaneswar, India
Manas K. Lenka, KIIT University, Bhubaneswar, India
Ramakant Parida, KIIT University, Bhubaneswar, India

Session Management Chairs

Manoj Kumar Mishra, KIIT University, Bhubaneswar, India
Suresh Ch. Moharana, KIIT University, Bhubaneswar, India
Sujoya Datta, KIIT University, Bhubaneswar, India

Registration Chairs

Himansu Das, KIIT University, Bhubaneswar, India
Manjusha Pandey, KIIT University, Bhubaneswar, India
Sharmistha Roy, KIIT University, Bhubaneswar, India
Sital Dash, KIIT University, Bhubaneswar, India

Publicity Chairs

J.K. Mandal, University of Kalyani, Kolkota, India
K. Srujan Raju, CMR Technical Campus, Hyderabad, India

Track Chairs

Machine Learning Applications: Steven L. Fernandez, SCEM, Mangalore, India
Image Processing and Pattern Recognition: V.N. Manjunath Aradhya, SJCE, Mysore, India
Big Data, Web Mining and IoT: Sireesha Rodda, Gitam University, Visakhapatnam, India
Signals, Communication and Microelectronics: A.K. Pandey, MIET, Meerut (U.P.), India
MANETs and Wireless Sensor Networks: Pritee Parwekar, ANITS, Visakhapatnam, India
Network Security and Cryptography: R.T. Goswami, BITS Mesra, Kolkota Campus, India
Data Engineering: M. Ramakrishna Murty, ANITS, Visakhapatnam, India
Data Mining: B. Janakiramaiah, DVR and Dr. HS MICCT, Kanchikacherla, India

Special Session Chairs

SS01: Wireless Sensor Networks: Architecture, Applications, Data Management and Security: Pritee Parwekar, ANITS, Visakhapatnam, India and Sireesha Rodda, Gitam University, Visakhapatnam, India
SS02: Advances in Document Image Analysis: V.N. Manjunath Aradhya, SJCE, Mysore, India
SS03: Computational Swarm Intelligence: Sujata Dash, North Orissa University, Baripada, India and Atta Ur Rehman, (BIIT) PMAS Arid Agricultural University, Rawalpindi, Punjab, Pakistan
SS04: Wide-Area-Wireless Communication Systems-Microwave, 3G, 4G and WiMAX: K. Meena (Jeyanthi), PSNACET, Dindigul, Tamil Nadu, India

SS05: Innovation in Engineering and Technology through Computational Intelligence Techniques: Jitendra Agrawal, RGPV, M.P., India and Shikha Agrawal, RGPV, M.P., India

SS06: Optical Character Recognition and Natural Language Processing: Nikisha B. Jariwala, Smt. Tanuben and Dr. Manubhai Trivedi CIS, Surat, Gujarat, India and Hardik A. Vyas, BMAIIT, Uka Tarsadia University, Bardoli, Gujarat, India

SS07: Recent Advancements in Information Security: Musheer Ahmad Jamia Millia Islamia, New Delhi, India

SS08: Software Engineering in Multidisciplinary Domains: Suma V., Dayananda Sagar College of Engineering, Bangalore, India

Technical Program Committee/International Reviewer Board

A. Govardhan, India
 Aarti Singh, India
 Almoataz Youssef Abdelaziz, Egypt
 Amira A. Ashour, Egypt
 Amulya Ratna Swain, India
 Ankur Singh Bist, India
 Athanasios V. Vasilakos, Athens
 Banani Saha, India
 Bhabani Shankar Prasad Mishra, India
 B. Tirumala Rao, India
 Carlos A. Coello, Mexico
 Charan S.G., India
 Chirag Arora, India
 Chilukuri K. Mohan, USA
 Chung Le, Vietnam
 Dac-Nhuong Le, Vietnam
 Delin Luo, China
 Hai Bin Duan, China
 Hai V. Pham, Vietnam
 Heitor Silvério Lopes, Brazil
 Igor Belykh, Russia
 J.V.R. Murthy, India
 K. Parsopoulos, Greece
 Kamble Vaibhav Venkatrao, India
 Kailash C. Patidar, South Africa
 Koushik Majumder, India
 Lalitha Bhaskari, India
 Jeng-Shyang Pan, Taiwan
 Juan Luis Fernández Martínez, California
 Le Hoang Son, Vietnam
 Leandro Dos Santos Coelho, Brazil

L. Perkin, USA
Lingfeng Wang, China
M.A. Abido, Saudi Arabia
Maurice Clerc, France
Meftah Boudjelal, Algeria
Monideepa Roy, India
Mukul Misra, India
Naeem Hanoon, Malaysia
Nikhil Bhargava, India
Oscar Castillo, Mexico
P.S. Avadhani, India
Rafael Stubs Parpinelli, Brazil
Ravi Subban, India
Roderich Gross, England
Saeid Nahavandi, Australia
Sankhadeep Chatterjee, India
Sanjay Sengupta, India
Santosh Kumar Swain, India
Saman Halgamuge, India
Sayan Chakraborty, India
Shabana Urooj, India
S.G. Ponnambalam, Malaysia
Srinivas Kota, Nebraska
Srinivas Sethi, India
Sumanth Yenduri, USA
Suberna Kumar, India
T.R. Dash, Cambodia
Vipin Tyagi, India
Vimal Mishra, India
Walid Barhoumi, Tunisia
X.Z. Gao, Finland
Ying Tan, China
Zong Woo Geem, USA
M. Ramakrishna Murthy, India
Tushar Mishra, India
And many more...

Contents

Information Retrieval for Gujarati Language Using Cosine Similarity Based Vector Space Model	1
Rajnish M. Rakholia and Jatinderkumar R. Saini	
BLDC Motor Drive with Power Factor Correction Using PWM Rectifier	11
P. Sarala, S.F. Kodad and B. Sarvesh	
Threshold Based Clustering Algorithm Analyzes Diabetic Mellitus	27
Preeti Mulay, Rahul Raghvendra Joshi, Aditya Kumar Anguria, Alisha Gonsalves, Dakshayaa Deepankar and Dipankar Ghosh	
Bio-Inspired Algorithms for Mobile Location Management—A New Paradigm	35
Swati Swayamsiddha, Smita Parija, Sudhansu Sekhar Singh and Prasanna Kumar Sahu	
TKAR: Efficient Mining of Top-k Association Rules on Real—Life Datasets	45
O. Gireesha and O. Obulesu	
Predicting Defect of Software System	55
Soumi Ghosh, Ajay Rana and Vineet Kansal	
Fusion of Medical Image Using STSVD	69
K.N. Narasimha Murthy and J. Kusuma	
Modified Cuckoo Search Algorithm for Fittest Relay Identification in Microgrid	81
O.V. Gnana Swathika, Santanab Mukhopadhyay, Yatharth Gupta, Arka Das and S. Hemamalini	

Optimization of Overcurrent Relays in Microgrid Using Interior Point Method and Active Set Method 89
O.V. Gnana Swathika, Arka Das, Yatharth Gupta, Santanab Mukhopadhyay and S. Hemamalini

Series Smart Wire—Managing Load and Congestion in Transmission Line 99
Abhishek, Divya Asija, Pallavi Choudekar and Yogasree Manganuri

Gene Ontology Based Function Prediction of Human Protein Using Protein Sequence and Neighborhood Property of PPI Network. 109
Sovan Saha, Piyali Chatterjee, Subhadip Basu and Mita Nasipuri

PLoc-Euk: An Ensemble Classifier for Prediction of Eukaryotic Protein Sub-cellular Localization 119
Rajkamal Mitra, Piyali Chatterjee, Subhadip Basu, Mahantapas Kundu and Mita Nasipuri

Drive-by-Download Malware Detection in Hosts by Analyzing System Resource Utilization Using One Class Support Vector Machines. 129
Prabaharan Poornachandran, S. Praveen, Aravind Ashok, Manu R. Krishnan and K.P. Soman

Privacy Preserving Data Mining: A Parametric Analysis 139
Darshana Patel and Radhika Kotecha

Low Power 14T Hybrid Full Adder Cell 151
Chauhan Sugandha and Sharma Tripti

Improved Dynamic Time Warping Based Approach for Activity Recognition 161
Vikas Tripathi, Sharat Agarwal, Ankush Mittal and Durgaprasad Gangodkar

STRIDE Based Analysis of the Chrome Browser Extensions API 169
P.K. Akshay Dev and K.P. Jevitha

Some Properties of Rough Sets on Fuzzy Approximation Spaces and Applications. 179
B.K. Tripathy and Suvendu Kumar Parida

Design and Optimization of Fractal Antenna for UWB Application 189
Arati Behera, Sarmistha Satrusallya and Mihir Narayan Mohanty

Multi-objective IT Professionals’ Utilization Problems Using Fuzzy Goal Programming 199
R.K. Jana, M.K. Sanyal and Saikat Chakrabarti

Convex Hyperspectral Unmixing Algorithm Using Parameterized Non-convex Penalty Function 209
 K. HariKumar and K.P. Soman

Novel Techniques for Detection of Anomalies in Brain MR Images. 219
 K. Bhima and A. Jagan

Cryptanalysis of Secure Routing Among Authenticated Nodes in MANETs. 227
 Rajeev Ranjan

EEG Based Oscitancy Classification System for Accidental Prevention. 235
 Jay Sarraf, Satarupa Chakrabarty and Prasant Kumar Pattnaik

Robust Flare Phase Auto Landing of Aircrafts, Based on Modified ASBO. 245
 G. Parimala Gandhi, Nagaraj Ramrao and Manoj Kumar Singh

RSentiment: A Tool to Extract Meaningful Insights from Textual Reviews. 259
 Subhasree Bose, Urmi Saha, Debanjana Kar, Saptarsi Goswami, Amlan Kusum Nayak and Satyajit Chakrabarti

A Purely Localized Random Key Sequencing Using Accelerated Hashing in Wireless Ad-Hoc Networks. 269
 Amit Kumar, Vijay K. Katiyar and Kamal Kumar

GOASREP: Goal Oriented Approach for Software Requirements Elicitation and Prioritization Using Analytic Hierarchy Process. 281
 Nikita Garg, Mohd. Sadiq and Pankaj Agarwal

Confidentiality and Storage of Data in Cloud Environment 289
 Prerna Mohit and G.P. Biswas

A Method for the Selection of Agile Methods Using AHP. 297
 Bushra Sayed, Zeba Shamsi and Mohd. Sadiq

Load Balancing with Job Switching in Cloud Computing Network. 305
 Ranjan Kumar Mondal, Subhranshu Roy, Palash Samanta, Payel Ray, Enakshmi Nandi, Biswajit Biswas, Manas Kumar Sanyal and Debabrata Sarddar

An Efficient Detection and Mitigation of Selfish and Black Hole Attack in Cognitive Mobile Ad-hoc Network 313
 Deepa and Jayashree Agarkhed

An Innovative Method for Load Balanced Clustering Problem for Wireless Sensor Network in Mobile Cloud Computing	325
Debabrata Sarddar, Enakshmi Nandi, Anil Kumar Sharma, Biswajit Biswas and Manas Sanyal	
Dengue Fever Classification Using Gene Expression Data: A PSO Based Artificial Neural Network Approach	331
Sankhadeep Chatterjee, Sirshendu Hore, Nilanjan Dey, Sayan Chakraborty and Amira S. Ashour	
Modified Non Linear Diffusion Approach for Multiplicative Noise	343
Vikrant Bhateja, Aditi Sharma, Abhishek Tripathi and Suresh Chandra Satapathy	
L-Slotted Microstrip Fed Monopole Antenna for Triple Band WLAN and WiMAX Applications	351
Chandan, Toolika Srivastava and B.S. Rai	
Performance Analysis of Fully Depleted SOI Tapered Body Reduced Source (FD-SOI TBRS) MOSFET for Low Power Digital Applications	361
Vimal Kumar Mishra and R.K. Chauhan	
A Study and Analysis of Different Brain Tumor Segmentation Techniques	369
K. Mahantesh, B.V. Sandesh Kumar and V.N. Manjunath Aradhya	
A Novel Representation for Classification of User Sentiments	379
Steven Lawrence Fernandes, S.N. Bharath Bhushan, Vinlal Vinod and M.J. Adarsh	
A 3D Approach for Palm Leaf Character Recognition Using Histogram Computation and Distance Profile Features	387
Panyam Narahari Sastry, T.R. Vijaya Lakshmi, N.V. Koteswara Rao and Krishnan RamaKrishnan	
Feature Optimization to Recognize Telugu Handwritten Characters by Implementing DE and PSO Techniques	397
T.R. Vijaya Lakshmi, Panyam Narahari Sastry and T.V. Rajinikanth	
Writer Specific Parameters for Online Signature Verification	407
K.S. Manjunatha, S. Manjunath and D.S. Guru	
Word-Level Script Identification from Scene Images	417
O.K. Fasil, S. Manjunath and V.N. Manjunath Aradhya	
Recognizing Human Faces with Tilt	427
H.S. Jagadeesh, K. Suresh Babu and K.B. Raja	

Cloud Computing Technology as an Auto Filtration System for Cost Reduction While Roaming 437
 S. Biswas, A. Mukherjee, M. Roy Chowdhury and A.B. Bhattacharya

Design of Visual Cryptography Scheme Using C(m, w) Combinations 447
 Anindya Kr. Biswas, S. Mukhopadhyay and G.P. Biswas

A Secured Digital Signature Using Conjugacy and DLP on Non-commutative Group over Finite Field 457
 L. Narendra Mohan and G.S.G.N. Anjaneyulu

A Novel Edge Based Chaotic Steganography Method Using Neural Network 467
 Shahzad Alam, Tanvir Ahmad and M.N. Doja

A Latest Comprehensive Study on Structured Threat Information Expression (STIX) and Trusted Automated Exchange of Indicator Information (TAXII) 477
 M. Apoorva, Rajesh Eswarawaka and P. Vijay Bhaskar Reddy

Preventive Maintenance Approach for Storage and Retrieval of Sensitive Data 483
 V. Madhusudhan and V. Suma

Join Operations to Enhance Performance in Hadoop MapReduce Environment 491
 Pavan Kumar Pagadala, M. Vikram, Rajesh Eswarawaka and P. Srinivasa Reddy

Adaptive Spatio-Temporal Filtering with Motion Estimation for Mixed Noise Removal and Contrast Enhancement in Video Sequence 501
 S. Madhura and K. Suresh

Social and Temporal-Aware Personalized Recommendation for Best Spreaders on Information Sharing 509
 Ananthi Sheshasaayee and Hariharan Jayamangala

A Combined System for Regionalization in Spatial Data Mining Based on Fuzzy C-Means Algorithm with Gravitational Search Algorithm 517
 Ananthi Sheshasaayee and D. Sridevi

Design and Functional Verification of Axi2OCP Bridge for Highly Optimized Bus Utilization and Closure Using Functional Coverage 525
 N. Shalini and K.P. Shashikala

Person Recognition Using Surf Features and Vola-Jones Algorithm	537
S. Shwetha, Sunanda Dixit and B.I. Khondanpur	
2D Shape Representation and Analysis Using Edge Histogram and Shape Feature	545
G.N. Manjula and Muzameel Ahmed	
Automatic Classification of Lung Nodules into Benign or Malignant Using SVM Classifier	551
B. Sasidhar, G. Geetha, B.I. Khondanpur and D.R. Ramesh Babu	
Automatic Detection of Diabetic Retinopathy Using Two Phase Tophat Transformations—A Novel Approach	561
A.S. Akshaya, Sunanda Dixit and Ngangom Priyobata Singh	
Evaluation of Heart Rate Using Reflectance of an Image	571
Neha Deshmukh, Sunanda Dixit and B.I. Khondanpur	
Analysis of Logs by Using Logstash	579
Sushma Sanjappa and Muzammel Ahmed	
Estimation of Degree of Connectivity to Predict Quality of Software Design	587
S.D. Thilothame, M. Mashetty Chitralkha, U.S. Poornima and V. Suma	
Multipath Load Balancing and Secure Adaptive Routing Protocol for Service Oriented WSNs	595
C.P. Anandkumar, A.M. Prasad and V. Suma	
Visual Based Information Retrieval Using Voronoi Tree	603
Megha Biradar and Muzameel Ahmed	
Gradient Magnitude Based Watershed Segmentation for Brain Tumor Segmentation and Classification	611
Ngangom Priyobata Singh, Sunanda Dixit, A.S. Akshaya and B. I. Khondanpur	
Information Retrieval Through the Web and Semantic Knowledge-Driven Automatic Question Answering System	621
Ananthi Sheshasaayee and S. Jayalakshmi	
Level Set Based Liver Segmentation and Classification by SVM	633
Mallikarjun Kesaratti, Sunanda Dixit and B.I. Khondanpur	
An Exploratory Study of RDF: A Data Model for Cloud Computing	641
A. Clara Kanmani, T. Chockalingam and N. Guruprasad	

Domain Independent Approach for Aspect Oriented Sentiment Analysis for Product Reviews	651
Nilesh Shelke, Shrinivas Deshpande and Vilas Thakare	
Approach for Emotion Extraction from Text	661
Nilesh Shelke, Shrinivas Deshpande and Vilas Thakare	
Performance of Multiple String Matching Algorithms in Text Mining	671
Ananthi Sheshasaayee and G. Thailambal	
Author Index	683

About the Editors

Dr. Suresh Chandra Satapathy is currently working as a professor and head, Department of Computer Science and Engineering, Anil Neerukonda Institute of Technology and Sciences (ANITS), Visakhapatnam, Andhra Pradesh, India. He obtained his Ph.D. in Computer Science Engineering from JNTUH, Hyderabad, and master's degree in Computer Science and Engineering from National Institute of Technology (NIT), Rourkela, Odisha. He has more than 27 years of teaching and research experience. His research interest includes machine learning, data mining, swarm intelligence studies and their applications to engineering. He has more than 98 publications to his credit in various reputed international journals and conference proceedings. He has edited many volumes from Springer AISC, LNEE, SIST and LNCS in past, and he is also the editorial board member in few international journals. He is a senior member of IEEE and life member of Computer Society of India. Currently, he is the national chairman of Division-V (Education and Research) of Computer Society of India.

Prof. Vikrant Bhateja is an associate professor, Department of Electronics and Communication Engineering, Shri Ramswaroop Memorial Group of Professional Colleges (SRMGPC), Lucknow, and also the head (Academics and Quality Control) in the same college. His areas of research include digital image and video processing, computer vision, medical imaging, machine learning, pattern analysis and recognition. He has published 100 quality publications in various international journals and conference proceedings. Professor Vikrant has been on TPC and chaired various sessions from the above domain in international conferences of IEEE and Springer. He has been the track chair and served in the core-technical/editorial teams for international conferences: FICTA 2014, CSI 2014, INDIA 2015, ICICT 2015 and ICTIS 2015 under Springer-ASIC Series and INDIACom 2015 and ICACCI 2015 under IEEE. He is an associate editor in International Journal of Synthetic Emotions (IJSE) and International Journal of Ambient Computing and Intelligence (IJACI) under IGI Global. He is also serving in the editorial board of International Journal of Image Mining (IJIM) and International Journal of Convergence Computing (IJConvC) under Inderscience

Publishers. He has been the editor of three published volumes with Springer and another two are in press.

Dr. Siba K. Udgata is a professor of School of Computer and Information Sciences, University of Hyderabad, India. He is presently heading Centre for Modelling, Simulation and Design (CMSD), a high-performance computing facility at University of Hyderabad. He has got his Master's followed by Ph.D. in Computer Science (mobile computing and wireless communication). His main research interests are wireless communication, mobile computing, wireless sensor networks and intelligent algorithms. He was a United Nations Fellow and worked in the United Nations University/International Institute for Software Technology (UNU/IIST), Macau, as research fellow in the year 2001. Dr. Udgata is working as a principal investigator in many Government of India funded research projects mainly for the development of wireless sensor network applications and application of swarm intelligence techniques. He has published extensively in refereed international journals and conferences in India as well as abroad. He has edited many volumes in Springer LNCS/LNAI and Springer AISC Proceedings.

Dr. Prasant Kumar Pattnaik Ph.D. (Computer Science), Fellow IETE, Senior Member IEEE is a professor at the School of Computer Engineering, KIIT University, Bhubaneswar. He has more than a decade of teaching and research experience. Dr. Pattnaik has published numbers of research papers in peer-reviewed International Journals and conferences. His areas of specialization are mobile computing, cloud computing, brain computer interface and privacy preservation.

Rituparna Chaki
Khalid Saeed
Agostino Cortesi
Nabendu Chaki *Editors*

Advanced Computing and Systems for Security

Volume Four

Advances in Intelligent Systems and Computing

Volume 568

Series editor

Janusz Kacprzyk, Polish Academy of Sciences, Warsaw, Poland
e-mail: kacprzyk@ibspan.waw.pl

About this Series

The series “Advances in Intelligent Systems and Computing” contains publications on theory, applications, and design methods of Intelligent Systems and Intelligent Computing. Virtually all disciplines such as engineering, natural sciences, computer and information science, ICT, economics, business, e-commerce, environment, healthcare, life science are covered. The list of topics spans all the areas of modern intelligent systems and computing.

The publications within “Advances in Intelligent Systems and Computing” are primarily textbooks and proceedings of important conferences, symposia and congresses. They cover significant recent developments in the field, both of a foundational and applicable character. An important characteristic feature of the series is the short publication time and world-wide distribution. This permits a rapid and broad dissemination of research results.

Advisory Board

Chairman

Nikhil R. Pal, Indian Statistical Institute, Kolkata, India
e-mail: nikhil@isical.ac.in

Members

Rafael Bello Perez, Universidad Central “Marta Abreu” de Las Villas, Santa Clara, Cuba
e-mail: rbellop@uclv.edu.cu

Emilio S. Corchado, University of Salamanca, Salamanca, Spain
e-mail: escorchado@usal.es

Hani Hagra, University of Essex, Colchester, UK
e-mail: hani@essex.ac.uk

László T. Kóczy, Széchenyi István University, Győr, Hungary
e-mail: koczy@sze.hu

Vladik Kreinovich, University of Texas at El Paso, El Paso, USA
e-mail: vladik@utep.edu

Chin-Teng Lin, National Chiao Tung University, Hsinchu, Taiwan
e-mail: ctlin@mail.nctu.edu.tw

Jie Lu, University of Technology, Sydney, Australia
e-mail: Jie.Lu@uts.edu.au

Patricia Melin, Tijuana Institute of Technology, Tijuana, Mexico
e-mail: epmelin@hafsamx.org

Nadia Nedjah, State University of Rio de Janeiro, Rio de Janeiro, Brazil
e-mail: nadia@eng.uerj.br

Ngoc Thanh Nguyen, Wroclaw University of Technology, Wroclaw, Poland
e-mail: Ngoc-Thanh.Nguyen@pwr.edu.pl

Jun Wang, The Chinese University of Hong Kong, Shatin, Hong Kong
e-mail: jwang@mae.cuhk.edu.hk

More information about this series at <http://www.springer.com/series/11156>

Rituparna Chaki · Khalid Saeed · Agostino Cortesi
Nabendu Chaki
Editors

Advanced Computing and Systems for Security

Volume Four

 Springer

Editors

Rituparna Chaki
A.K. Choudhury School of Information
Technology
University of Calcutta
Kolkata, West Bengal
India

Khalid Saeed
Faculty of Computer Science
Bialystok University of Technology
Bialystok
Poland

Agostino Cortesi
DAIS—Università Ca' Foscari
Mestre, Venice
Italy

Nabendu Chaki
Department of Computer Science and
Engineering
University of Calcutta
Kolkata, West Bengal
India

ISSN 2194-5357 ISSN 2194-5365 (electronic)
Advances in Intelligent Systems and Computing
ISBN 978-981-10-3390-2 ISBN 978-981-10-3391-9 (eBook)
DOI 10.1007/978-981-10-3391-9

Library of Congress Control Number: 2016960766

© Springer Nature Singapore Pte Ltd. 2017

This work is subject to copyright. All rights are reserved by the Publisher, whether the whole or part of the material is concerned, specifically the rights of translation, reprinting, reuse of illustrations, recitation, broadcasting, reproduction on microfilms or in any other physical way, and transmission or information storage and retrieval, electronic adaptation, computer software, or by similar or dissimilar methodology now known or hereafter developed.

The use of general descriptive names, registered names, trademarks, service marks, etc. in this publication does not imply, even in the absence of a specific statement, that such names are exempt from the relevant protective laws and regulations and therefore free for general use.

The publisher, the authors and the editors are safe to assume that the advice and information in this book are believed to be true and accurate at the date of publication. Neither the publisher nor the authors or the editors give a warranty, express or implied, with respect to the material contained herein or for any errors or omissions that may have been made.

Printed on acid-free paper

This Springer imprint is published by Springer Nature
The registered company is Springer Nature Singapore Pte Ltd.
The registered company address is: 152 Beach Road, #21-01/04 Gateway East, Singapore 189721, Singapore

Preface

The Third International Doctoral Symposium on Applied Computation and Security Systems (ACSS 2016) took place during August 12–14, 2016 in Kolkata, India organized by University of Calcutta in collaboration with NIT, Patna. The Ca Foscari University of Venice, Italy and Bialystok University of Technology, Poland were the international collaborators for ACSS 2016.

As the symposium turned to its third consecutive year, it has been interesting to note the kind of interests it has created among the aspiring doctoral scholars and the academic fraternity at large. The uniqueness of being a symposium created specifically for Ph.D. scholars and their doctoral research has already established ACSS as an inimitable event in this part of the globe. The expertise of the eminent members of the program committee helped in pointing out the pros and cons of the research works being discussed during the symposium. Even during presentation of each paper, the respective Session Chair(s) had responded to their responsibilities of penning down a feedback for more improvements of the paper. The final version of the papers thus goes through a second level of modification as per the session chair's comments, before being included in this post-conference book.

Team ACSS is always on the look-out for latest research topics, and in a bid to allow such works, we always include them to our previous interest areas. ACSS 2016 had Android Security as the chosen new interest area, thus inviting researchers working in the domains of data analytics, cloud and service management, security systems, high performance computing, algorithms, image processing, pattern recognition.

The sincere effort of the program committee members, coupled with indexing initiatives from Springer, has drawn a large number of high-quality submissions from scholars all over India and abroad. A thorough double-blind review process has been carried out by the PC members and by external reviewers. While reviewing the papers, reviewers mainly looked at the novelty of the contributions, at the technical content, at the organization and at the clarity of presentation. The entire process of paper submission, review and acceptance process was done electronically. Due to the sincere efforts of the Program Committee and the Organizing Committee members, the symposium resulted in a suite of strong

technical paper presentations followed by effective discussions and suggestions for improvement for each researcher.

The Technical Program Committee for the symposium selected only 21 papers for publication out of 64 submissions after peer review. Later 5 more papers were chosen for presenting in the symposium after the authors submitted enhanced versions and those were reviewed again in a 2-tier pre-symposium review process.

We would like to take this opportunity to thank all the members of the Program Committee and the external reviewers for their excellent and time-bound review works. We thank all the sponsors who have come forward towards organization of this symposium. These include Tata Consultancy Services (TCS), Springer Nature, ACM India, M/s Neitec, Poland, and M/s Fujitsu, Inc., India. We appreciate the initiative and support from Mr. Aninda Bose and his colleagues in Springer Nature for their strong support towards publishing this post-symposium book in the series “Advances in Intelligent Systems and Computing”. Last but not least, we thank all the authors without whom the symposium would have not reached this standard.

On behalf of the editorial team of ACSS 2016, we sincerely hope that ACSS 2016 and the works discussed in the symposium will be beneficial to all its readers and motivate them towards even better works.

Kolkata, India
Białystok, Poland
Mestre, Venice, Italy
Kolkata, India

Rituparna Chaki
Khalid Saeed
Agostino Cortesi
Nabendu Chaki

Contents

Part I Cloud and Service Management

A Review on Energy Efficient Resource Management Strategies for Cloud	3
Srimoyee Bhattacharjee, Sunirmal Khatua and Sarbani Roy	
Modeling and Analysis of Enterprise Cloud Bus Using a Petri Net Based Approach	17
Gitosree Khan, Sabnam Sengupta and Anirban Sarkar	
Service Provisioning in Cloud: A Systematic Survey	37
Adrija Bhattacharya and Sankhayan Choudhury	

Part II High Performance Computing

Flexible Neural Trees—Parallel Learning on HPC	67
Jiří Hanzelka and Jiří Dvorský	
Software Energy Estimation to Improve Power Efficiency of Embedded System	79
Nachiketa Chatterjee, Saakallya Biswas and Partha Pratim Das	

Part III Image Processing

Ternary Quantum Circuit for Color Image Representation	95
Sanjay Chakraborty, Sudhindu Bikash Mandal, Soharab Hossain Shaikh and Lopamudra Dey	
A Graph-Theoretic Approach for Visualization of Data Set Feature Association	109
Amit Kumar Das, Saptarsi Goswami, Basabi Chakraborty and Amlan Chakrabarti	

A Novel Approach for Human Silhouette Extraction from Video Data	125
Amlan Raychaudhuri, Satyabrata Maity, Amlan Chakrabarti and Debotosh Bhattacharjee	
Part IV Pattern Recognition	
Statistical Textural Features for Text-Line Level Handwritten Indic Script Identification	139
Pawan Kumar Singh, Ram Sarkar and Mita Nasipuri	
An Approach to Stroke-Based Online Handwritten Bangla Character Recognition	153
Shibaprasad Sen, Ram Sarkar and Kaushik Roy	
Functional Group Prediction of Un-annotated Protein by Exploiting Its Neighborhood Analysis in Saccharomyces Cerevisiae Protein Interaction Network	165
Sovan Saha, Piyali Chatterjee, Subhadip Basu and Mita Nasipuri	
Author Index	179

About the Editors



Rituparna Chaki is Professor of Information Technology in the University of Calcutta, India. She received her Ph.D. Degree from Jadavpur University in India in 2003. Before this she completed B.Tech. and M.Tech. in Computer Science and Engineering from University of Calcutta in 1995 and 1997, respectively. She has served as a System Executive in the Ministry of Steel, Government of India for 9 years, before joining the academics in 2005 as a Reader of Computer Science and Engineering in the West Bengal University of Technology, India. She has been with the University of Calcutta since 2013.

Her areas of research include optical networks, sensor networks, mobile ad hoc networks, Internet of Things, data mining, etc. She has nearly 100 publications to her credit. Dr. Chaki has also served in the program committees of different international conferences. She has been a regular Visiting Professor in the AGH University of Science and Technology, Poland for last few years. Rituparna has co-authored couple of books published by CRC Press, USA.



Khalid Saeed is Full Professor in the Faculty of Computer Science, Bialystok University of Technology, Bialystok, Poland. He received the B.Sc. degree in Electrical and Electronics Engineering in 1976 from Baghdad University in 1976, the M.Sc. and Ph.D. degrees from Wroclaw University of Technology, in Poland in 1978 and 1981, respectively. He received his D.Sc. degree (Habilitation) in Computer Science from Polish Academy of Sciences in Warsaw in 2007. He was a visiting professor of Computer Science with Bialystok University of Technology, where he is now working as a full professor. He was with AGH University of Science and Technology during 2008–2014. He is also working as Professor with the Faculty of Mathematics and Information Sciences in Warsaw University of Technology. His areas of interest include biometrics, image analysis and processing and computer information Systems. He has published more than 220 publications, edited 28 books, journals and conference proceedings, 10 text and reference books. He has supervised more than 130 M.Sc. and 16 Ph.D. theses. He gave more than 40 invited lectures and keynotes in different conferences and universities in Europe, China, India, South Korea and Japan on biometrics, image analysis and processing. He has received more than 20 academic awards. Khalid Saeed is a member of more than 20 editorial boards of international journals and conferences. He is an IEEE Senior Member and has been selected as IEEE Distinguished Speaker for 2011–2016. Khalid Saeed is the Editor-in-Chief of International Journal of Biometrics with Inderscience Publishers.



Agostino Cortesi, Ph.D. is Full Professor of Computer Science at Ca' Foscari University, Venice, Italy. He served as Dean of the Computer Science studies, as Department Chair, and as Vice-Rector for quality assessment and institutional affairs.

His main research interests concern programming languages theory, software engineering, and static analysis techniques, with particular emphasis on security applications. He published more than 110 papers in high-level international journals and proceedings of international conferences. His h-index is 16 according to Scopus, and 24 according to Google Scholar. Agostino served several

times as member (or chair) of program committees of international conferences (e.g., SAS, VMCAI, CSF, CISIM, ACM SAC) and he's in the editorial boards of the journals "Computer Languages, Systems and Structures" and "Journal of Universal Computer Science". Currently, he holds the chairs of "Software Engineering", "Program Analysis and Verification", "Computer Networks and Information Systems" and "Data Programming".



Nabendu Chaki is Professor in the Department of Computer Science and Engineering, University of Calcutta, Kolkata, India. Dr. Chaki did his first graduation in Physics from the legendary Presidency College in Kolkata and then in Computer Science and Engineering from the University of Calcutta. He completed Ph.D. in 2000 from Jadavpur University, India. He shares six international patents including four U.S. patents with his students. Professor Chaki has been quite active in developing international standards for software engineering and cloud computing as a member of Global Directory (GD) member for ISO-IEC. Besides editing more than 25 book volumes, Nabendu has authored six text and research books and has more than 150 Scopus Indexed research papers in journals and international conferences. His areas of research interests include distributed systems, image processing and software engineering. Dr. Chaki has served as a Research Faculty in the Ph.D. program in Software Engineering in U.S. Naval Postgraduate School, Monterey, CA. He is a visiting faculty member for many universities in India and abroad. Besides being in the editorial board for several international journals, he has also served in the committees of over 50 international conferences. Professor Chaki is the founder Chair of ACM Professional Chapter in Kolkata.

Souvenir

INTERNATIONAL CONFERENCE ON COMPUTATIONAL INTELLIGENCE AND DATA ANALYTICS

ICCIDA-2018

26-27 October 2018

@ GIFT, Bhubaneswar, India

Organized by:



Department of Computer Science & Engineering
Gandhi Institute for Engineering
Bhubaneswar

In Association with



Springer

NHGSSC: New Hybrid Gene Selection-Sample Classification Method in Microarray Data

Chandra Das, Sayani Bag, Shilpi Bose, Kuntal Ghosh, Samiran Chattopadhyay
Department of CSE, NSEC, Kolkata, West Bengal, India
E-mail: daschandra08@gmail.com

Center for Soft Computing Research, ISI, Kolkata, West Bengal, India E-mail:
bagsayani09@gmail.com

Department of CSE, NSEC, Kolkata, West Bengal, India
E-mail: bosc.shilpi08@gmail.com

MIU, ISI, Kolkata, West Bengal, India
E-mail: kuntal.isical@gmail.com

Department of IT, JU, Kolkata, West Bengal, India
E-mail: samirancju@gmail.com

Abstract: After invention of DNA microarray technology researchers have started to believe it as an effective tool for diagnosis and classification of cancer. The gene expression dataset generated by DNA microarray technology contains expression profiles of huge quantities of genes for samples of very small in numbers. Among these genes, a very small number of genes are informative that means these genes have appropriate discriminating information for cancer sample identification and classification. These genes are considered as key biomarkers. Reliable set of biomarkers finding is an essential task of microarray gene expression data analysis for cancer sample identification and it has great impact on different biomedical fields. In this regard, a new hybrid gene selection-sample classification model (NHGSSC) is proposed here for selection of relevant genes and classification of cancer samples. The proposed hybrid model is a combination of two methods: (1) gene selection (2) sample classification. For gene selection, a new hybrid single filter and α -depth limited best first search based single wrapper method (SF α -BFSSW) is proposed for selection of most relevant subsets. From these subsets highly informative genes are selected by counting frequency of occurrence (FO) of every gene. Then SF α -BFSSW method based ensemble classifier (SF α -BFSSWEC) is built by combining the classifiers created for the selected gene subsets. Prediction accuracy of the proposed model is tested over different microarray data sets by comparing the results with different existing well known algorithms or models. Results demonstrate the superiority of NHGSSC to other existing models.

Keywords: DNA Microarray Technology, Gene expression data, Feature selection, Filter methods, Wrapper methods, Best First Search, Classification

An Ensemble Filtering Approach based Supervised Gene Clustering Algorithm to Identify Informative Genes to Improve Sample Classification Accuracy in Microarray Gene Expression Data

Shilpi Bose, Chandra Das, Matangini Chattopadhyay, Kuntal Ghosh, Samiran Chattopadhyay
Department of Computer Science & Engineering, Netaji Subhash Engineering College,
Garia, Kolkata-700152, West Bengal, India

E-mail: bose.shilpi08@gmail.com

Department of Computer Science & Engineering, Netaji Subhash Engineering College,
Garia, Kolkata-700152, West Bengal, India

E-mail: daschandra08@gmail.com

School of Education Technology, Jadavpur University, Kolkata, India

E-mail: matanginic@gmail.com

Machine Intelligence Unit, Indian Statistical Institute, Kolkata-700108, West Bengal, India

E-mail: kuntal.isical@gmail.com

Department of Information Technology, Jadavpur University, Kolkata, West Bengal, India

E-mail: samiranc@gmail.com

Abstract: Sample classification is one of the important downstream analysis based application of microarray gene expression data. Using DNA microarray technology it is possible to measure expression level of several thousand of genes for a few numbers of samples. The outcome of microarray technology, gene expression data matrix contains a huge number of genes compared to a limited number of samples and this is a most important problem for sample classification. Most classification algorithms suffer from such a high-dimensional input space. Also a small number of genes contain relevant information for sample classification. In, this regard, a new multi filtering ensemble approach based supervised gene clustering algorithm is proposed here. The proposed method works in two phases. In, the first phase most relevant genes are selected using multi filtering ensemble approach. In the second phase the selected relevant genes are clustered using sample class information to find groups of correlated genes closely associated with the samples categories. Then a number of most significant cluster representatives are selected as features for sample classification. The performance of the proposed algorithm is compared with existing supervised and unsupervised gene clustering algorithms as well as with popular filter based gene selection methods with respect to classification accuracy of k-nearest neighbor, Support vector machine and Naive Bayes classifiers on different microarray gene expression datasets. It has been found that the proposed method significantly outperforms in all cases.

Keywords: DNA Microarray Technology, Gene expression data, Feature selection, Filter methods, Attribute Clustering, Classification

See discussions, stats, and author profiles for this publication at: <https://www.researchgate.net/publication/318111508>

A new method for tutorial gap identification towards students modeling

Article · June 2017

DOI: 10.18280/mmep.040203

CITATION

1

READS

61

4 authors, including:



Atanu Das

Netaji Subhash Engineering College

39 PUBLICATIONS 62 CITATIONS

[SEE PROFILE](#)



Kaustuv Deb

Supreme Knowledge Foundation Group of Institutions

3 PUBLICATIONS 1 CITATION

[SEE PROFILE](#)



Rajib Bag

Supreme Knowledge Foundation Group of Institutions

22 PUBLICATIONS 32 CITATIONS

[SEE PROFILE](#)

Some of the authors of this publication are also working on these related projects:



Random Valued Impulse Noise Removal [View project](#)



Image Steganography [View project](#)



A new method for tutorial gap identification towards students modeling

Atanu Das^{1*}, Kaustuv Deb², Sonali Bajerjee², Rajib Bag²

¹ Netaji Subhash Engineering College, Kolkata, India

² Supreme Knowledge Foundation Group of Institutions, Mankundu, WB, India

Email: atanudas75@yahoo.co.in

ABSTRACT

Students modeling is an integral part of any form of education and this becomes more challenging with the advent of new tools of ICT especially Intelligent Tutoring Systems (ITS). Educators must have to take help of such tools to identify the curriculum gaps towards Outcome Based Education (OBE). One of the ways to reduce such gaps is to identify the personalized requirements of tutorials for learners after going through some topics divided into subtopics. This paper proposes a technique to identify the personalized tutorial gaps by analyzing the responses provided by students against MCQ type questions. The proposed method has been implemented within a web based environment. Prototype of the tool having integrated with the proposed method shows that the students can identify their tutorial requirement without the help of human tutor and hence discovering the student's understanding.

Keywords: ICT, OBE, Tutorial, Gap, Students Modeling.

1. INTRODUCTION

Educational world has been experiencing a paradigm shift from teacher centric education to outcome based education (OBE) [1-3] during last two decades. OBE has become accreditation requirements through out the world. OBE ensures cyclical processes which gurantes continuous improvement towards excellence. These cyclical processes involve implementing different mechanism for efficient student modeling. Students performances can not be enhanced unless such modeling is not assured at least at some desired level.

A student model is a representation of student understanding of a topic being taught. The model constructed by human tutors become more accurate with the experiences of the tutor. Such model construction is a difficult task and varies with teaching domains and teaching experiences. Often Intelligent Tutoring Systems (ITS) [5] have been used since the advent of using ICT tools for education for standardization of students modeling. Such models are used as personalized cognitive tool within the Intelligent Learning Environment (ILE).

There are several knowledge components within the representation of the students model. According to curriculum requirements, some components are required to be achieved by tutorials. But requirements of tutorials is not defined a priori in the curriculum most of the times and decided by human tutor as per his own experiences not according to learner's personalized model requirements.

This work advocates the use of automated ICT tools, if not ITS, for identifying personalized tutorials requirement gaps

after going through some set of topics (defined in the curriculum) or subtopics (subdivisions of topic). This identification could be achieved by analysing the responses of the students on a simple web based well designed MCQ test. There are two challenges in these endeavour. First is to design the MCQ test questions having one-to-many relationship maping with the subtopic level content. Second step is to analyse the responses corresponding to the questions to identify knowledge gap (also treated as curriculam gap) which could be fullfilled through the tutorial works specially. The last challenge has been focused in this work mostly.

2. RELATED WORKS

With the advent of OBE [1-3], education systems turning to exhibit more professionalism as expected in the developing economies. Outcome becomes the primary focus in these systems and accreditation requirement enforces to measure the same from a good number of parameters [1] among which one crucial is initiatives taken to bridge the curriculum gap besides competency assessments [6-9] of students after curriculum execution. One well known curriculum components are tutorial often ignored by human tutors because of shortage in time mostly. But even if time is strictly allocated for the same, inexperience teachers could not identify or wrongly identify the topics or subtopics on which tutorials classes need to be conducted at least for majority of students if not for all. Even though the teacher is having huge experience, he needs to analyse intelligently

each individual student before moving in to tutorial classes. To reduce the overload of human tutors, ICT based ITS [5] have been evolved which often took part in student modelling using knowledge based machine learning techniques.

It has been observed that construction of student model is a time-consuming task. Normally this is based on expert human inputs [14]. Structured interviews are conducted and the inputs are lucidly analysed for the same. Crucial instructional implications show that human engineering towards these models disregard the peculiarities between content and learning [11-12]. Learning Factor Analysis (LFA) [13] is another technique where automated search techniques are implemented for identification of knowledge components of the students' model. However, LFA conducts search processes in the closed periphery of human supplied factors. Nevertheless, these methods are somehow dependent on machines learning techniques [10] including complex mechanism.

To reduce these complexities, we propose a technique based on the analysis of student's responses on MCQ questions since the scope of this work is to model the student's tutorial requirements. The proposed scheme is somehow adhoc and expressive but includes procedural approaches.

3. PROPOSED METHOD

The curriculum gap identification required for OBE assessment has been considered here using identification of required tutorials as one of the crucial curriculum components. Educational delivery of the proposed system has been planned considering to the following processes.

1. Dividing the syllabus of a course into several topics as per lecture/delivery plan.
2. Delivery of contents on subtopics (unit of content delivery) of a topic.
3. Generation of MCQ questions set comprising questions having one-to-many relationship with the subtopics.
4. Conducting MCQ test for the students and collecting the question wise responses of the students.
5. Processing the student's responses to identify subtopics wise gap to be filled by tutorials based on some predefined threshold.

The scheme of the processing in the stage 5 is depicted below:

We consider a course with m modules. Now each module M_i , ($1 \leq i \leq m$) is divided into n number of topics. This method is going to operate on a particular topic $Topi_{ij}$, ($1 \leq j \leq n$). Each $Topi_{ij}$ is divided into p subtopics. A subtopic is denoted by $Sutopi_{ijk}$, ($1 \leq k \leq p$).

After completion of the delivery of contents on each subtopics of the topic $Topi_{ij}$ to a student, the student has to give test on question set Q_{ij} which is set on the subtopics of $Topi_{ij}$. Q_{ij} comprises of v number of questions. Each question Q_{ijz} , $1 \leq z \leq v$, in Q_{ij} can be set on one or more subtopics of $Topi_{ij}$.

We use a $v \times p$ matrix $MQSutopi$ showing the mapping between v questions in Q_{ij} and p subtopics.

$MQSutopi [r] [s] = 1$, if Q_{ijr} is set on $Sutopi_{ijs}$,

$MQSutopi [r] [s] = 0$, otherwise, for $1 \leq r \leq v$ and $1 \leq s \leq p$.

$MESutopi [r] [s] = 1$, if $MQSutopi[r][s]=1$ and the student has given correct answer to question Q_{ijr} , set on subtopic $Sutopi_{ijs}$.

$MESutopi [r] [s] = 0$, otherwise, for $1 \leq r \leq v$ and $1 \leq s \leq p$.
 $CASutopi[t] =$ Total number of 1's present in the t^{th} column of matrix $MESutopi$.

We maintain an array $CASutopi$ (decision variable) of size p such that for $1 \leq t \leq p$. It may be noted that total number of 1's present in the t^{th} column of matrix $MESutopi$ signifies how many questions on subtopic $Sutopi_{ijt}$ are correctly answered by a student. If the value in $CASutopi[t]$ is less than threshold Th_{ijt} , then we find a tutorial gap in subtopic $Sutopi_{ijt}$ for the student and assign tutorials to the student on subtopic $Sutopi_{ijt}$.

The threshold plays very important role in this method. Threshold normally decided according to two aspects: (1) academic level (e.g. age, class etc.), (2) academic standard (e.g. rank of the institutes in global or national scenarios). If same content and test questions are used for this purpose, the threshold could vary with respect to academic levels. For example, school educators will use low threshold compared to college level institutes or UG level will set low threshold compared to PG courses.

On the other hand, if the same system is used in different institutes, they should have the liberty to set the threshold according the quality of education they are expecting. OBE also advocates continuously improving the quality of the outcome and hence they need to increase the threshold gradually according to educational objectives, mission and vision of the institutes.

4. IMPLEMENTATION

The proposed technique is implemented using a web based system developed using PHP-MySQL technology using WAMP server at the back and functioning like an small ITS. Such technology has been chosen because of their simplistic nature and easiness from developer's perspective. Since the focus is to implement the tutorial gap identification scheme, the content delivery parts of the proposed system is not discussed and presented here. Following figure 1 presents the simple interface of implementation of test students need to undergo inside the system as an evidence of conducting test and collecting responses using an automated system.

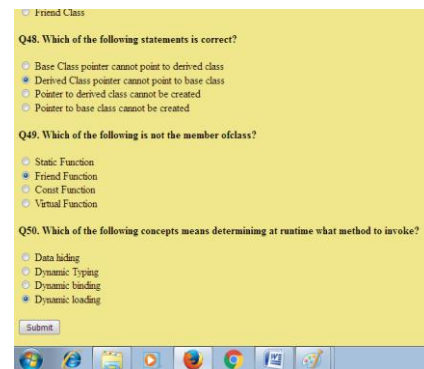

Figure 1. Evidence of conducting MCQ Test

The following figure 2 presents the interface of subtopic wise analysis report according to the proposed scheme.

The following figure 3 presents the interface of the proposed system providing discovered instructions to the students about their tutorial requirements so that they can go through the required tutorials and offering the educational outcome as expected from the system as per regulatory framework.

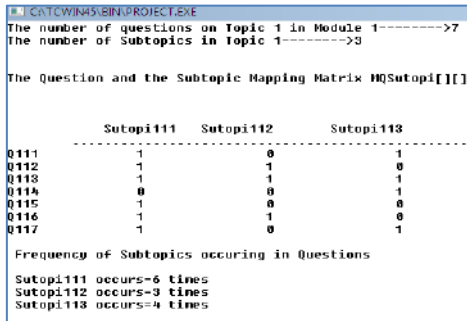

Figure 2. Subtopic wise analysis of responses to MCQ questions

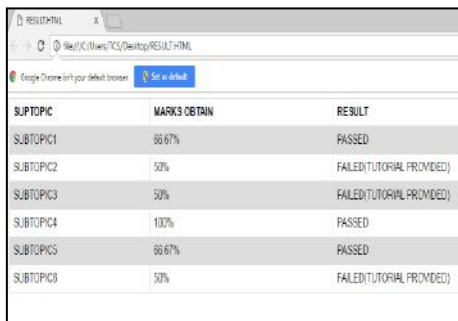

Figure 3. Recommendation report based on analysis using proposed method

The prototype of the proposed system (integrated with the identification scheme), can be improved to work more fruitfully having many features of ITS.

5. RESULTS AND DISCUSSIONS

The developed web based tool was examined through some testing procedure. Though the proposed technique can be used for tutorial gap identification irrespective of any level of education having computer literate target students, the testing was focused on 2nd and 3rd year Computer Science and Engineering students. First experiment conducted with the 50 students of second year Computer Science and Engineering divided into two groups on the course computer organization. It has been observed that the developed method could identify one or more tutorial gap predefined while designing the content and agreed on the MCQ questions for 75% cases. Second experiment conducted on the same set up on third year student on the course operating system but result shows that in around 80% cases predefined gap has been identified. Result of identification observed to be poor a little for 2nd year due to heterogeneous background on account of lateral entry students' consideration perhaps.

So, we can say that the proposed scheme found efficient at least for engineering education. Further experiment on this regard is yet to be conducted for others educational scenarios. It is also expected that the results may further be improved if

better care is taken while design the instructional materials and questions set. On this view, research may further be extended towards standardization of personalized content and questions which was beyond the scope of this venture.

6. CONCLUSIONS

This paper contributes to the literature by proposing a new technique for curriculum gap identification through tutorial recommendation. This paper also advocates the use of automated ICT based tools for such gap identification. This ICT based tools will be able to overcome the limitations of human tutors having diversified experience and teaching styles. Personalized students' models could be presented having deficiencies pointed there in with the help of the use of ICT tools integrated with the proposed technique. Extended version of this proposed technique can be integrated within an ITS so that learning experience could be made better and convert it as ILE. Not only ITS implementation, but conceptualization of the method can improve the teaching performance and hence students' performance with respect to OBE. More use of machine learning and pattern recognition techniques can uplift the work to a level where professional success of educators will not be far away.

REFERENCES

- [1] Handbook of training evaluation and measurement methods. (2016). Routledge, Oxon, UK.
- [2] Spady W. (1994). Choosing outcomes of significance, *Educational Leadership*, Vol. 5, No. 1, pp. 18–23.
- [3] Spady W., Marshall K. (1994). Beyond traditional outcome-based education, *Educational Leadership*, Vol. 49, No. 2, pp. 67–72.
- [4] Zaman W., Das A., Basu P.N. (2007). A survey on computer based training---an Indian perspective, *Proc. of Int. Conf. on Emerging Trends in Electrical Engineering*, Dept. of EE, Jadavpur University at Science City, Kolkata, India, pp. 492-497.
- [5] Bag R., Das A. (2010). Developing an intelligent tutoring system following Bayesian approach, *Int. J. of Advanced Engineering & Applications*, Vol. 2, pp. 114-119.
- [6] Mitra M., Das A. (2015). A fuzzy logic approach to assess web learner's joint skills, *Int. J. of Modern Education and Computer Science*, Vol. 9, pp. 14-21. DOI: [10.5815/ijmecs.09.02](https://doi.org/10.5815/ijmecs.09.02)
- [7] Bose D., Das A. (2015). Using fuzzy trapezoidal rule for web learner's competence assessment, *Int. J. of Electronics and Communication Technology*, Vol. 6, No. 1, pp. 169-173.
- [8] Banerjee S., Bag R., Das A. (2016). Design and development of a web based teaching performance assessment tool with student feedback and fuzzy logic, *3rd Int. Conf. on Foundations and Frontiers in Computer, Communication and Electrical Engineering (C2E2-2016)*, 15th-16th January, 2016 at SKFGI, Mankundu, Hooghly, WB, India, pp. 475-479, DOI: [10.1201/b20012-93](https://doi.org/10.1201/b20012-93)
- [9] Mitra M., Das A. (2013). Applying a fuzzy technique for web-based learner's performance evaluation, *Proc. of National Conf. on Control, Communication & Device*

- Electronics (N3CD-2013)*, JIS Engineering College, Kalyani, WB, India, pp. 125-131.
- [10] Sison R., Shimura M. (1998). Student modelling and machine learning, *Int. J. of Artificial Intelligence in Education*, Vol. 9, pp. 128-158.
- [11] Koedinger K.R., Nathan M.J. (2004). The real story behind story problems: effects of representations on quantitative reasoning, *The Journal of Learning Sciences*, Vol. 13, No. 2, pp. 129-164.
- [12] Koedinger K.R., McLaughlin E.A. (2010). Seeing language learning inside the math: cognitive analysis yields transfer, *In Proc. of the 32nd Annual Conf. of the Cognitive Science Society*, Austin, TX, pp. 471-476.
- [13] Cen H., Koedinger K., Junker B. (2006). Learning factors analysis-a general method for cognitive model evaluation and improvement, *In Proc. of the 8th Int. Conf. on Intelligent Tutoring Systems*, pp. 164-175.
- [14] Li N., Cohen W., Koedinger K.R., Matsuda N. (2011). A machine learning approach for automatic student model discovery, *In Educational Data Mining*.

An FPGA Based Block Cipher through Recursive Positional Substitution on Prime-Nonprime of Cluster (RPSPNC)

Rajdeep Chakraborty¹, Runa Seth¹ and J.K. Mandal²

¹Department of Computer Science and Engineering, Netaji Subhash Engineering College, Garia, Kolkata-154, West Bengal, INDIA, rajdeep_chak@rediffmail.com, runaseth2006@gmail.com

²Department of Computer Science and Engineering, FETM, University of Kalyani, Nodia, West Bengal, INDIA, jkmandal@rediffmail.com

ABSTRACT

The technique considers the plaintext as a stream of finite number of bits N , and is divided into a finite number of blocks, each also containing a finite number of bits n , where $1 \leq n \leq N$. Here orientation of the position of bits within a block is performed through a generating function. If the operation is repeated using the same generating function, the original block is regenerated after a finite number of iterations forming a cycle. For a particular length of block, the block itself is regenerated after a finite number of such iterations. Any of the intermediate blocks within this cycle is considered to be the encrypted block. To decrypt the encrypted block from the ciphertext, the same process is to be followed but the process using same generating function is to iterated for different number of times. To achieve the security of a satisfactory level, it is suggested that various blocks or blocks should be of different sizes. The technique does not incur any storage overhead. The technique generates a large key space, so that the chance of breaking the ciphertext is difficult by any technique of cryptanalysis. The implementation on practical scenario is well proven with positive outcome.

Keywords: FPGA, Symmetric Block Cipher, Prime Numbers, VHDL, Synthesis

I. INTRODUCTION

Lack of security may exist when a volume of data is transferred from its source to the destination if no measure is taken for its security. For one reason or the other, most of the data being transmitted must be kept secret from others [3,6]. A very important reason to encode data or messages is to keep them secret. From e-mail to cellular communication, from secured web access to digital cash, cryptography [3,6] is an essential part of today's information systems. It can prevent fraud in electronic commerce and assure the validity of financial transactions. It can prove one's identity and protect one's anonymity. These electronic commerce schemes may fall fraud through forgery, misrepresentation, denial of service and cheating [3,6] if we do not add security to these systems. In fact, computerization makes the risks even greater by allowing attacks that are impossible in non-automated systems. Only strong cryptography can protect against these attacks.

The Section II of this paper deals with the proposed scheme. A concept of key-generation is given in Section III. Section IV describes the implementation through an

FPGA-based system. Results and comparisons are illustrated in Section V. Conclusions are drawn in Section VI.

II. THE TECHNIQUE RPSPNC

The generating function $t=g(s)$, [6] where 's' is the source stream and 't' is the target stream/intermediate block, the generation function orients the positions of different bits, is applied on a block of size n to generate an intermediate block of the same size. The target stream/intermediate block t is generated by the following rules:

1. A bit in the position i ($1 \leq i \leq n-2$) in the block s becomes the bit in the position $(n-i)$ in the block t , if $(n-i)$ is a non-prime integer [1,2].
2. A bit in the position i ($1 \leq i \leq (n-2)$) in the block s becomes the bit in the position j ($1 \leq j \leq (n-i-1)$) in the block t , where j is the precedent prime integer (if any) of $(n-i)$, if $(n-i)$ is a prime integer [1,2].
3. A bit in the position n in the block s remains in the same position in the block t otherwise.
4. A bit in the position $(n-2)$ in the block s is transferred in the block t to the position unoccupied by any bit after rules 1, 2 and 3 are applied.

The technique is illustrated using a flow diagram given in figure 1.

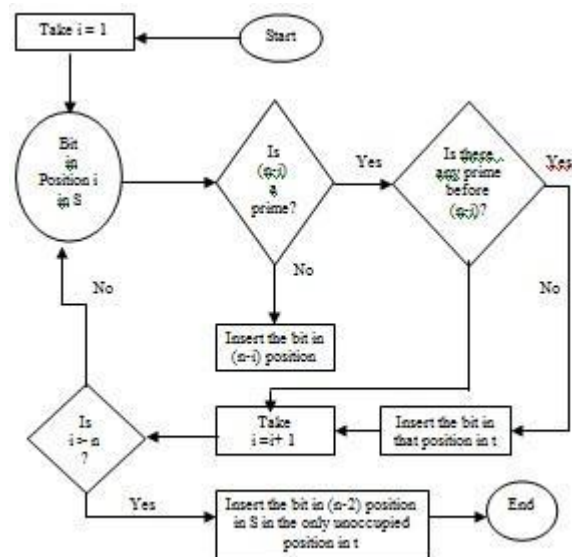

Fig. 1. Overview of RPSPNC

Subsection A. gives the process of encryption, subsection B. gives the decryption process and subsection C. illustrates one example.

A. Encryption

The process of encryption [3,6] is the sub set of the entire set of iterations to form the cycle for a given block. Any intermediate block, t, during the process of forming the cycle may be considered as the encrypted block. Hence if the number of iterations required to form the cycle is ‘i’ for a block of size n, the number of intermediate blocks generated in the cycle is (t), because each iteration generates one block and the final iteration generates the same source block.

B. Decryption

Process of decryption [3,6] is also a sub set of the entire set of work required to form the cycle for the block. The only difference is that one intermediate block of the cycle (the encrypted block) is considered to be the source block in the process of decryption. If the block generated after the tth iteration in the cycle (1 <= t <=(i-1)), ‘i’ being the total number of iterations required to form the cycle, is considered to be the encrypted block, number of iterations required to decrypt the encrypted block is (i-t).

C. Example

Reorientation of bits in a finite length of block can be explained better with an example. Let us consider the block s = 01001011 of size 8 bits.

Source Block							
0	1	0	0	1	0	1	1
1	2	3	4	5	6	7	8
Block After 1 st Iteration							
1	1	0	0	0	1	0	1
1	2	3	4	5	6	7	8
Block After 2 nd Iteration							
0	0	0	0	1	1	1	1
1	2	3	4	5	6	7	8
Block After 3 rd Iteration							
1	1	0	0	0	0	1	1
1	2	3	4	5	6	7	8
Block After 4 th Iteration							
1	0	0	0	1	1	0	1
1	2	3	4	5	6	7	8
Block After 5 th Iteration (Source Block)							
0	1	0	0	1	0	1	1
1	2	3	4	5	6	7	8

Fig. 2. Target block is generated from source block

Table I

Illustration of Mapping (s → t) for Block of Size 8

s	t	Mapping logic from s to t
1	5	Here 8 – 1 = 7, a prime; the precedent prime of 7 is 5
2	6	Here 8 – 2 = 6, a non-prime
3	3	Here 8 – 3 = 5, a prime, the precedent prime of 5 is 3
4	4	Here 8 – 4 = 4, a non-prime
5	2	Here 8 – 5 = 3, a prime, the precedent prime of 3 is 2
6	?	Here 8 – 6 = 2, a prime, there is no precedent prime, allocation suspended
7	1	Here 8 – 7 = 1, a non-prime
8	8	Here 8 being the position of the LSB, no change in position
6	7	One allocation was suspended earlier; since the position 7 is only the unoccupied position so far, that allocation is made there

Figure 1 demonstrates the different intermediate blocks and the target block generated during the cycle.

The Flow diagram to show how positions of the bits of ‘s’ and the different intermediate blocks can be reoriented to complete the cycle is shown in figure 2.

Here since number of iterations (t) [5,6] required to form the cycle is 5, the tth block may be considered as the encrypted block, where ‘t’ ranges from 1 to 4.

How the mapping of source block ‘s’ to a target block ‘t’ is illustrated in table I.

III. THE KEY GENERATION

In the proposed scheme, eight rounds have been considered, each for 2, 4, 8, 16, 32, 64, 128, and 256 block size. Each round is repeated for a finite number of times and the number of iterations will form a part of the encryption-key [2,3,6]. Although the key may be formed in many ways, for the sake of brevity it is proposed to represent the number of iterations in each round by a 16-bit binary string. The binary strings are then concatenated to form a 128-bit key for a particular key. Subsection A. illustrates the key generation process.

Table II

Representation of number of iterations in each round by bits

Round	Block Size	Number of Iterations	
		Decimal	Binary
1.	256	50021	1100001101100101
2.	128	49870	1100001011001110
3.	64	48950	1011111100110110
4.	32	44443	1010110110011011
5.	16	46250	1011010010101010
6.	8	4321	0001000011100001
7.	4	690	0000001010110010
8.	2	72	000000001001000

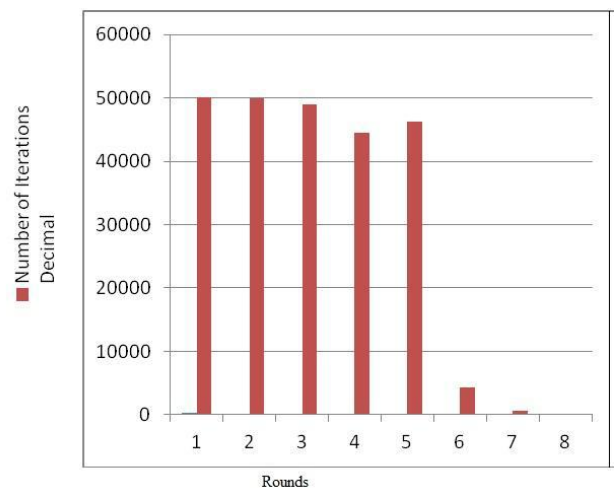

Fig 3. Round v/s iteration

A. EXAMPLE

Consider a particular session [1,3,6] where the source file is encrypted using iterations for block sizes 2, 4, 8, 16, 32, 64, 128, and 256 bits, respectively. Table II shows the corresponding binary value for the number of iterations in each round. Figure 3. shows the graph for the round v/s iteration. When the block size is 2-bit then the process of RSPNC is applied 72 times, for 4-bit block size the process of RSPNC is applied 690 times, similarly when the block size is 256-bit then the process of RSPNC is applied 50021 times. The number of times of iteration is solely decided by the user or sender of the secret message.

These numeric values are converted to equivalent binary strings and these binary strings are concatenated together to form the 128-bit binary string:

```
110000110110010111000010110011101011111001101
1010101101100110111011010010101010000100001110
00010000001010110010000000001001000.
```

This 128-bit binary string will be the key for encryption for a particular session. During decryption, the same key is taken to iterate each round of modulo-subtraction for the specified number of times.

IV. IMPLEMENTATION

This technique has been implemented in C and then feasibility study has been performed. Finally, FPGA [4,6] based implementation has been done in VHDL [5]. In both implementation, the technique takes input from file as a source stream and encryption is performed. The cipher text generated is finally written in another file. The data blocks (8, 16, 32, 64, 128 and 256-bits) from the input file have been stored in array. Then encryption is performed and also stored in array. The reading and writing of data from and in file is based on 8-bit ASCII codes [2,6]. Xilinx ISE 8.1i [4,5,6] software has been used for writing codes in VHDL.

Figure 4 gives the implementation of RSPNC entity and its function. The encryption/decryption entity input bit vector (16-bit), output bit vector (16-bit), key bit vector (8-bit) and EN_DN signal. If EN_DN = 1 then encryption is performed else decryption is performed. During encryption the input bit vector of 16-bits is the plaintext and output 16-bit vector is the ciphertext where as EN_DN value is '1'. During decryption the input bit vector of 16-bits is the ciphertext and the output 16-bit vector is the plaintext where as EN_DN value is '0'. Figure 5 shows the top RTL diagram of RSPNC [4,5,6].

When EN_DN = 1, the 'RSPNC_Encryption' function is called with the parameters, 'varin_bits' which is the plaintext, 'varout_bits' which is the ciphertext, both of these are of 16-bits and third parameter is the 'key_bits' which is the session key of the encryption of 8-bits. When EN_DN = 0, the 'RSPNC_Decryption' function is called with the parameters, 'varin_bits' which is the ciphertext, 'varout_bits' which is the plaintext, both of these are of 16-bits and third parameter is the 'key_bits' which is the session key of the decryption of 8-bits. This code is written in VHDL using behavioral model of coding. The 'RSPNC_VHDL' entity in this

coding has three ports, 'input_bits' of IN type of bit vector of 16-bits, 'output_bits' of OUT type of bit vector of 16-bits, 'key_bits' of IN type of bit vector of 16-bits and 'EN_DN' bit of IN type. 'Behavioral' is the architecture of the entity 'RSPNC_VHDL', this architecture contains a process which is called on the signal 'EN_DN' that is whenever there is a signal in 'EN_DN' this process is called. This process contains two functions, 'RSPNC_Encryption' and 'RSPNC_Decryption'. These two functions are called according to the value of signal bit 'EN_DN' which is already discussed. The implementation here is both functional and files type. These means that the code can be implemented in Xilinx FPGA and the simulation takes the input from a text file and the output is written into another text file. There are various libraries are used, library 'std' and library 'ieee', it is important to note that library 'ieee.std_logic_TEXTIO.all' is used for the implementation of text file reading and writing.

```
library std;
library ieee;
use ieee.std_logic_arith.all;
use work.pack.all;
use std.textio.all;
use ieee.std_logic_TEXTIO.all;
entity RSPNC_VHDL is
Port ( input_bits : in BIT_VECTOR (16 downto 1);
        output_bits : out
        BIT_VECTOR (16 downto 1); key_bits : in
        BIT_VECTOR (8 downto 1);
        EN_DN : in BIT);
end RSPNC_VHDL;
architecture Behavioral of RSPNC_VHDL is
begin
process(EN_DN)
variable varin_bits,varout_bits: bit_vector(16 downto
1);
begin
if (EN_DN='1')then varin_bits:=input_bits;
AA:
RSPNC_Encryption(varin_bits,key_bits,varout_bits);
output_bits<=varout_bits;
else
BB:
RSPNC_Decryption(varin_bits,key_bits,varout_bits);
output_bits<=varout_bits;
end if;
end process;
end Behavioral;
```

Fig 4. RSPNC entity and its function

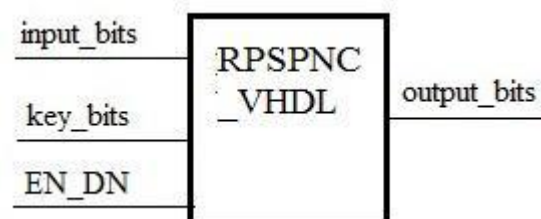

Fig 5. Top level RTL design of RSPNC

V. RESULT AND COMPARISONS

The main emphasis is given on comparisons with RSA. Subsection A gives RTL simulation based results, subsection B gives frequency distribution graph, subsection C gives non-homogeneity test, subsection D deals with time complexity analysis and subsection E chalk out the avalanche ratio test.

A. RTL SIMULATION BASED RESULT

In this section gives some of the results found after implementing RSPNC in VHDL. After synthesizing simulating the code in Xilinx 8.1i [4,5,6]. The main objective is to find an efficient FPGA-based cryptographic technique for implementation in embedded systems.

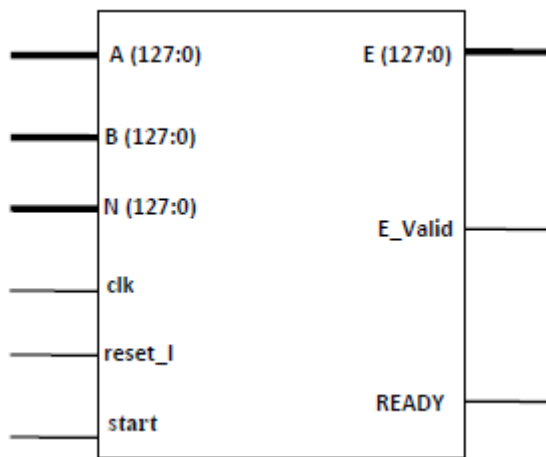

Fig 6. RTL diagram of RSA

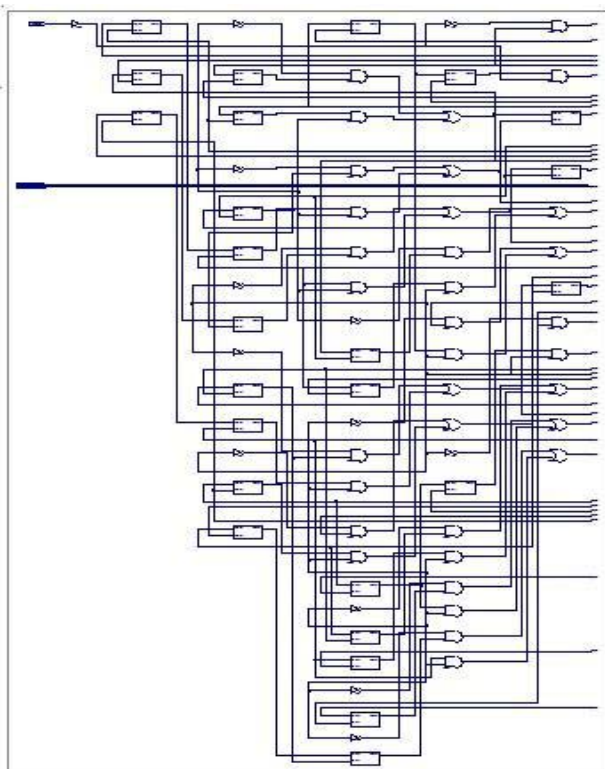

Fig 7. RTL diagram of RSPNC

Table III

HDL synthesis report (Netlist generation of RSA and RSPNC)

Sr No.	Netlist Components	Number	
		RSA	RSPNC
1	ROMs/RAMs	430	110
2	Adders/Subtractions	3	70
3	Registers	420	770
4	Latches	80	80
5	Multiplexers	120	120

Table IV

HDL synthesis report (Timing summary of RSA and RSPNC)

Sr No.	Timing Constraint	Values	
		RSA	RSPNC
1	Speed Grade	-5	-5
2	Minimum period	9.895ns	9.55ns
3	Maximum Frequency	101.06 MHZ	101.06 MHZ
4	Minimum input arrival time before clock	6.697ns	6.55ns
5	Maximum output required time after clock	4.31ns	4.30ns

The design of RSPNC is done using VHDL and implemented in Xilinx Spartan-3E XC3S100E-5VQ100 (package: VQ100, speed grade: -5) FPGA using the ISE 8.1i design tool. Figure 6 shows the RTL of RSA figure 7 shows the RTL of RSPNC.

Table III gives the HDL synthesis report, specifically net list generation [4,5,6] of RSA and RSPNC. RSPNC uses 110 ROMs/RAMs where as RSA uses 430 ROMs/RAMs, RSPNC uses 70 adders/subtractions where RSA uses only 3 adder/subtractions, RSPNC uses 770 registers where as RSA uses 420 registers, both RSPNC and RSA uses 80 latches and 120 multiplexers. Therefore RSPNC is well comparable with RSA.

Table IV gives the HDL synthesis report specifically timing summary [4,5,6] of RSA and RSPNC. The minimum period of RSA is 9.895ns and RSPNC is 9.55ns, minimum input arrival time before clock of RSA is 6.697ns and RSPNC is 6.55 ns and maximum output required time after clock of RSA is 4.31ns and RSPNC is 4.30ns. This implementation has been made on speed grade of -5 and maximum frequency of 101.06 MHZ. Therefore we can say that RSPNC is giving much better result than that of RSA and RSPNC is well comparable with RSA.

B. FREQUENCY DISTRIBUTION GRAPH

The frequency distribution [2,6] is the distribution of the all 256 ASCII characters in the respective files. The degree of cryptanalysis is measures by this method and it is another cryptographic parameter.

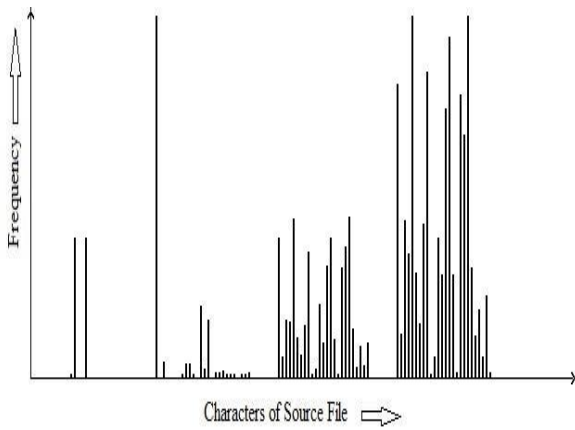

Fig 8. Frequency distribution of source file

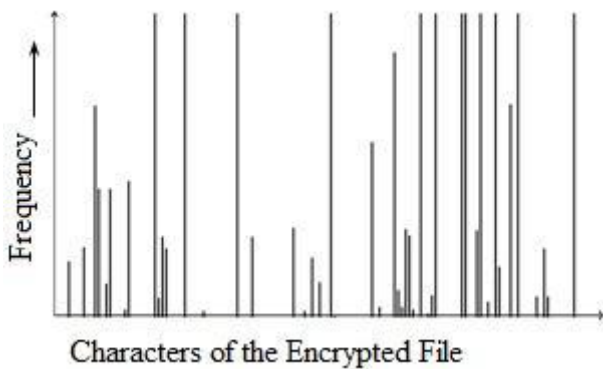

Fig 9. The frequency distribution graph of RSA encrypted file

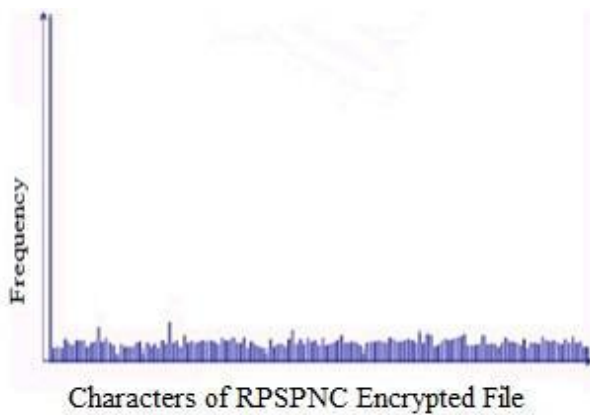

Fig 10. The frequency distribution graph of RPSNPC encrypted file

Figure 8 gives the frequency distribution graph of source file, figure 9 shows the same for RSA encrypted file and figure 10 shows the same for RPSNPC encrypted file. Thus frequency distribution graph of RPSNPC is well comparable with RSA.

C. NON-HOMOGENEITY TEST

Chi-square test [2,6] is performed to find the non-homogeneity [2,6] of RPSNPC with RSA. Ten files of different file typed and different file sizes are taken for this test.

Table V
Chi-Square values of RSA and RPSNPC

Source File	File Size (Bytes)	Chi-Square Values		Degree of freedom	
		RSA	RPSNPC	RSA	RPSNPC
license.txt	17,632	5668	7058	64	254
cs405(ei).txt	25,422	2654	88395	66	254
acread9.txt	35,121	447984	581067	73	255
deutsch.txt	47,829	685963	1840256	77	255
genesis.txt	49,600	3318506	6091523	75	255
pod.txt	69,981	694410	6916935	76	255
mspaint.txt	136,463	2667664	8608307	88	255
cmd.txt	152,028	2216429	9514025	73	245
d3dim.txt	193,189	906300	9930856	10	255
clbcataq.txt	403,901	3896171	9968012	11	255

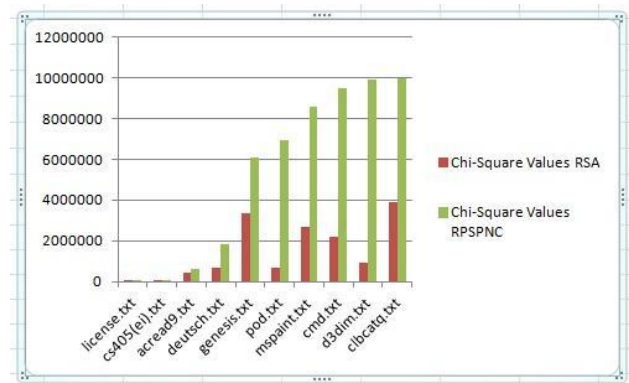

Fig 11. Graphical representation of Chi-Square value of RSA and RPSNPC

Table V shows the Chi-Square values of ten source files of RSA and RPSNPC. It is clearly observed that the extent of non-homogeneity of RPSNPC is quite higher than that of RSA. So, RPSNPC is giving optimal solution in terms of non-homogeneity by using Chi-Square values. Figure 11 shows the result graphically, from it is seen that that for all the ten source files the Chi-Square value of RPSNPC is quite higher than that of RSA. The degree of freedom of this RPSNPC is also quite higher than that of RSA.

D. TIME COMPLEXITY ANALYSIS

Another way to analyze any algorithm is to take the time complexity analysis [2,6]. Here encryption time and decryption time [2,6] have been taken into account.

Table VI
Encryption and decryption time of RSA and RPSNPC

Source File	File Size (Bytes)	Encryption Time		Decryption Time	
		RSA	RPSNPC	RSA	RPSNPC
license.txt	17,632	0.01	0.01	0.28	0.18
cs405(ei).txt	25,422	0.06	0.03	0.30	0.20
acread9.txt	35,121	0.07	0.05	1.67	0.90
deutsch.txt	47,829	0.11	0.10	3.51	2.90
genesis.txt	49,600	0.12	0.11	5.06	2.55
pod.txt	69,981	0.12	0.11	4.34	3.60
mspaint.txt	136,463	0.20	0.21	8.37	4.80
cmd.txt	152,028	0.25	0.21	6.59	6.33
d3dim.txt	193,189	0.28	0.23	10.15	8.68
clbcataq.txt	403,901	0.32	0.25	11.70	10.90

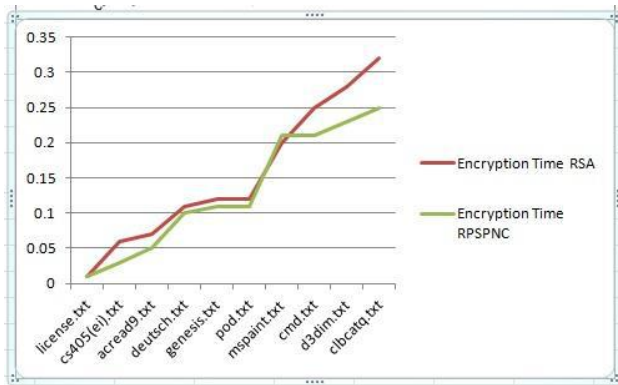

Fig 12. Graphical Representation of Encryption time



Fig 13. Graphical Representation of Decryption time

Table VI gives the tabulation for encryption time and decryption time of both RSA and RPSNPC. Figure 12 gives the graphical representation of encryption time and figure 13 gives the graphical representation of decryption time. The cumulative encryption time of RPSNPC is 1.49 seconds and the cumulative encryption time of RSA is 1.54 seconds. The cumulative decryption time of RPSNPC is 37.5 seconds and cumulative decryption time of RSA is 51.97 seconds. Therefore we can say that RPSNPC is giving much better result than that of RSA.

Table VII
The avalanche ratio of RSA and RPSNPC

Source File	File Size (Bytes)	Avalanche Ratio(in Percentage)	
		RSA	RPSNPC
license.txt	17,632	58.0	88.8
cs405(ei).doc	25,422	60.0	88.0
acread9.txt	35,121	75.0	88.8
deutsch.txt	47,829	78.9	95.5
genesis.txt	49,600	80.9	95.5
pod.exe	69,981	58.0	95.0
mspaint.exe	136,463	58.9	96.5
cmd.exe	152,028	67.0	95.0
d3dim.dll	193,189	67.9	95.0
clbcatq.dll	403,901	68.0	95.5

E. AVALANCHE RATIO TEST

The avalanche ratio test [6] is the extent of which the ciphertext bits flipped when one or more bits of plaintext or key are flipped.

Table VII is giving the avalanche ratio test and here RPSNPC is giving far better result than that of RSA.

VI. CONCLUSION

The technique given here is easily implemented in high level language and also in VHDL. This technique is very easy and it's implemented in FPGA-based systems, the goal of fast execution and strong cryptanalysis requirements are also obtained here. Moreover this technique can be fabricated in chip to be used in embedded systems. The main goal of the author is to develop an efficient FPGA-based crypto hardware and this is achieved through this proposed technique.

REFERENCES

- [1] MH Rais, SM Qasim, "A Novel Implementation of AES-128 using Reduced Residue of Prime Numbers based S-Box", International Journal of Computer Science and Network Security, IJCSNS, Volume 9. Number 9, September 2009, ISSN 1738-7906.
- [2] S Dutta and JK Mandal, "Ensuring Information Security through 123-bit recursive substitution of bits through prime-nonprime detection of sub-stream (RSBP)", Journal of Scientific and Industrial Research, Volume 68, July – 2009, pp 584-591, ISSN 0022-4456.
- [3] William Stallings, "Cryptography and Network Security: Principle and Practice", Second Edition, Pearson Education Asia, Sixth Indian Reprint, 2002, ISBN: 81-7808-605-0.
- [4] Wayne Wolf, "FPGA-Based System Design", First Impression – 2009, Pearson Education, ISBN: 978-81-317-2465-1.
- [5] J. Bhasker, "A VHDL Primer", Thirteen Indian Reprint 2004, Pearson Education, ISBN: 81-7808-016-8.
- [6] Rajdeep Chakraborty, Debajyoti Guha and J. K. Mandal, "A Block Cipher Based Cryptosystem Through Forward Backward Overlapped Modulo Arithmetic Technique (FBOMAT)", published in International Journal of Engineering & Science Journal (IJESR), ISSN 2277 – 2685, accepted & published in Volume 2 – Issue 5 (May 2012) issue, pp-349 – 360, indexed by Index Copernicus, Open J Gate, Ulrichs Web, Google Scholar.
- [7] Dutta, S, Dr. B. C. Roy Engineering College, Durgapur, West Bengal, India, "An Approach Towards Development of Efficient Encryption Techniques", Ph. D.(Science) Thesis, Department of Computer Science & Applications, University of North Bengal, India, 2005.

Design of FPGA Based ECB Cryptosystem: RPPT Embedded with TB

Rajdeep Chakraborty¹, Runa Seth¹ and J.K. Mandal²

¹Department of Computer Sc. & Engg, Netaji Subhash Engineering College, Kolkata-152, West Bengal, India.
E-Mail:- rajdeep_chak@yahoo.co.in, runaseth2006@gmail.com

²Dept. of CSE, University of Kalyani, Kalyani, West Bengal, India. E-mail: jkm.cse@gmail.com

ABSTRACT

Cryptography is the method to implement security in computing systems. One of the methods is to design a cryptosystem, which is hardware/ Application-specific integrated circuit (ASIC) and performs fast encryption and decryption. Field-programmable gate array (FPGA) based cryptosystem is trending in recent research and development. This implementation is embedded approach and moreover electronic code block (ECB) approach is taken for final implementation. In TB, bits of the blocks are rearranged in a specific manner, for 4-bits, 8-bits, 16-bits, 32-bits and 64-bits block sizes. In RPPT, xor operation is performed from MSB to LSB of all the bits of particular blocks. In this paper, the main modification is in the implementation perspective. Novel three layer architecture is proposed where RPPT is embedded with TB, where n-bit block plaintext is first encrypted with TB, the resultant n-bit block is encrypted with RPPT and finally n-bit block is encrypted with TB. Many block cipher mode of operation is available, here ECB is chosen for the encryption and decryption. In TB, modification in orientation of bits has been done from original technique.
Keywords: FPGA-based-design, ECB, Embedded-technique, bit-level-implementation.

A. INTRODUCTION

Cryptosystem [3,4,5,6] is a special type of hardware or application specific IC which carries out fast encryption and decryption. Other advantages of cryptosystem are very low power consumption and low installation area as compared to software system. FPGA based cryptosystem [4,5] have become popular due to their very low production cost.

Cryptosystem can be implemented by two ways, first, symmetric key cryptosystem [1,2,3,6] and second, asymmetric key cryptosystem [1,2,3]. Symmetric key cryptosystem is much faster than that of asymmetric key cryptosystem. In this paper two symmetric key

techniques are used, RPPT [7] and TB [7]. Also RPPT is embedded [1] with TB; finally ECB [3] approach is taken to generate ciphertext [1,2,3,6]. This cryptosystem is successfully simulated in Spartan 3E FPGA [4] and software implementation have been also done for testing. This technique is compared with Rivest - Shamir - Adelman (RSA) algorithm [3] for its feasibility. Section II describes the technique, Section III deals with simulation, Section IV illustrates the results and Section V draws the conclusion.

II. THE TECHNIQUE

In this section the design process is illustrated. RPPT is described in section II.A, TB is described in section II.B, Embedded approach and ECB implementation is described in section II.C.

A. Recursive Pared Parity Technique (RPPT)

In RPPT, a new space efficient, universal encryption technique [1,2,3] have been suggested.

Consider a source sub-stream [1,2,3] (which is in binary representation) $B=(X_k, X_{k-1}, \dots, X_0)$, where X_{k-1} is the MSB and X_0 is the LSB.

Now, the transformation formula, which converts the source sub-stream to the immediate sub-stream are as follows:-

$$O_{k-1} = X_{k-1}$$

$$O_i = X_i \text{ xor } O_{i-1}, \text{ where } 1 \leq i \leq (K-2)$$

B. Transformation of Bits (TB)

The total message can be considered as a blocks of bits with different sizes like 2/4/8/16/32/64/128/256 [1,2,3]. The bit swapping can be applied to each block separately. The principle of bit swapping is discussed in following for different block sizes

Consider a block (X) with two binary bits [4,5] a and b:

$$X = ba$$

$$X1 = ab \quad \text{after 1}^{\text{st}} \text{ Swapping}$$

$$X2 = ba \quad \text{after 2}^{\text{nd}} \text{ Swapping}$$

It takes two swapping to get back the original block.

Consider a block (X) with four binary bits

$$X = dcba$$

$$X1 = cdab \quad \text{after 2 bit swapping on X}$$

$$X2 = abcd \quad \text{after 4 bit swapping on X1}$$

$$X3 = badc \quad \text{after 2 bit swapping on X2}$$

$$X4 = dcba \quad \text{after 4 bit swapping on X3}$$

It takes four swapping to get back the original block.

Consider a block (X) with eight binary bits

$$X = hgfedcba$$

$$X1 = ghfedcab \quad \text{after 2 bit swapping on X}$$

$$X2 = efghabcd \quad \text{after 4 bit swapping on X1}$$

$$X3 = abcdefgh \quad \text{after 8 bit swapping on X2}$$

$$X4 = badcfegh \quad \text{after 2 bit swapping on X 3}$$

$$X5 = dcbaghfe \quad \text{after 4 bit swapping on X 4}$$

$$X6 = ghfedcba \quad \text{after 8 bit swapping on X5}$$

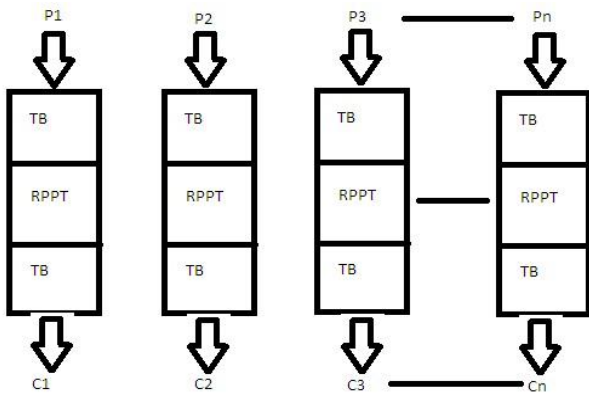

Fig. 1. Schematic diagram of final implementation

It takes six swapping to get back the original block.

In this way the above iterations are followed upto 128 bits. If the block size is 2^n then number of iterations [2] required to get back the original block [2] is $2 \times n$.

C. Implementation

This section describes the final implementation. Fig 1 shows the block diagram.

```

entity Encryption_Decryption is
  Port ( CLK : in STD_LOGIC;
        IN_DATA : in STD_LOGIC_VECTOR (63downto 0);
        OUT_DATA : out STD_LOGIC_VECTOR (63downto 0);
        EN_DN : in STD_LOGIC);
end Encryption_Decryption;
architecture Behavioral of Encryption_Decryption is
file IN_FILE:TEXT
  open READ_MODE is
  "D:\Xilinx14_VHDL_Projects\in.txt";
file OUT_FILE:TEXT
  open WRITE_MODE is
  "D:\Xilinx14_VHDL_Projects\out.txt";
signal BUFFER_STORE: std_logic_vector(63downto 0);
begin
process(CLK, EN_DN)
  variable BUF_IN, BUF_OUT: LINE;
  variable source_std_logic, destination_std_logic;
  buffer_std_logic: std_logic_vector(63downto 0);
begin
  if CLK'EVENT and CLK = '1' then
    if EN_DN = '1' or EN_DN = '0' then
      READLINE(IN_FILE, BUF_IN);
      READ(BUF_IN, source_std_logic);
      BUFFER_STORE <= TB_Three_Rounds(IN_DATA);
      buffer_std_logic :=
      TB_Three_Rounds(source_std_logic);
      BUFFER_STORE <= RPPT_Four_Rounds(BUFFER_STORE);
      buffer_std_logic :=
      RPPT_Four_Rounds(buffer_std_logic);
      OUT_DATA <= TB_Three_Rounds(BUFFER_STORE);
      destination_std_logic := TB_Three_Rounds(buffer_std_logic);
      WRITE(BUF_OUT, destination_std_logic);
      WRITELINE(OUT_FILE, BUF_OUT);
    end if;
  end if;
  file_close(IN_FILE);
  file_close(OUT_FILE);
end process;
end Behavioral;

```

Fig. 2. Top level VHDL module

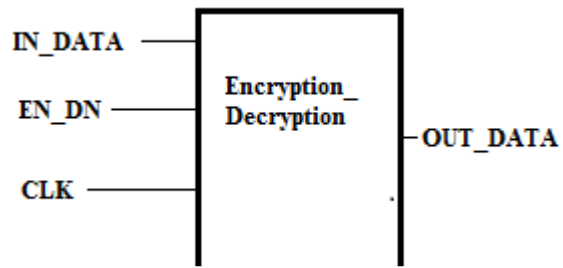

Fig. 3. Top level RTL module

The proposed technique is implemented by ECB mode. ECB is a mode of operation for a block cipher, with the characteristic that each possible block of plaintext has a defined corresponding cipher text value and vice versa. Electronic Code Book is used when a volume of plaintext is separated into several blocks of data, each of which is then encrypted independently of other blocks.

The message is considered as a plaintext [1,2,3] and is divided into n-numbers of blocks P1, P2, P3 Pn. Now, each encryption is consisting of three layer architecture. In the first layer TB is applied on Pk, then RPPT is applied on the resultant, finally TB is again applied on the resultant to generate cipher text block Ck.

This three layer architecture is embedded block cipher [1] and each Pk produces each Ck. Combining all C1, C2, C3 Cn finally ciphertext is generated. This process is also known as Electronic Code Block (ECB) [3] mode of operation.

III. SIMULATION

The proposed technique have been successfully simulated [4,5] for FPGA based system with IEEE VHDL (2002 standard) [5] and programmed in Xilinx ISE 14.2 [4,5].

Fig 2 shows the top level VHDL module [2,4,5]. Implementation is done with modular approach and same program is for RTL simulation [2,4,5] as well as file input and output.

Fig 3 shows the top level RTL module [2,4,5], where inputs are IN_DATA, EN_DN and CLK and OUT_DATA is output. During encryption IN_DATA is the plain text and OUT_DATA is the ciphertext. During decryption IN_DATA is ciphertext and OUT_DATA is plaintext. EN_DN value is 0 for encryption and 1 for decryption. CLK is the clock signal, encryption/decryption [1,2,3] is performed in positive/rising clock signal.

IV. RESULT

The proposed technique, for its feasibility, has been tested with RSA. Three parameters have taken for result and analysis.

TABLE I

	File name	File size	Entropy					
			Proposed Technique			RSA		
			Actual	Max	%	Actual	Max	%
1	Poppy.jpg	18kb	8.00	7.90	98.75	8.00	7.99	99.87
2	07.jpg	81KB	8.00	7.97	99.62	8.00	7.99	99.87
3	sqmapi.dll	131kb	8.00	6.60	82.5	8.00	7.98	99.75
4	Jview.exe	151kb	8.00	4.31	53.87	8.00	7.99	99.87
5	Gender.txt	207kb	4.70	2.54	54.04	8.00	7.99	99.87
6	Pod.exe	245kb	8.00	4.28	53.5	8.00	6.56	82
7	Devices.txt	303kb	4.70	2.92	62.12	8.00	7.99	99.87
8	DTLiteUI.dll	389kb	8.00	5.96	74.5	8.00	7.86	98.25
9	vssapi.dll	421kb	8.00	6.06	75.75	8.00	7.98	99.75
10	Names.txt	473kb	4.70	2.89	61.48	8.00	7.99	99.87

Entropy Test Analysis

Section IV.A discuss entropy test [3], section IV.B deals with the non-homogeneity test [2] and finally section IV.C illustrates the timing analysis [1,2,3].

A. Entropy Test

Truly random data has measurable characteristic called entropy. The term was coined in 1865 to describe a measure of the disorder of a thermodynamically system, and adapted by Shannon in 1948 as a measure of the unpredictability of information content.

Entropy is a function of the distribution. That is, the process used to generate a byte stream is what has entropy, not the byte stream itself. If it is given that the bits 1011, that could have anywhere from 0 to 4 bits of entropy; one have *no way* of knowing that value.

The entropy of a message is just the number of bits of information in the message, that is, the number of bits needed for the shortest possible encoding of the message. Here is the definition of Shannon entropy. Let X be a random variable that takes on the values.

$x_1, x_2, x_3, \dots, x_n$. Then the Shannon entropy is defined as

$$H(X) = -\sum \Pr[x_i] \cdot \log_2(\Pr[x_i])$$

Where $\Pr[x_i]$ represents probability.

With the aid of the information content of the individual messages, the average amount of information which a source with a specified distribution delivers can be calculated. To calculate this mean, the individual messages are weighted with the probabilities of their occurrence.

$$\text{Entropy}(\Pr[x_1], \Pr[x_2], \dots, \Pr[x_r]) := - [\Pr[x_1] * \log(\Pr[x_1]) + \Pr[x_2] * \log(\Pr[x_2]) + \dots + \Pr[x_r] * \log(\Pr[x_r])]$$

Note that the definition is a function of a random variable (i.e., a distribution), *not* a particular value. So, it can be said that lower is the entropy (inversely with probability of occurrence) higher is the randomness.

Table I shows the entropy test result. This test is done by Cryptool software. One input file is encrypted using RSA and then calculated entropy. In the next step the same input file is encrypted by proposed technique and then entropy is calculated from cipher text. It can be observed that entropy of the proposed technique is much lower than that of RSA. So, proposed technique is more random than that of RSA.

B. Non-Homogeneity Test

Non-homogeneity test is carried out using Pearson 's Chi-Square value. The Chi-squared Statistic is a measure of how similar two categorical probability distributions are. If the two distributions are identical, the chi-squared statistic is 0, if the distributions are very different, some higher number will result. The formula for the chi-squared statistic is:

$$X^2 = \sum_{i=1}^n \frac{(O_i - E_i)^2}{E_i}$$

O stands for the Observed frequency. E stands for the Expected frequency. Table II and fig 4 illustrates the result.

The observed frequency is the plaintext or ten source files. The expected frequency is the ciphertext or ten output files. Thus Chi-Square is calculated using above formulae.

Fig 4 is the logarithmic base 10 values of Chi-Square values of proposed technique and RSA. So, it can be seen that Chi-square values of proposed technique is quite higher than RSA for all ten files. It can be concluded proposed technique is more non-homogenous/heterogeneous than RSA. The degree of freedom of proposed technique is also higher than that of RSA.

C. Time Complexity Analysis

Time complexity analysis gives the efficiency of an algorithm means how much time an algorithm takes to generate correct output. Here posterior analysis of algorithm is used which directly depends on system and can measure only after running it on system. Therefore RSA and Proposed algorithm execution time notified on the same system to get the appropriate result. In time complexity analysis both encryption time and decryption time are taken. During analysis same file is taken as input for both the algorithm (RSA and Proposed) and calculate

the difference between end time and start time i.e. execution time of each algorithm. Table III illustrates the result.

TABLE II
Non-Homogeneity Test Analysis

Sr	File name	File size	Proposed Technique		RSA	
			Chi value	Degree of freedom	Chi value	Degree of freedom
1	Poppy.jpg	18kb	932	255	480	200
2	07.jpg	81K B	4196	255	2250	225
3	sqmapi.dll	131kb	453939	255	98760	220
4	Jview.exe	151kb	3577211	255	110750	215
5	Gender.txt	207kb	132754464	84	233805	88
6	Pod.exe	245kb	4223144	255	857800	215
7	Devices.txt	303kb	257540	65	923760	95
8	DTLiteUI.dll	389kb	3943211	255	1054675	225
9	vssapi.dll	421kb	1772858	255	1170567	235
10	Names.txt	473kb	61141140	89	3907850	90

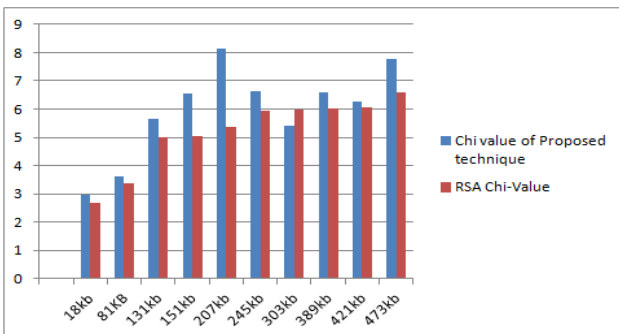

Fig. 4.Top level RTL module

TABLE III
Time Complexity Analysis

File Size (Bytes)	Encryption time (in Seconds)		Decryption time (in seconds)	
	RSA	Proposed Technique	RSA	Proposed Technique
17,632	0.01	0.01	0.28	0.01
25,422	0.03	0.02	0.30	0.02
35,121	0.21	0.02	1.67	0.02
47,829	0.35	0.03	3.51	1.00
49,600	0.40	0.02	5.06	0.95
69,981	0.39	1.00	4.34	0.98
136,463	0.65	1.01	8.37	1.00
152,028	0.61	1.01	6.59	1.01
193,189	0.75	0.99	10.15	1.02
403,901	0.95	1.00	11.70	1.05

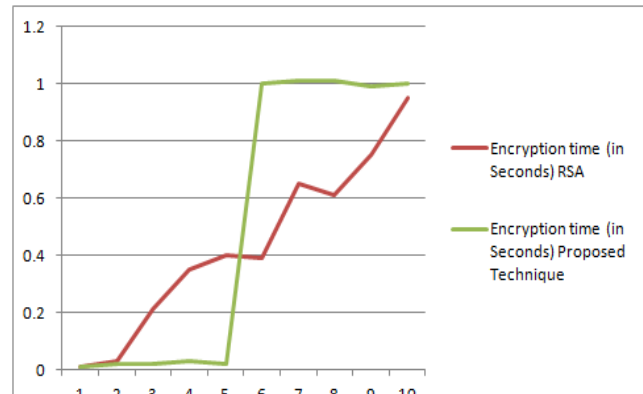

Fig. 5.Encryption time analysis

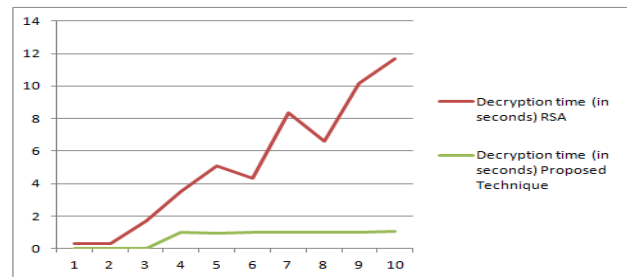

Fig. 6.Decryption time analysis

Fig 5 shows the encryption time analysis and Fig 6 shows the decryption time analysis. Observing both the figures time complexity of the proposed technique is quite less than RSA.

V. CONCLUSION

The proposed technique is successfully designed as a three layer embedded ECB cryptosystem. Proposed technique has been compared for entropy and non-homogeneity with RSA. These two are important cryptographic parameters. In algorithmic perspective the proposed technique has been compared for both encryption time and decryption time with RSA. All the testing results giving optimal result for this proposed technique. This proposed technique has also been successfully simulated for FPGA-based system. Thus with this proposed technique and or with little variation both software and hardware based security systems [3,4,5] can also be developed.

REFERENCES

[1] Miodrag J. Mihaljevic and Hideki Imai, "A Stream Cipher Design Based on Embedding of Random Bits", International Symposium on Information Theory and its Applications, ISITA2008, Auckland, New Zealand, 7-10, December, 2008, ieeexplore.ieee.org

- [2] AvishekDatta, RajdeepChakraborty and J.K. Mandal, "The CRYPTSTER: A Private Key Crypto System", published & presented in 2015 IEEE International Conference on Computer Graphics, Vision and Information Security (IEEE CGVIS 2015) IEEE Conference Record number: #36759, held on November 02-03, 2015, at Bhubaneswar, India, DOI : 10.1109/CGVIS.2015.7449882, pp 06-10.
- [3] Behrouz A. Forouzan, "Cryptography and Network Security", Special Indian Edition 2007, Tata McGraw-Hill, ISBN-13: 978-0-07-066046-5, ISBN-10: 0-07-066046-8.
- [4] Wayne Wolf, "FPGA-Based System Design", First Impression – 2009, Pearson Education, ISBN: 978-81-317-2465-1.
- [5] "A VHDL Primer", Thirteen Indian Reprint 2004, by J. Bhasker, Pearson Education, ISBN: 81-7808-016-8.
- [6] Rajdeep Chakraborty, Avishek Datta and JK Mandal "Secure Encryption Technique (SET): A Private Key Crypto System", published in International Journal of Multidisciplinary in Cryptology and Information Security (IJMCIS) ISSN 2320 –2610, accepted & published in Volume 4, No.1 (January – February 2015) issue, PP 10-13.
- [7] Proceeding of the conference on Intelligent Computing and VLSI, 16-17 Feb, 2001, Kalyani Govt. Engineering College, Kalyani, West Bengal, India.